

DUTY MASTER ALTERNATING CURRENT MOTORS

ENCLOSURE: TOTALLY ENCLOSED
SQUIRREL-CAGE INDUCTION

MOUNTING: FOOT

ACCESSORIES: BEI HS 35 TACH

FRAMES 250T THRU 440T

COOLING: FAN COOLED

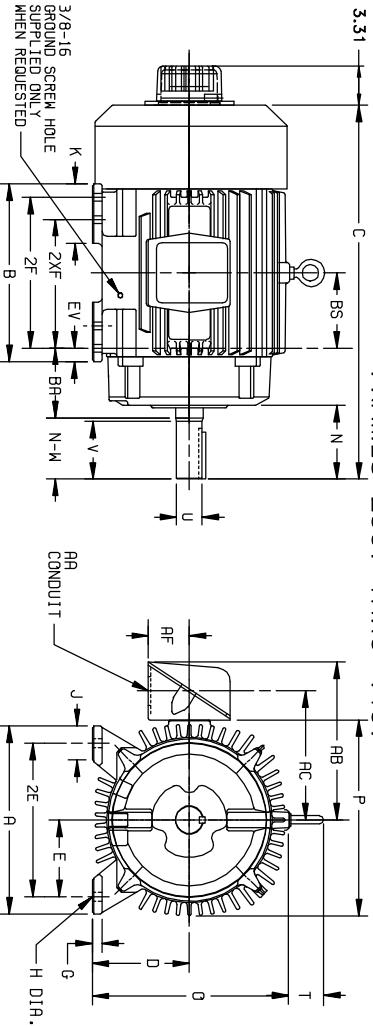

DIMENSIONS ARE IN INCHES

FRAME	A	D(2)	E	G	H	J	K	O	P	STEEL TERMINAL BOX				EV		
										T	AA	AB	AC		AE	BA
254T-256T	12.50	6.25	5.00	.75	.56	2.50	---	13.25	13.25	2.44	1-1/4	10.75	8.75	2.50	4.25	1.00
284T-286TS	13.75	7.00	5.50	.75	.56	2.50	---	14.75	14.88	2.44	1-1/2	12.75	10.00	3.19	4.75	1.00
324T-326TS	15.50	8.00	6.25	.88	.69	2.75	4.50	16.69	17.00	2.44	2	13.19	11.44	4.23	5.23	1.38
364T-365TS	17.00	9.00	7.00	.88	.69	2.75	3.88	18.50	19.50	2.94	3	18.06	14.00	5.38	5.88	1.38
404T-405TS	19.00	10.00	8.00	1.12	.81	3.25	4.62	21.31	22.50	2.94	3	19.31	15.25	5.38	6.62	1.13
444T-445TS	21.00	11.00	9.00	1.12	.81	3.25	5.25	23.38	25.25	3.25	3	23.38	18.12	6.50	7.50	1.25

(1)

FRAME SIZE	C	BS	B	2F	ZXF	(4)	N	SHAFT AND KEY				WEIGHT (LBS. (5))
								N-W(6)	U(3)	V	SQ.	
254T	24.56	5.00	12.00	---	8.25	4.12	4.00	1.625	3.75	.375	2.88	3.05
256T	24.56	5.00	12.00	10.00	---	4.12	4.00	1.625	3.75	.375	2.88	3.15
284T	27.44	5.50	13.00	---	9.50	5.00	4.62	1.875	4.38	.500	3.25	4.35
284TS	26.06	5.50	13.00	---	9.50	3.62	3.25	1.625	3.80	.375	1.88	4.35
286T	27.44	5.50	13.00	11.00	---	5.00	4.62	1.875	4.38	.500	3.25	4.50
286TS	26.06	5.50	13.00	11.00	---	3.62	3.25	1.625	3.00	.375	1.88	4.50
324T	30.44	6.00	14.75	---	10.50	5.62	5.25	2.125	5.00	.500	3.88	5.40
324TS	28.94	6.00	14.75	---	10.50	4.12	3.75	1.875	3.50	.500	2.00	5.40
326T	30.44	6.00	14.75	12.00	---	5.62	5.25	2.125	5.00	.500	3.88	5.80
326TS	28.94	6.00	14.75	12.00	---	4.12	3.75	1.875	3.50	.500	2.00	5.80
364T	33.44	6.12	15.00	---	11.25	6.25	5.88	2.375	5.62	.625	4.25	8.40
364TS	31.31	6.12	15.00	---	11.25	4.12	3.75	1.875	3.50	.500	2.00	7.94
365T	33.44	6.12	15.00	12.25	---	6.25	5.88	2.375	5.62	.625	4.25	8.40
365TS	31.31	6.12	15.00	12.25	---	4.12	3.75	1.875	3.50	.500	2.00	8.34
404T	38.31	6.88	16.00	---	12.25	7.50	7.25	2.875	7.00	.750	5.62	11.20
404TS	35.31	6.88	16.00	---	12.25	4.50	4.25	2.125	4.00	.500	2.75	11.11
405T	38.31	6.88	16.00	13.75	---	7.50	7.25	2.875	7.00	.750	5.62	11.60
405TS	35.31	6.88	16.00	13.75	---	4.50	4.25	2.125	4.00	.500	2.75	11.51
444T	44.62	8.25	19.00	---	14.50	8.94	8.50	3.375	8.25	.875	6.88	15.40
444TS	40.88	8.25	19.00	---	14.50	5.19	4.75	2.375	4.50	.625	3.00	15.24
445T	44.62	8.25	19.00	16.50	---	8.94	8.50	3.375	8.25	.875	6.88	17.50
445TS	40.88	8.25	19.00	16.50	---	5.19	4.75	2.375	4.50	.625	3.00	17.14

(1)

- (1) SPECIAL DIMENSIONS APPLYING TO THIS ORDER ON THIS LINE.
CONDUIT BOX LOCATED ON OPPOSITE SIDE WHEN F-2-W-1, W-4-W-5-W-7, OR C-1 MOUNTING IS SPECIFIED.
- (2) "D" VARIES $\begin{cases} 250T - 320T +.00, -.03 \\ 360T - 440T +.00, -.06 \end{cases}$
IF MOUNTING CLEARANCE DETAILS ARE REQUIRED, CONSULT FACTORY.
- (3) "U" VARIES $\begin{cases} HP TO 1.625 DIA. +.0000, -.0005 \\ 1.625 AND LARGER +.000, -.001. \end{cases}$
MAXIMUM PERMISSIBLE SHAFT RUNOUT WHEN MEASURED AT END OF STD. SHAFT EXTENSION IS .002 T.I.R. UP TO AND INCLUDING 1.625 DIA. AND .003 T.I.R. 1.625 DIA. TO 5 INCH DIA.
- (4) ALL FRAMES HAVE EIGHT MOUNTING HOLES FOR DUAL MOUNTING.
- (5) MOTOR WEIGHTS MAY VARY BY 15% DEPENDING UPON RATING.
- (6) "N-W" VARIES +.00, -.25.

FRAME- _____ TYPE- _____ CERTIFIED FOR- _____
 ORDER- _____ ITEM- _____ HP- _____ RPM- _____ PH- _____ HZ _____ VOLTS _____
 SALES ORDER- _____ APPROVED BY- _____ DATE _____

C/R 380286

10-541-05 10-641-00

002-047119

CUSTOMER IS RESPONSIBLE FOR DETERMINING THAT MOTOR PERFORMANCE IS SUITABLE IN THE APPLICATION.

REV. DESC: REMOVING TITLEBLOCK		
REV. LTR: A	VERSION: 01	TDR: 000000446964
FILE: \RAG\00004\234	REVISED: 15: 33: 32 10/23/2007	BY: CONBPM
MTL: 1		

Baldor • Dodge • Reliance

250T-440T TEFC W/ BEI HS35 TACH