

**SERIES 22H**  
**Line Regen**  
**AC Flux Vector Control**

**Installation & Operating Manual**

# Table of Contents

---

<b>Section 1</b>	
<b>Quick Start Guide</b> .....	1-1
Overview .....	1-1
Quick Start Checklist .....	1-1
Quick Start Procedure .....	1-2
<b>Section 2</b>	
<b>General Information</b> .....	2-1
Overview .....	2-1
Limited Warranty .....	2-2
Safety Notice .....	2-3
<b>Section 3</b>	
<b>Receiving &amp; Installation</b> .....	3-1
Receiving & Inspection .....	3-1
Physical Location .....	3-1
Control Installation .....	3-3
Through the Wall Mounting .....	3-3
Optional Remote Keypad Installation .....	3-4
Electrical Installation .....	3-5
Load Reactors .....	3-5
System Grounding .....	3-5
Protection Devices .....	3-8
Internal Fuses .....	3-8
Wire Size and Protection Devices .....	3-9
Three Phase Input Power Connections .....	3-10
Hardware Changes for Reduced Voltage Input .....	3-12
Motor Connections .....	3-15
M-Contactor .....	3-15
Encoder Installation .....	3-16
Buffered Encoder Output .....	3-16
Home (Orient) Switch Input .....	3-17
Control Board Jumpers .....	3-18
Analog Inputs .....	3-19
Analog Outputs .....	3-20

Continued on next page.

---

Control Circuit Connections .....	3-21
Converting Control Board Connections .....	3-21
Inverter Control Board Connections .....	3-22
Serial Mode .....	3-22
Keypad Mode Connections .....	3-23
Standard Run 3 Wire Mode Connections .....	3-24
15 Speed 2-Wire Mode Connections .....	3-25
3 Speed Analog 2 Wire Operating Mode .....	3-26
3 Speed Analog 3 Wire Operating Mode .....	3-27
Bipolar Speed and Torque Mode Connections .....	3-28
Multiple Parameter Sets .....	3-29
Process Mode Connections .....	3-30
Electronic Pot 2 Wire Operating Mode .....	3-31
Electronic Pot 3 Wire Control Mode .....	3-32
External Trip Input .....	3-33
Opto-Isolated Inputs .....	3-33
Opto-Isolated Outputs .....	3-34
Pre-Operation Checklist .....	3-35
Power-Up Procedure .....	3-36
<b>Section 4</b>	
<b>Programming and Operation .....</b>	<b>4-1</b>
Overview .....	4-1
Baldor Keypad .....	4-2
Display Mode .....	4-3
Adjusting Display Contrast .....	4-3
Display Mode Screens .....	4-3
Display Screens & Diagnostic Information Access .....	4-4
Fault Log Access .....	4-5
Program Mode .....	4-6
Parameter Blocks Access for Programming .....	4-6
Changing Parameter Values when Security Code Not Used .....	4-7
Reset Parameters to Factory Settings .....	4-8
Initialize New Firmware .....	4-9
Parameter Definitions .....	4-10
Converter Control Board Parameters .....	4-10
Inverter Control Board Parameters .....	4-12

Continued on next page.

---

<b>Section 5</b>	
<b>Troubleshooting</b>	5-1
No Keypad Display - Display Contrast Adjustment	5-1
When a Fault is Displayed	5-1
How to Access the Fault Log	5-4
How to Clear the Fault Log	5-5
How to Access Diagnostic Information	5-6
Electrical Noise Considerations	5-15
Special Drive Situations	5-16
Control Enclosures	5-16
Special Motor Considerations	5-16
<b>Section 6</b>	
<b>Manual Tuning the Series 22H Control</b>	6-1
Manually Tuning the Control	6-1
Motor Mag Amps Parameter	6-1
Slip Frequency Parameter	6-1
Current Prop Gain Parameter	6-1
Current Int Gain Parameter	6-2
Speed Prop Gain Parameter	6-2
Speed Int Gain Parameter	6-2
PI Controller	6-3

Continued on next page.

---

<b>Section 7</b>	
<b>Specifications, Ratings &amp; Dimensions</b> .....	7-1
Specifications .....	7-1
Operating Conditions .....	7-1
Keypad Display .....	7-1
Control Specifications .....	7-2
Differential Analog Input .....	7-2
Analog Outputs .....	7-2
Digital Inputs .....	7-3
Digital Outputs .....	7-3
Diagnostic Indications .....	7-3
Series 22H Vector Control Ratings .....	7-4
Terminal Tightening Torque Specifications .....	7-6
Dimensions .....	7-7
Size C+ Control .....	7-7
Size D+ Control .....	7-8
Size D Control .....	7-9
Size E Control .....	7-10
Size E Control – Through–Wall Mounting .....	7-11
Size F Control .....	7-13
Size F Control – Through–Wall Mounting .....	7-14
Size G+ Control .....	7-16
Size H Control .....	7-17
EK Controls - Filter Assembly .....	7-18
EK Controls - Boost Regulators .....	7-19
<b>Appendix A</b> .....	A-1
Converter Section Parameter Values .....	A-1
Power Output Section Parameter Values .....	A-2
<b>Appendix B</b> .....	B-1
Remote Keypad Mounting Template .....	B-2

# Section 1

## Quick Start Guide

---

### Overview

If you are an experienced user of Baldor controls, you are probably already familiar with the keypad programming and keypad operation methods. If so, this quick start guide has been prepared for you. This procedure will help get your system up and running in the keypad mode quickly. This will allow motor and control operation to be verified. This procedure assumes that the control and motor are correctly installed (see Section 3 for procedures) and that you have an understanding of the keypad programming & operation procedures. It is not necessary to wire the terminal strip to operate in the keypad mode, if Level 2 Protection block parameters “External Trip” and “Local Enable INP” are set to off. The quick start procedure is as follows:

1. Read the Safety Notice and Precautions in section 2 of this manual.
2. Mount the control. Refer to Section 3, “Physical Location” procedure.
3. Connect AC power. Refer to Section 3, “AC Input Power Connections”.
4. Connect the motor. Refer to Section 3, “Motor Connections”.
5. Connect the encoder. Refer to Section 3, “Encoder Installation”.

### Quick Start Checklist

Check of electrical items.

**⚠ CAUTION: After completing the installation but before you apply power, be sure to check the following items.**

1. Verify AC line voltage at source matches control rating.
2. Inspect all power connections for accuracy, workmanship and torques as well as compliance to codes.
3. Verify control and motor are grounded to each other and the control is connected to earth ground.
4. Check all signal wiring for accuracy.
5. Be certain all brake coils, contactors and relay coils have noise suppression. This should be an R-C filter for AC coils and reverse polarity diodes for DC coils. MOV type transient suppression is not adequate.

**⚠ WARNING: Make sure that unexpected operation of the motor shaft during start up will not cause injury to personnel or damage to equipment.**

### Check of Motor and Coupling

1. Verify freedom of motion of motor shaft.
2. Verify that motor coupling is tight without backlash.
2. Verify the holding brakes if any, are properly adjusted to fully release and set to the desired torque value.

---

## Quick Start Procedure

### **Initial Conditions**

Be sure the 22H control and motor are installed and wired according to the procedures in Section 3 of this manual.

Become familiar with the keypad programming and keypad operation of the control as described in Section 4 of this manual.

1. Disconnect the load (including coupling or inertia wheels) from the motor shaft if possible.
2. Verify that all enable inputs to J1-8 are open.
3. Turn power on. Be sure no errors are displayed.
4. Set the Level 1 Input block, Operating Mode parameter to "KEYPAD".
5. Set the Level 2 Output Limits block, "OPERATING ZONE" parameter as desired.
6. Enter the following motor data in the Level 2 Motor Data block parameters:  
Motor Voltage (Nameplate, VOLTS)  
Motor Rated Amps (Nameplate, FLA)  
Motor Rated Speed (Nameplate, RPM)  
Motor Rated Frequency (Nameplate, HZ)  
Motor Mag Amps (Nameplate, NLA)  
Encoder Counts
7. At the Level 2 Motor Data, go to CALC Presets and select YES (using the up arrow key). Press ENTER and let the control calculate the preset values for the parameters that are required for control operation.
8. Disconnect the motor from the load (including coupling or inertia wheels). If the load can not be disconnected, refer to Section 6 and manually tune the control. After manual tuning, perform steps 10, 11, 15, 16 and 17.

**⚠ WARNING: The motor shaft will rotate during this procedure. Be certain that unexpected motor shaft movement will not cause injury to personnel or damage to equipment.**

9. At the Level 2 Autotune block, perform the following tests:  
CMD OFFSET TRIM  
CUR LOOP COMP  
STATOR R1  
FLUX CUR SETTING  
FEEDBACK TESTS  
SLIP FREQ TEST
10. Set the Level 2 Output Limits block, "MIN OUTPUT SPEED" parameter.
11. Set the Level 2 Output Limits block, "MAX OUTPUT SPEED" parameter.
12. Remove all power from the control.
13. Couple the motor to its load.
14. Turn power on. Be sure no errors are displayed.
15. Go to Level 2 Autotune block, and perform the SPD CNTRLR CALC test.
16. Run the drive from the keypad using one of the following: the arrow keys for direct speed control, keypad entered speed or the JOG mode.
17. Select and program additional parameters to suit your application.

The control is now ready for use the in keypad mode. If a different operating mode is desired, refer to Section 3 for control connection diagrams and Section 4 Programming and Operation.

## Section 2

### General Information

---

#### Overview

The Baldor Series 22H Line Regen Vector Control provides full motoring and line regeneration to the AC power mains with a near unity power factor. The control uses PWM controlled by IGBT power transistors in both the converter and inverter sections of the control to provide 3 phase power to the motor and Regen power to the line. Flux vector technology (sometimes referred to as Field Oriented Control) is a closed loop control scheme that adjusts the frequency and phase of voltage and current applied to a three phase induction motor. The vector control separates the motor current into its flux and torque producing components. These components are independently adjusted and vectorially added to maintain a 90 degree relationship between them. This produces maximum torque from base speed down to and including zero speed. Above base speed, the flux component is reduced for constant horsepower operation. In addition to the current, the electrical frequency must also be controlled. The frequency of the voltage applied to the motor is calculated from the slip frequency and the mechanical speed of the rotor. This provides instantaneous adjustment of the voltage and current phasing in response to speed and position feedback from an encoder mounted on the motors' shaft.

The Line Regen vector control provides several advantages over non-regenerative drives:

Regenerated energy from the motor is returned to the power source. The control can provide regenerated energy absorption up to its full rating on a continuous basis.

Input current is controlled to be a near unity power factor at rated load.

Line harmonic distortion is reduced.

DC Bus voltage is always controlled. Therefore, line voltage transients do not affect the output voltage to the motor.

The Baldor Series 22H control may be used in many different applications. It may be programmed by the user to operate in different operating zones. It can also be configured to operate in a number of modes depending upon the application requirements and user preference.

It is the responsibility of the user to determine the optimum operating zone and mode to interface the control to the application. These choices are made with the keypad as explained in the programming section of this manual.



---

### **Limited Warranty**

For a period of two (2) years from the date of original purchase, BALDOR will repair or replace without charge controls and accessories which our examination proves to be defective in material or workmanship. This warranty is valid if the unit has not been tampered with by unauthorized persons, misused, abused, or improperly installed and has been used in accordance with the instructions and/or ratings supplied. This warranty is in lieu of any other warranty or guarantee expressed or implied. BALDOR shall not be held responsible for any expense (including installation and removal), inconvenience, or consequential damage, including injury to any person or property caused by items of our manufacture or sale. (Some states do not allow exclusion or limitation of incidental or consequential damages, so the above exclusion may not apply.) In any event, BALDOR's total liability, under all circumstances, shall not exceed the full purchase price of the control. Claims for purchase price refunds, repairs, or replacements must be referred to BALDOR with all pertinent data as to the defect, the date purchased, the task performed by the control, and the problem encountered. No liability is assumed for expendable items such as fuses.

Goods may be returned only with written notification including a BALDOR Return Authorization Number and any return shipments must be prepaid.

---

## **Safety Notice**

This equipment contains voltages that may be as high as 1000 volts! Electrical shock can cause serious or fatal injury. Only qualified personnel should attempt the start-up procedure or troubleshoot this equipment.

This equipment may be connected to other machines that have rotating parts or parts that are driven by this equipment. Improper use can cause serious or fatal injury. Only qualified personnel should attempt the start-up procedure or troubleshoot this equipment.

### **PRECAUTIONS**

- ⚠ WARNING:** Do not touch any circuit board, power device or electrical connection before you first ensure that power has been disconnected and there is no high voltage present from this equipment or other equipment to which it is connected. Electrical shock can cause serious or fatal injury. Only qualified personnel should attempt the start-up procedure or troubleshoot this equipment.
- ⚠ WARNING:** Be sure that you are completely familiar with the safe operation of this equipment. This equipment may be connected to other machines that have rotating parts or parts that are controlled by this equipment. Improper use can cause serious or fatal injury. Only qualified personnel should attempt the start-up procedure or troubleshoot this equipment.
- ⚠ WARNING:** This unit has an automatic restart feature that will start the motor whenever input power is applied and a RUN (FWD or REV) command is issued. If an automatic restart of the motor could cause injury to personnel, the automatic restart feature should be disabled by changing the Level 2 Miscellaneous block, Restart Auto/Man parameter to Manual.
- ⚠ WARNING:** Be sure the system is properly grounded before applying power. Do not apply AC power before you ensure that all grounding instructions have been followed. Electrical shock can cause serious or fatal injury.
- ⚠ WARNING:** Do not remove cover for at least five (5) minutes after AC power is disconnected to allow capacitors to discharge. Dangerous voltages are present inside the equipment. Electrical shock can cause serious or fatal injury.
- ⚠ WARNING:** Improper operation of control may cause violent motion of the motor shaft and driven equipment. Be certain that unexpected motor shaft movement will not cause injury to personnel or damage to equipment. Certain failure modes of the control can produce peak torque of several times the rated motor torque.
- ⚠ WARNING:** Motor circuit may have high voltage present whenever AC power is applied, even when motor is not rotating. Electrical shock can cause serious or fatal injury.
- ⚠ WARNING:** The motor shaft will rotate during the autotune procedure. Be certain that unexpected motor shaft movement will not cause injury to personnel or damage to equipment.

Continued on next page

---

**⚠ Caution:** Suitable for use on a circuit capable of delivering not more than the RMS symmetrical short circuit amperes listed here at rated voltage.

<u>Horsepower</u>	<u>RMS Symmetrical Amperes</u>
1-50	5,000
51-200	10,000
201-400	18,000
401-600	30,000
601-900	42,000

**⚠ Caution:** Disconnect motor leads (T1, T2 and T3) from control before you perform a “Megger” test on the motor. Failure to disconnect motor from the control will result in extensive damage to the control. The control is tested at the factory for high voltage / leakage resistance as part of Underwriter Laboratory requirements.

**⚠ Caution:** Do not supply any power to the External Trip (motor thermostat) leads at J1-16 and 17. Power on these leads can damage the control. Use a dry contact type that requires no external power to operate.

**⚠ Caution:** Do not connect AC power to the Motor terminals T1, T2 and T3. Connecting AC power to these terminals may result in damage to the control.

**⚠ Caution:** Baldor recommends not using “Grounded Leg Delta” transformer power leads that may create ground loops and degrade system performance. Instead, we recommend using a four wire Wye.

**⚠ Caution:** Do not use power factor correction capacitors at the input power lines to the 22H Line Regen control. Installing power factor correction capacitors may damage the control.

## Section 3

### Receiving & Installation

---

#### Receiving & Inspection

The Series 22H Vector Control is thoroughly tested at the factory and carefully packaged for shipment. When you receive your control, there are several things you should do immediately.

1. Observe the condition of the shipping container and report any damage immediately to the commercial carrier that delivered your control.
2. Verify that the part number of the control you received is the same as the part number listed on your purchase order.
3. If the control is to be stored for several weeks before use, be sure that it is stored in a location that conforms to published storage specifications. (Refer to Section 7 of this manual).

#### Physical Location

The location of the 22H is important. It should be installed in an area that is protected from direct sunlight, corrosives, harmful gases or liquids, dust, metallic particles, and vibration. Exposure to these elements can reduce the operating life and degrade performance of the control.

Several other factors should be carefully evaluated when selecting a location for installation:

1. For effective cooling and maintenance, the control should be mounted vertically on a flat, smooth, non-flammable vertical surface. Size G+ are floor standing NEMA 1 enclosures.
2. At least two inches clearance must be provided on all sides for air flow.
3. Front access must be provided to allow the control cover to be opened or removed for service and to allow viewing of the Keypad Display. (The keypad may optionally be remote mounted up to 100 feet from the control.)  
Controls installed in a floor mounted enclosure must be positioned with clearance to open the enclosure door. This clearance will also provide sufficient air space for cooling.
4. **Altitude derating.** Up to 3300 feet (1000 meters) no derating required. Above 3300 ft, derate the continuous and peak output current by 2% for each 1000 ft.
5. **Temperature derating.** Up to 40°C no derating required. Above 40°C, derate the continuous and peak output current by 2% per °C. Maximum ambient is 55°C.
6. **50Hz Operation derating.** For operation on 50Hz input power, derate the continuous and peak output current by 15%.
7. **Shock Mounting.** The control is designed to withstand 0.5G at 10 to 60 Hz shock during normal operation.

#### **Shock Mounting**

If the control will be subjected to levels of shock greater than 1G or vibration greater than 0.5G at 10 to 60Hz, the control should be shock mounted. Excessive vibration within the control could cause internal connections to loosen and cause component failure or electrical shock hazard.

Table 3-1 lists the Watts Loss ratings for Series 22H controls.

**Table 3-1 Series 22H Watts Loss Ratings.**

CONTROL			STD PWM CONV & INV Losses	QUIET PWM CONV & INV Losses	CONTROL FIXED Losses	BOOST REG Loss At Full Load	Line Reactor Loss At Full Load		STD PWM Total Losses	QUIET PWM Total Losses
MODEL No.	SIZE	INPUT VAC	(Watts)	(Watts)	(Watts)	(Watts)	Cat. No.	(Watts)	(Watts)	(Watts)
ZD22H210-EL	C+	230	268	315	102	80	LRAC03501	49	499	546
ZD22H215-EL	C+	230	397	311	102	109	LRAC04501	54	662	576
ZD22H220-EL	C+	230	527	458	102	136	LRAC05501	64	829	760
ZD22H225-EL	C+	230	690	611	102	137	LRAC08001	82	1011	932
ZD22H230-EL	D+	230	571	768	170	164	LRAC08001	82	987	1184
ZD22H240-EL	D+	230	1095	942	170	187	LRAC10001	94	1546	1393
ZD22H250-EL	D+	230	1437	1286	170	225	LRAC13001	108	1940	1789
ZD22H410-EL	C+	460	240	326	102	80	LRAC01802	43	465	551
ZD22H415-EL	C+	460	336	259	102	86	LRAC02502	52	576	499
ZD22H420-EL	C+	460	432	379	102	110	LRAC03502	54	698	645
ZD22H425-EL	D+	460	544	504	102	134	LRAC03502	54	834	794
ZD22H430-EL	D+	460	640	740	170	158	LRAC04502	62	1030	1130
ZD22H440-EL	D+	460	880	738	170	228	LRAC05502	67	1345	1203
ZD22H450-EL	D+	460	1040	1023	170	217	LRAC08002	86	1513	1496
ZD22H460-EK	D+	460	1280	1236	100	299	LRAC08002	86	1765	1721
ZD22H475-EK	E	460	2400	2322	153	395	LRAC10002	84	3032	2954
ZD22H4100-EK	E	460	3000	2928	153	420	LRAC13002	180	3753	3681
ZD22H4150-EK	F	460	3610	CONTROL RATINGS NOT AVAILABLE	191	750	LRAC20002	168	4719	CONTROL RATINGS NOT AVAILABLE
ZD22H4200-EK	F	460	4750		191	850	LRAC25002	231	6022	
ZD22H4250-EL	G+	460	6200		1000	900	LRAC32002	264	8364	
ZD22H4300-EL	G+	460	8140		1000	1620	LRAC40002	333	11093	
ZD22H4450-EL	G+	460	8400		1000	1650	LRAC50002	340	11390	
ZD22H4400-EL	G+	460	10560		1000	1750	LRAC50002	340	13650	
ZD22H4450-EL	G+	460	11880		1000	1850	LRAC60002	414	15144	

---

## **Control Installation**

The control must be securely fastened to the mounting surface. Use the four (4) mounting holes to fasten the control to the mounting surface or enclosure.

**Through the Wall Mounting** Control sizes E and F are designed for panel or through the wall installation. To mount a control through the wall, an optional Through the Wall mounting kit must be purchased. These kits are:

<b><u>Kit No.</u></b>	<b><u>Description</u></b>
V0083991	Size E control Through the Wall mounting kit.
V0084001	Size F control Through the Wall mounting kit.

### **Procedure:**

1. Refer to Section 7 of this manual for drawings and dimensions of the Through the Wall mounting kits. Use the information contained in these drawings to layout the appropriate size hole on your enclosure and wall.
2. Cut the holes in your enclosure and wall.
3. Locate and drill holes for mounting hardware as shown in the drawings.
4. Cut foam tape and apply to perimeter of opening as shown.
5. Secure the four (4) brackets to the exterior of the panel with the hardware provided.
6. Secure the control to the panel using the hardware provided.

---

**Optional Remote Keypad Installation** The keypad may be remotely mounted using the optional Baldor keypad extension cable. The keypad assembly (white - DC00005A-01; grey - DC00005A-02) comes complete with the screws and gasket required to mount it to an enclosure. When the keypad is properly mounted to a NEMA Type 4X indoor enclosure, it retains the Type 4X indoor rating.

**Tools Required:**

- Center punch, tap handle, screwdrivers (Phillips and straight) and crescent wrench.
- 8-32 tap and #29 drill bit (for tapped mounting holes) or #19 drill (for clearance mounting holes).
- 1-1/4" standard knockout punch (1-11/16" nominal diameter).
- RTV sealant.
- (4) 8-32 nuts and lock washers.
- Extended 8-32 screws (socket fillister) are required if the mounting surface is thicker than 12 gauge and is not tapped (clearance mounting holes).
- Remote keypad mounting template. A tear out copy is provided at the end of this manual for your convenience.

**Mounting Instructions: For tapped mounting holes**

1. Locate a flat 4" wide x 5.5" minimum high mounting surface. Material should be sufficient thickness (14 gauge minimum).
2. Place the template on the mounting surface or mark the holes as shown.
3. Accurately center punch the 4 mounting holes (marked A) and the large knockout (marked B).
4. Drill four #29 mounting holes (A). Thread each hole using an 8-32 tap.
5. Locate the 1-1/4" knockout center (B) and punch using the manufacturers instructions.
6. Debur knockout and mounting holes making sure the panel stays clean and flat.
7. Apply RTV to the 4 holes marked (A).
8. Assemble the keypad to the panel. Use 8-32 screws, nuts and lock washers.
9. From the inside of the panel, apply RTV over each of the four mounting screws and nuts. Cover a 3/4" area around each screw while making sure to completely encapsulate the nut and washer.

**Mounting Instructions: For clearance mounting holes**

1. Locate a flat 4" wide x 5.5" minimum high mounting surface. Material should be sufficient thickness (14 gauge minimum).
2. Place the template on the mounting surface or mark the holes as shown on the template.
3. Accurately center punch the 4 mounting holes (marked A) and the large knockout (marked B).
4. Drill four #19 clearance holes (A).
5. Locate the 1-1/4" knockout center (B) and punch using the manufacturers instructions.
6. Debur knockout and mounting holes making sure the panel stays clean and flat.
7. Apply RTV to the 4 holes marked (A).
8. Assemble the keypad to the panel. Use 8-32 screws, nuts and lock washers.
9. From the inside of the panel, apply RTV over each of the four mounting screws and nuts. Cover a 3/4" area around each screw while making sure to completely encapsulate the nut and washer.

## Electrical Installation

Interconnection wiring is required between the motor control, AC power source, motor, host control and any operator interface stations. Use only UL (cUL) listed closed loop connectors that are of appropriate size for wire gauge being used. Connectors are to be installed using crimp tool specified by the manufacturer of the connector. Only Class 1 wiring should be used.

Baldor Series 22H controls feature UL approved adjustable motor overload protection suitable for motors rated at no less than 50% of the output rating of the control. Other governing agencies such as NEC may require separate over-current protection. The installer of this equipment is responsible for complying with the National Electric Code and any applicable local codes which govern such practices as wiring protection, grounding, disconnects and other current protection.

## Load Reactors

Line reactors may be used at the control output to the motor. When used this way, they are called Load Reactors. Load reactors serve several functions that include:

- Protect the control from a short circuit at the motor.
- Limit the rate of rise of motor surge currents.
- Slowing the rate of change of power the control delivers to the motor.

Load reactors should be installed as close to the control as possible. Select the load reactor that matches the full load amperes (FLA) stated on the nameplate of the motor you are using.

## System Grounding

Baldor Controls are designed to be powered from standard three phase lines that are electrically symmetrical with respect to ground. System grounding is an important step in the overall installation to prevent problems. The recommended grounding method is shown in Figures 3-1 and 3-2.

**Figure 3-1 Recommended System Grounding – EL**

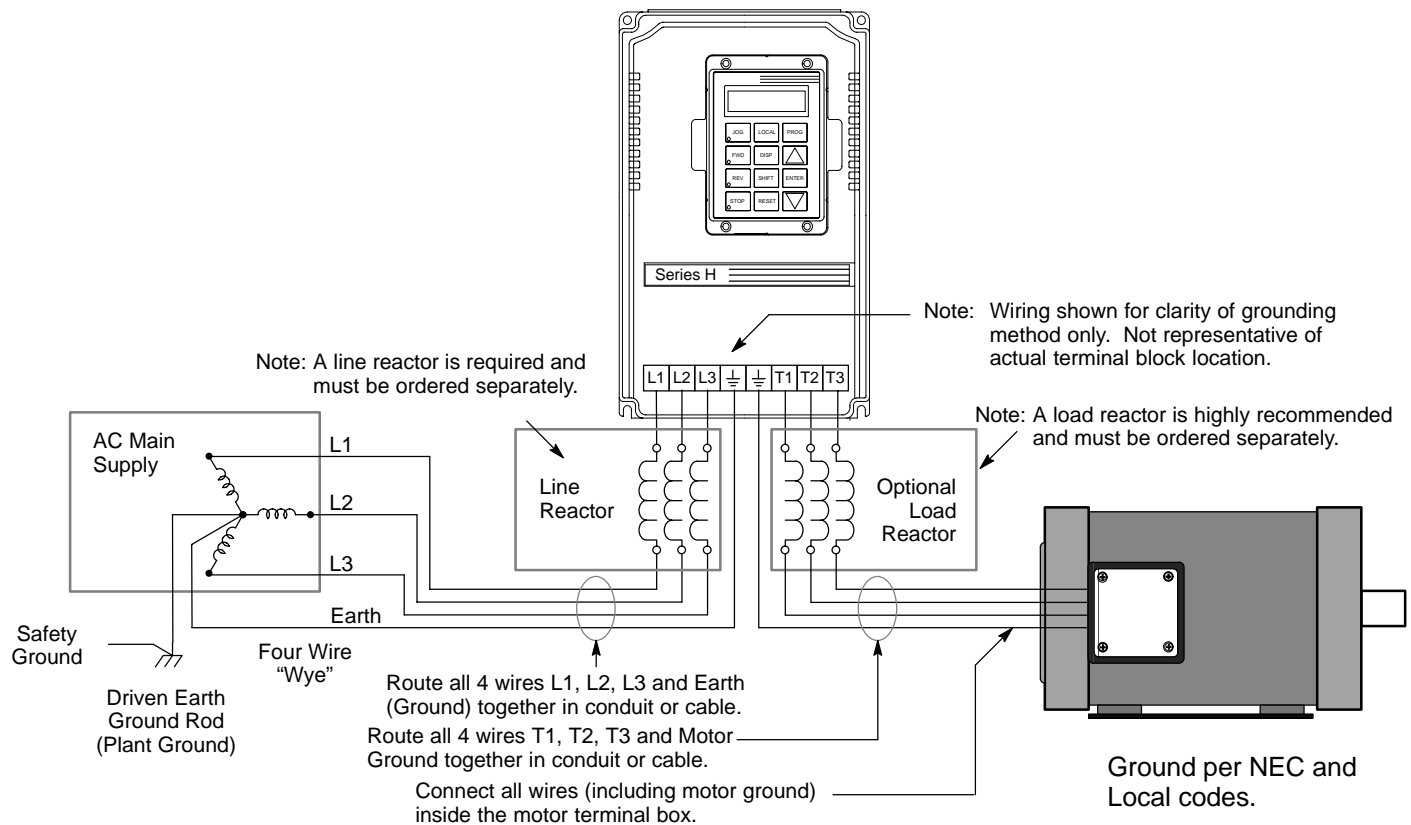



**Figure 3-2 Recommended System Grounding – EK**

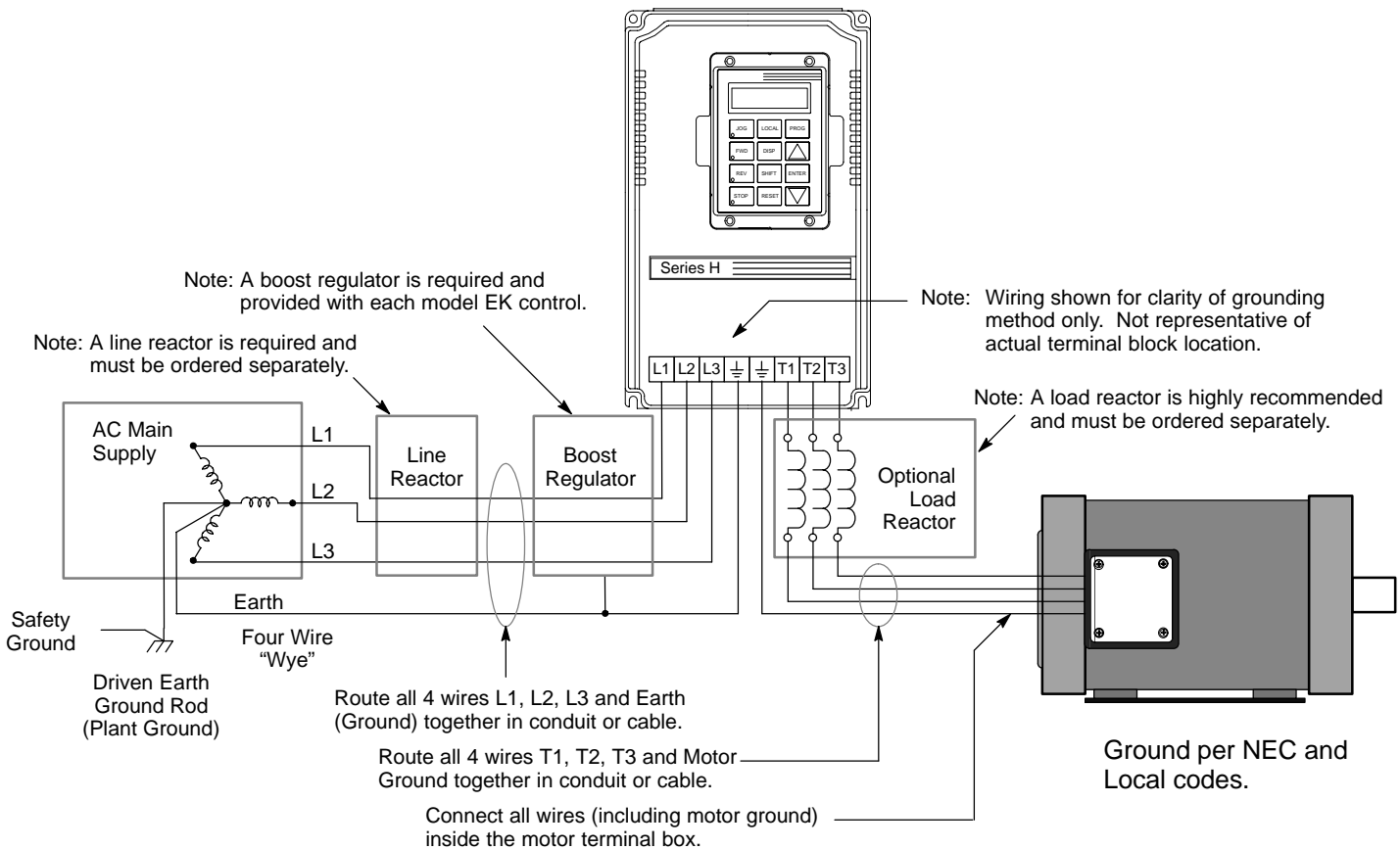

**Ungrounded Distribution System**

With an ungrounded power distribution system it is possible to have a continuous current path to ground through the MOV devices. To avoid equipment damage, an Isolation transformer with a grounded secondary is recommended. This provides three phase AC power that is symmetrical with respect ground.

**Input Power Conditioning**

Baldor controls are designed for direct connection to standard three phase lines that are electrically symmetrical with respect to ground. Certain power line conditions must be avoided. An AC line reactor or an isolation transformer may be required for some power conditions.

- Baldor Series H controls require a minimum line impedance of 3%. Refer to "Line Impedance" for additional information.
- If the feeder or branch circuit that provides power to the control has permanently connected power factor correction capacitors, an input AC line reactor or an isolation transformer must be connected between the power factor correction capacitors and the control.
- If the feeder or branch circuit that provides power to the control has power factor correction capacitors that are switched on line and off line, the capacitors must not be switched while the control is connected to the AC power line. If the capacitors are switched on line while the control is still connected to the AC power line, additional protection is required. TVSS (Transient Voltage Surge Suppressor) of the proper rating must be installed between the AC line reactor or an isolation transformer and the AC input to the control.

### Current Requirements

The input current for each control is given in Table 3-2 and the short circuit requirements are given in Table 3-3. The control may be damaged if input current exceeds ratings.

**Table 3-2 Input Current Requirements**

230VAC		460VAC	
Catalog Numbers	Input Amps	Catalog Numbers	Input Amps
ZD22H210-EL	24	ZD22H410-EL	13
ZD22H215-EL	36	ZD22H415-EK	18
ZD22H220-EL	47	ZD22H420-EL	23
ZD22H225-EL	58	ZD22H425-EL	29
ZD22H230-EL	68	ZD22H430-EL	34
ZD22H240-EL	90	ZD22H440-EL	47
ZD22H250-EL	111	ZD22H450-EL	56
		ZD22H460-EK	68
		ZD22H475-EK	85
		ZD22H4100-EK	107
		ZD22H4150-EK	162
		ZD22H4200-EK	213
		ZD22H4250-EL	264
		ZD22H4300-EL	315
		ZD22H4350-EL	357
		ZD22H4400-EL	408
		ZD22H4450-EL	459

**Table 3-3 Short Circuit Current Ratings**

230VAC		460VAC	
Catalog Numbers	Short Circuit Amps	Catalog Numbers	Short Circuit Amps
ZD22H210-EL	240	ZD22H410-EL	130
ZD22H215-EL	360	ZD22H415-EK	180
ZD22H220-EL	470	ZD22H420-EL	230
ZD22H225-EL	580	ZD22H425-EL	290
ZD22H230-EL	680	ZD22H430-EL	340
ZD22H240-EL	890	ZD22H440-EL	470
ZD22H250-EL	1110	ZD22H450-EL	550
		ZD22H460-EK	680
		ZD22H475-EK	850
		ZD22H4100-EK	1060
		ZD22H4150-EK	1620
		ZD22H4200-EK	2130
		ZD22H4250-EL	2640
		ZD22H4300-EL	3150
		ZD22H4350-EL	3570
		ZD22H4400-EL	4080
		ZD22H4450-EL	4590

## Protection Devices

Be sure a suitable input power protection device is installed. Use the recommended circuit breaker or fuses listed in Table 3-5 and 3-6. Input and output wire size is based on the use of copper conductor wire rated at 75 °C. The table is specified for NEMA B motors.

Circuit Breaker:	3 phase, thermal magnetic. Equal to GE type THQ or TEB for 230 VAC or GE type TED for 460 VAC
Fast Action Fuses:	230 VAC, Buss KTN 460 VAC, Buss KTS to 600A (KTU 601 - 1200A)
Very Fast Action:	230 VAC, Buss JJN 460 VAC, Buss JJS
Time Delay Fuses:	230 VAC, Buss FRN 460 VAC, Buss FRS to 600A (KLU 601 - 1200A)

## Power Disconnect

A power disconnect should be installed between the input power service and the control for a fail safe method to disconnect power. The control will remain in a powered-up condition until all input power is removed from the control and the internal bus voltage is depleted.

## Internal Fuses

**Table 3-4 Internal Fuses**

Control Size	Zero Crossing (Input Interface Board)		Filter Fuses (Filter Board)		Control Transformer		Soft Start Transformer		Fan Control Transformer	
	Rating	Type	Rating	Type	Rating	Type	Rating	Type	Rating	Type
C+	3/10 A 500VAC	FLQ- 3/10 or Equiv.	5A 500VAC	FNQ-5 or Equiv.	3.2A 250VAC	MDA- 3 2/10 or Equiv.				
D+	3/10 A 500VAC	FLQ- 3/10 or Equiv.	5A 500VAC	FNQ-5 or Equiv.	3.2A 250VAC	MDA- 3 2/10 or Equiv.				
D	3/10 A 500VAC	FLQ- 3/10 or Equiv.	10A 600VAC	KTK-10 or Equiv.	3.2A 250VAC	MDA- 3 2/10 or Equiv.				
E	3/10 A 500VAC	FLQ- 3/10 or Equiv.	10A 600VAC	KTK-10 or Equiv.	3.2A 250VAC	MDA- 3 2/10 or Equiv.	1/2 A 250VAC	ABC 1/2 or Equiv.		
F	3A 600VAC	ATM-3 or Equiv.	3A 500VAC	KTK-3 or Equiv.	3A 600VAC	KTK-3 or Equiv.	3A 600VAC	KTK-3 or Equiv.		
G+ 250HP			50A 600VAC	JJS or Equiv.	3 1/2 A 500VAC	FNQ- 3 1/2 or Equiv.	4A 500VAC	FNQ-4 or Equiv.	3A 500VAC	FNQ-3 or Equiv.
G+300HP			50A 600VAC	JJS or Equiv.	3 1/2 A 500VAC	FNQ- 3 1/2 or Equiv.	4A 500VAC	FNQ-4 or Equiv.	3A 500VAC	FNQ-3 or Equiv.
G+350HP			60A 600VAC	JJS or Equiv.	3 1/2 A 500VAC	FNQ- 3 1/2 or Equiv.	4A 500VAC	FNQ-4 or Equiv.	3A 500VAC	FNQ-3 or Equiv.
G+400HP			70A 600VAC	JJS or Equiv.	3 1/2 A 500VAC	FNQ- 3 1/2 or Equiv.	4A 500VAC	FNQ-4 or Equiv.	3A 500VAC	FNQ-3 or Equiv.
G+450HP			70A 600VAC	JJS or Equiv.	3 1/2 A 500VAC	FNQ- 3 1/2 or Equiv.	4A 500VAC	FNQ-4 or Equiv.	3A 500VAC	FNQ-3 or Equiv.

 Not applicable.

**Wire Size and Protection Devices**

**Table 3-5 230VAC Controls (3 Phase) Wire Size and Protection Devices**

Control Rating		Input Breaker (Amps)	Input Fuse (Amps)		Wire Gauge	
Amps	HP		Fast Acting	Time Delay	AWG	mm <sup>2</sup>
3	0.75	7	5	4	14	2.5
4	1	7	6	5	14	2.5
7	2	15	12	9	14	2.5
10	3	15	15	12	14	2.5
16	5	20	25	20	12	3.31
22	7.5	30	35	30	10	5.26
28	10	40	45	35	8	8.37
42	15	60	70	60	6	13.3
54	20	70	80	70	6	13.3
68	25	90	100	90	4	21.2
80	30	100	125	110	3	26.7
104	40	150	175	150	1	42.4
130	50	175	200	175	1/0	53.5
145	60	200	225	200	2/0	67.4
192	75	250	300	250	4/0	107.0

**Table 3-6 460VAC Controls (3 Phase) Wire Size and Protection Devices**

Control Rating		Input Breaker (Amps)	Input Fuse (Amps)		Wire Gauge	
Amps	HP		Fast Acting	Time Delay	AWG	mm <sup>2</sup>
2	0.75	3	2	2	14	2.5
2	1	3	3	2.5	14	2.5
4	2	7	5	4.5	14	2.5
5	3	7	8	6.3	14	2.5
8	5	15	12	10	14	2.5
11	7.5	15	17.5	15	14	2.5
14	10	20	20	17.5	12	3.31
21	15	30	30	25	10	5.26
27	20	40	40	35	10	5.26
34	25	50	50	45	8	8.37
40	30	50	60	50	8	8.37
52	40	70	80	70	6	13.3
65	50	90	100	90	4	21.2
77	60	100	125	100	3	26.7
96	75	125	150	125	2	33.6
124	100	175	200	175	1/0	53.5
156	125	200	250	200	2/0	67.4
180	150	225	300	250	3/0	85.0
240	200	300	350	300	(2) 2/0	(2) 67.4
302	250	400	450	400	(2) 4/0	(2) 107.0
361	300	450	600	450	(3) 2/0	(3) 67.4
414	350	500	650	500	(3) 3/0	(3) 85.0
477	400	600	750	600	(3) 4/0	(3) 107.0
515	450	650	800	700	(3) 250MCM	(3) 127.0
590	500	750	900	800	(3) 300MCM	(3) 152.0

Note: All wire sizes are based on 75°C copper wire. Higher temperature smaller gauge wire may be used per NEC and local codes. Recommended fuses/breakers are based on 40°C ambient, maximum continuous control output current and no harmonic current.

## Three Phase Input Power Connections

AC power and motor connections are different for controls that have a model number suffix of “EL” and “EK”. Be sure to use the correct procedure for your control.

Note: “EK” Controls are input phase sensitive. Be sure all connections are correct.

### “EL” suffix

The AC power and motor connections are shown in Figure 3-3. Overloads are not required. The 22H control has an electronic I<sup>2</sup>t motor overload protection. If motor overloads are desired, they should be sized according to the manufacturers specifications and installed between the motor and the T1, T2 and T3 terminals of the control.

1. Connect the incoming AC power wires from the protection devices to terminals A1, B1 and C1 at the 3% line reactor.
  2. Connect A2, B2 and C2 3% line reactor terminals to the L1, L2 and L3 power input terminals of the control.
  3. \* Connect earth ground to the “⊥” of the control. Be sure to comply with local codes.
- \* Grounding by using conduit or panel connection is not adequate. A separate conductor of the proper size must be used as a ground conductor.

**Figure 3-3 “EL” Control 3 Phase AC Power and Motor Connections**

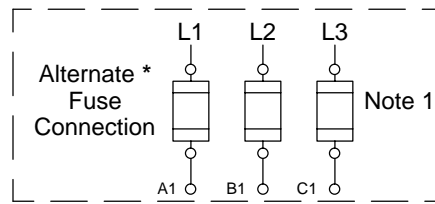
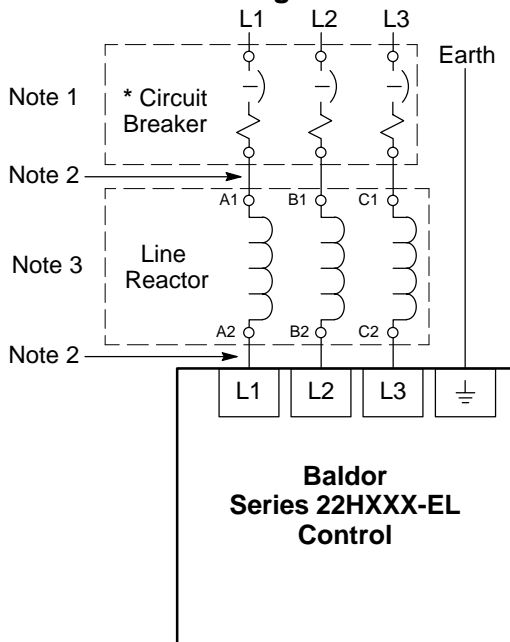

\* Optional components not provided with 22H Control.

#### Notes:

1. See “Protective Devices” described previously in this section.
2. Shield wires inside a metal conduit.
3. 3% Line Reactor is required at input.

See Recommended Tightening Torques in Section 7.

**“EK” suffix** (“EK” Controls are input phase sensitive. Check all connections).

The AC power and motor connections are shown in Figure 3-4. Overloads are not required. The 22H control has an electronic I<sup>2</sup>t motor overload protection. If motor overloads are desired, they should be sized according to the manufacturers specifications and installed between the motor and the T1, T2 and T3 terminals of the control.

1. Connect the incoming AC power wires from the protection devices to terminals A1, B1 and C1 of the 3% line reactor.
  2. Connect A2, B2 and C2 3% line reactor terminals to the L1, L2 and L3 of the boost regulator.
  3. Connect X1, X2 and X3 boost regulator terminals to X1, X2 and X3 of the control.
  4. \* Connect earth ground to the “⊥” of the control. Be sure to comply with local codes.
  5. Connect boost regulator terminals L1A, L2A and L3A to Filter terminals J1-1, J1-2 and J1-3, J1-2 and J1-3.
  6. Connect filter terminals J2-1, J2-2 and J2-3 to control terminals L1A, L2A and L3A.
- \* Grounding by using conduit or panel connection is not adequate. A separate conductor of the proper size must be used as a ground conductor.

**Figure 3-4 “EK” Control 3 Phase AC Power and Motor Connections (Size D, E & F)**

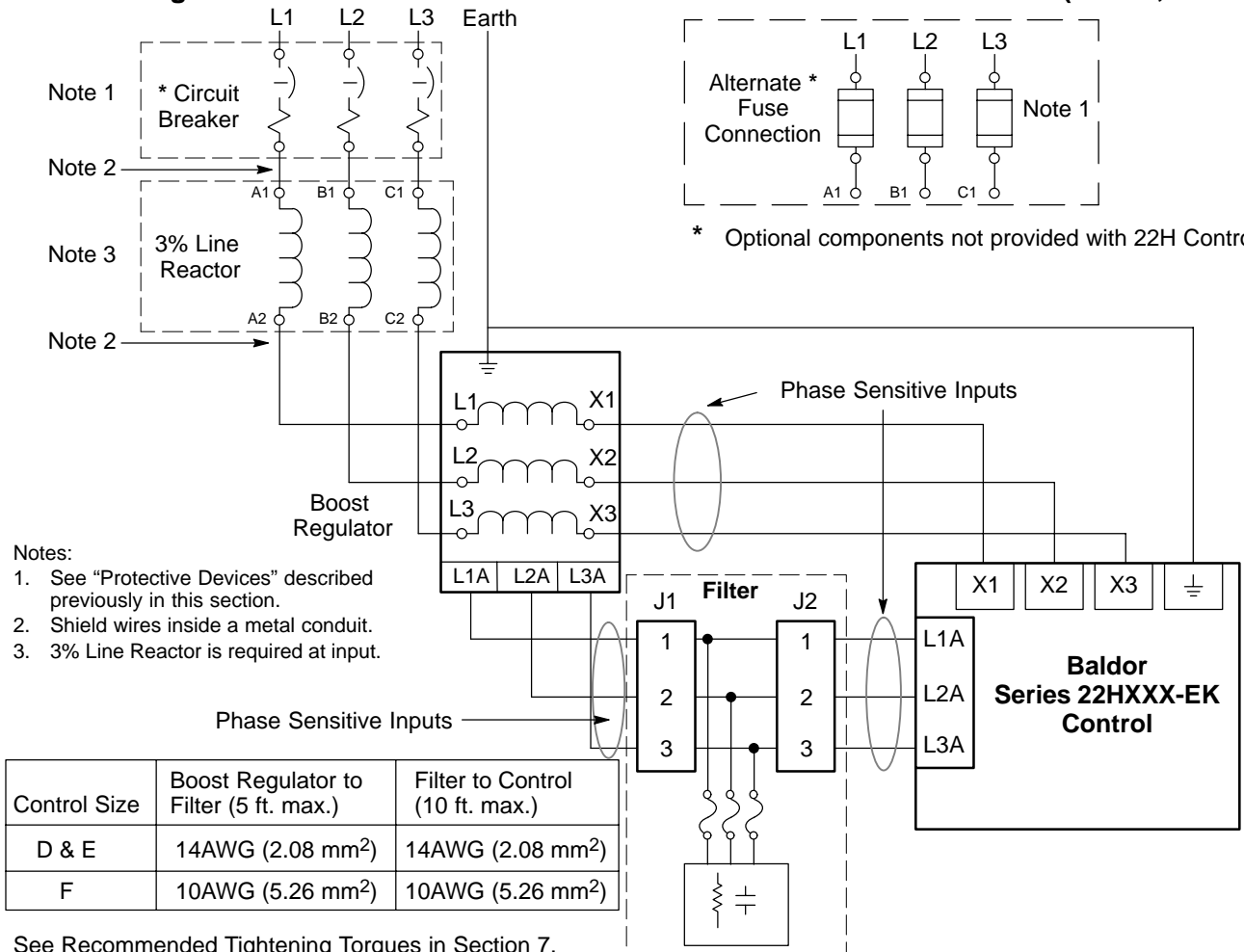

---

### Single Phase Operation

Single phase operation is not possible for Series 22H Line Regen Vector Controls.

### Operating the Control at a Reduced Input Voltage

Series 22H Controls use a DC Bus regulation technique that provides full output voltage (240VAC for 230VAC Controls; or 480VAC for 460VAC controls) for the full input voltage range. However, at reduced input voltages the output current of the control may have to be derated. Table 3-7 lists the % derating of the output current for various motor voltage ratings and input power voltage levels to the control.

**Table 3-7 Output Current Derating at Reduced Input Voltages (2.5KHz PWM)**

Input Voltage		% of Output Current after Derating		
230VAC Control	460VAC Control	240/480VAC Motor	230/440VAC Motor	208/400VAC Motor
180VAC	340VAC	77%	84%	93%
190VAC	360VAC	82%	89%	98%
208VAC	400VAC	90%	99%	100%
230VAC	440VAC	100%	100%	100%
240VAC	480VAC	100%	100%	100%

For example:

A 460VAC Control that has a 400VAC input line can provide 90% of the rated current to a 480VAC motor. In the Section 6 specifications we find our example 10HP control is ZD22H410-EL has a continuous current rating of 15 Amps. The derated current can be calculated as follows:  $15A \times 90\% = 13.5A$  derated value.

### Hardware Changes for Reduced Voltage Input

Size C+, D+, D, E, F and G+ controls all require modification for operation at a reduced line voltage (less than rated nominal). Table 3-8 defines the modifications for each enclosure size. Figure 3-1 shows the locations of the transformer locations for each enclosure size.

**Table 3-8 Hardware changes for 380-400VAC operation**

Enclosure Size	Control Transformer Tap Change	Contactors Transformer Tap Change	Fuse Block Connection Change
C+	Yes	No	
D+	Yes	No	
D	Yes	No	
E	Yes	Yes	
F	Yes	Yes	
G+	No	Yes	Yes

**Figure 3-1 Control and Contactor Transformer Locations**

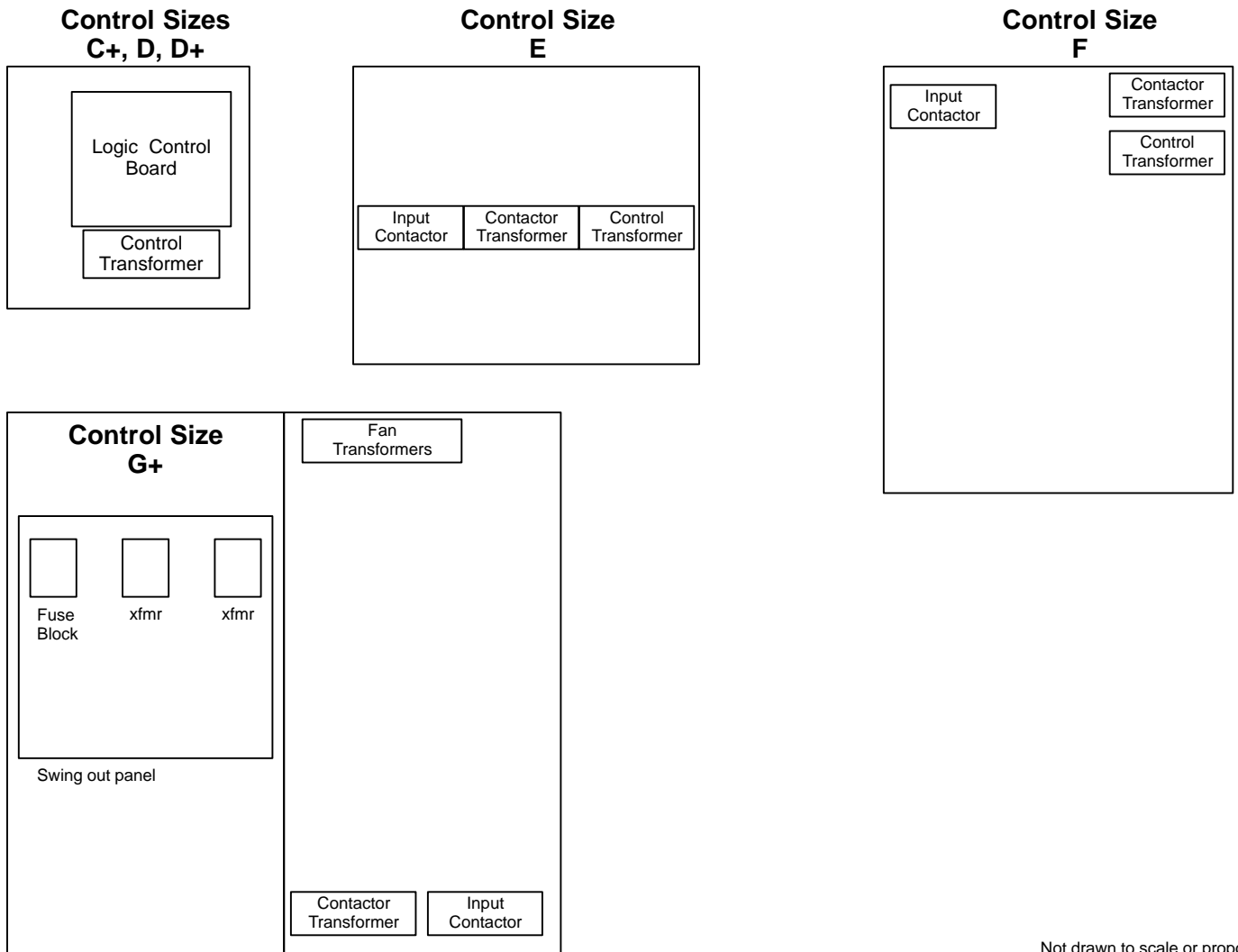

Not drawn to scale or proportion

**Size C+, D, D+ E, and F size control procedure:**

**Control Transformer**

1. Terminate drive operation and disable the control.
2. Remove all power sources from the control. If power has been applied, wait at least 5 minutes for bus capacitors to discharge.
3. Remove or open the front cover and locate the control transformer (Figure 3-2).
4. Remove the wire from terminal 5 of the control transformer.
5. Place the wire that was removed from terminal 5 onto terminal 4.
6. Install or close the front cover.



**Figure 3-2 Configuring the Control Transformer for 380 - 400 VAC Installation**

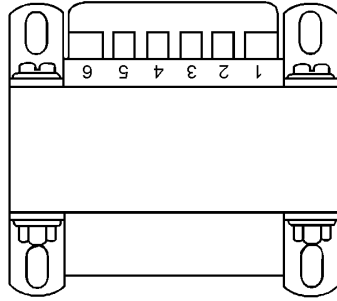

**Contactor Transformer**

Only size E and F controls require a change of the contactor transformer tap. See Figure 3-3. Use the taps (H1 to H5) that are correct for the input voltage.

**Figure 3-3 Contactor Transformer Tap Change (380 -400VAC Input)**

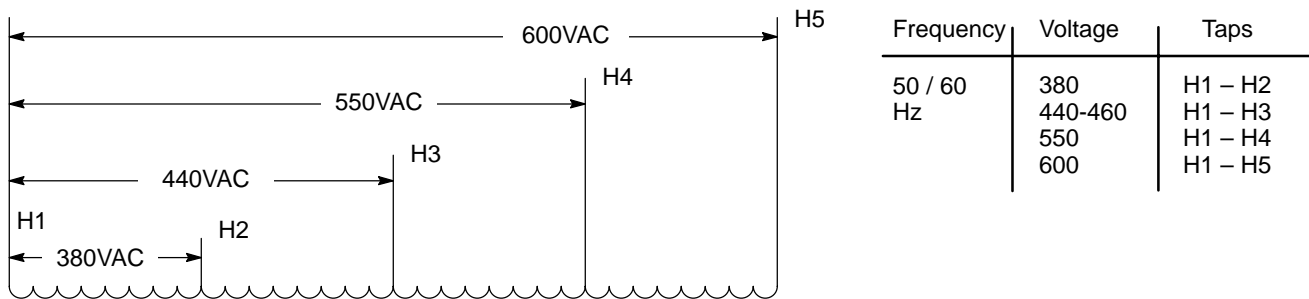

**Size G+and H control procedure:** (Refer to Figure 3-4.)

**Control Transformer**

1. Be sure drive operation is terminated and control is disabled.
2. Remove all power sources from the control. If power has been applied, wait at least 5 minutes for bus capacitors to discharge.
3. Remove or open the front cover. Locate the control transformer fuse block (see Figure 3-1).
4. Remove the wires from the two right side terminals (460VAC connection).
5. Place the wires on the center terminals as shown (380VAC connection).
6. Install or close the front cover.

**Figure 3-4 Configuring the Control Transformer Fuse Block for 380 - 400 VAC Installation**

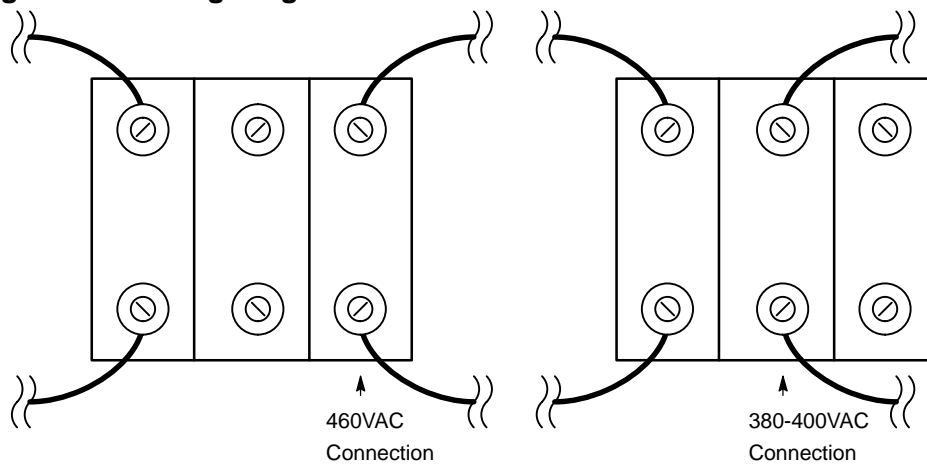

For Fuse Block, location refer to Figure 3-1.

## Motor Connections

Motor connections are shown in Figure 3-5.

### Figure 3-5 Motor Connections

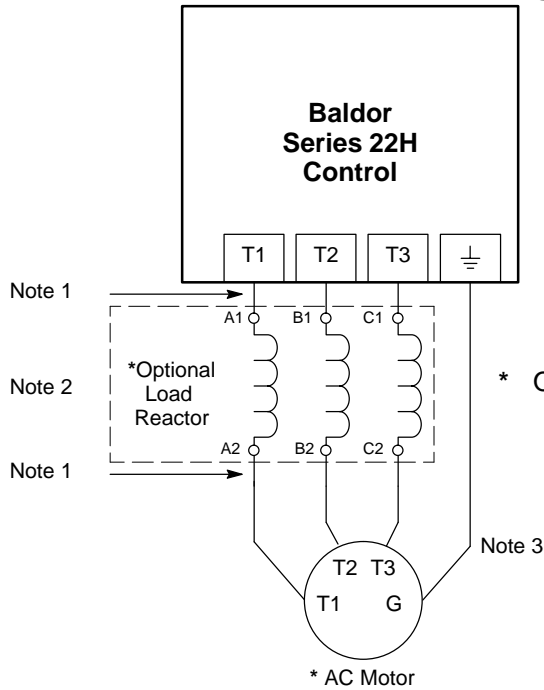

Notes:

1. Metal conduit should be used. Connect conduits so the use of Load Reactor or RC Device does not interrupt EMI/RFI shielding.
2. See Line/Load Reactors described previously in this section.
3. Use same gauge wire for Earth ground as for L1, L2 and L3.

\* Optional components not provided with 22H Control.

See recommended terminal tightening torques in Section 7.

## M-Contactor

If required by local codes or for safety reasons, an M-Contactor (motor circuit contactor) may be installed. However, incorrect installation or failure of the M-contactor or wiring may damage the control. If an M-Contactor is installed, the control must be disabled for at least 20msec before the M-Contactor is opened or the control may be damaged. M-Contactor connections are shown in Figure 3-6.

### Figure 3-6 Optional M-Contactor Connections

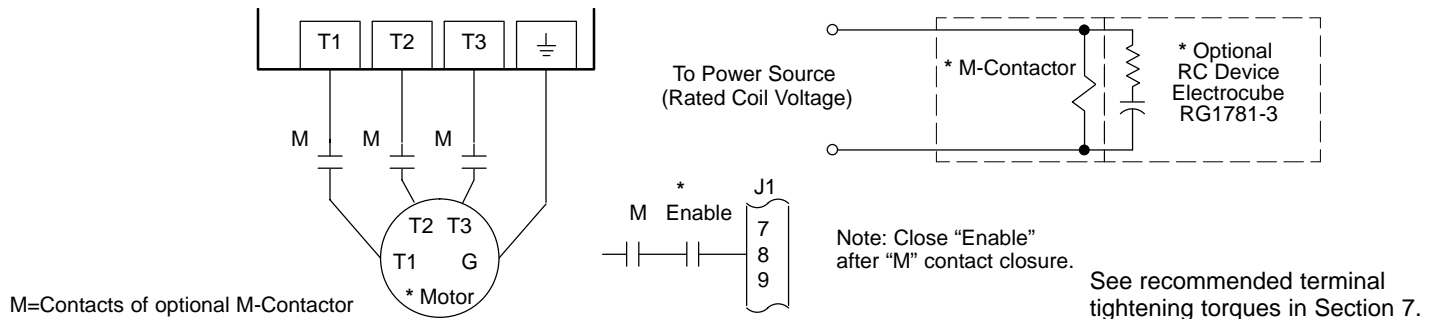

M=Contacts of optional M-Contactor

Note: Close "Enable" after "M" contact closure.

See recommended terminal tightening torques in Section 7.

## Encoder Installation

Electrical isolation of the encoder shaft and housing from the motor is required. Electrical isolation prevents capacitive coupling of motor noise that will corrupt the encoder signals. Baldor provides shielded wire for encoder connection. Figure 3-7 shows the electrical connections between the encoder and the encoder connector. Figure 3-8 shows the connections between the encoder connector and J1 of the control.

**Figure 3-7 Encoder Connections**

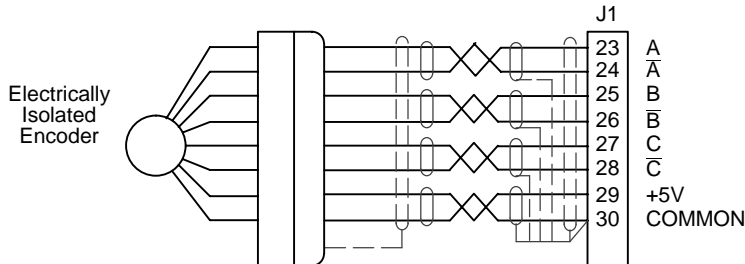

See recommended terminal tightening torques in Section 7.

**Figure 3-8 Control Connections**

<u>Encoder End</u>	<u>Control End</u>
A	J1-23
$\bar{A}$	J1-24
B	J1-25
$\bar{B}$	J1-26
Index(C)	J1-27
Index( $\bar{C}$ )	J1-28
+5VDC	J1-29
Common	J1-30
Shield	J1-30

### Single Ended Connections

Differential inputs are recommended for best noise immunity. If only single ended encoder signals are available, connect them to A, B, and INDEX (C) (J1-23, J1-25 and J1-27 respectively).

**Buffered Encoder Output** The control provides a buffered encoder output on pins J1-31 to J1-38. This output may be used by external hardware to monitor the encoder signals. It is recommended that this output only drive one output circuit load (a 26LS31 type device drives this output).

**Home (Orient) Switch Input** The Home or Orient function is active in the Bipolar and Serial modes and causes the motor shaft to rotate to a predefined home position. The homing function allows shaft rotation in the drive forward direction only. The home position is located when a machine mounted switch or the encoder “Index” pulse is activated (closed). Home is defined by a rising signal edge at terminal J1-27. The shaft will continue to rotate only in a “Drive Forward” direction for a user defined offset value. The offset is programmed in the Level 2 Miscellaneous Homing Offset parameter. The speed at which the motor will “Home” or orient is set with the Level 2 Miscellaneous Homing Speed parameter.

A machine mounted switch may be used to define the Home position in place of the encoder index channel. A differential line driver output from a solid state switch is preferred for best noise immunity. Connect this differential output to terminals J1-27 and J1-28.

A single ended solid-state switch or limit switch should be wired as shown in Figure 3-9. Regardless of the type of switch used, clean rising and falling edges at J1-27 are required for accurate positioning.

Note: A control may require dynamic brake hardware for Orient (Homing) function to work. The control may trip without dynamic brake hardware installed.

**Figure 3-9 Typical Home or Orient Switch Connections**

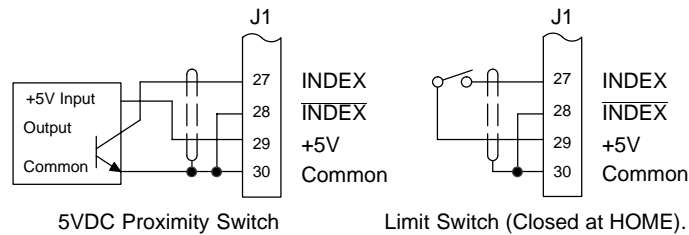

See recommended terminal tightening torques in Section 7.

**Example:**

If the drive is operating in the forward direction when the “Orient” J1-11 input is closed, the drive will decel at “DECEL #1” speed. Then continue in the forward direction at the “Homing Speed” until the index pulse is received. The drive will continue past the int index in the forward direction by the amount of the “Homing Offset”. The drive will then stop and maintain position.

## Control Board Jumpers

### Converter Section Control Board

**Figure 3-10 Converter Control Board Jumper JP1 Location**

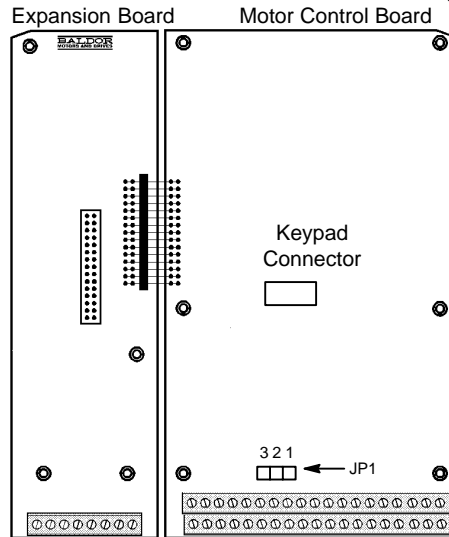

See recommended terminal tightening torques in Section 7.

**Table 3-9 Converter Control Board Jumper**

Jumper	Jumper Position	Description of Jumper Position Setting
JP1	1-2	Voltage Speed Command Signal. (Factory Setting)
	2-3	4-20mA Speed Command Signal.

### Inverter Section Control Board

**Figure 3-11 Inverter Control Board Jumper Locations**

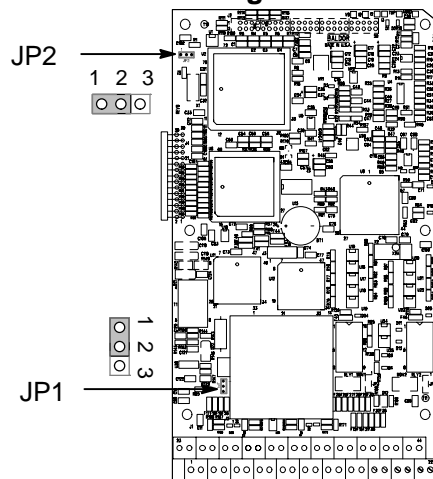

Refer to Table 3-10 for jumper placement information.

See recommended terminal tightening torques in Section 7.

**Table 3-10 Inverter Control Board Jumper**

Jumper	Jumper Position	Description of Jumper Position Setting
JP1	1-2	Voltage Speed Command Signal. (Factory Setting)
	2-3	4-20mA input at Analog #2
JP2	1-2	Factory Setting
	2-3	Not used.

## Analog Inputs

Two analog inputs are available: analog input #1 (J1-1 and J1-2) and analog input #2 (J1-4 and J1-5) as shown in Figure 3-12. Either analog input may be selected in the Level 1 INPUT block, Command Select parameter value. Analog input #1 is selected if the parameter value is "Potentiometer". Analog input #2 is selected if the parameter value is "+/-10Volts, +/-5 Volts or 4-20mA". Figure 3-13 shows the equivalent circuits of the Analog Inputs.

**Figure 3-12 Analog Inputs and Outputs**

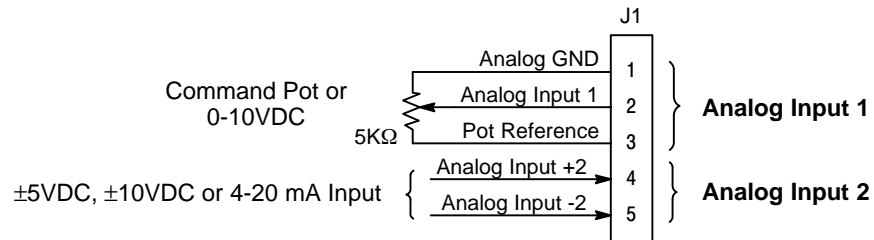

See recommended terminal tightening torques in Section 7.

### Analog Input #1 (Single Ended)

When using a potentiometer as the speed command, process feedback or setpoint source, the Level 1 Input block COMMAND SELECT parameter must be set to "POTENTIOMETER".

Note: A potentiometer value of 5kΩ to 10kΩ, 0.5 watt may be used.

#### Parameter Selection

The single ended analog input #1 can be used in one of three ways:

1. Speed or Torque command (Level 1 Input block, Command Select=Potentiometer).
2. Process Feedback (Level 2 Process Control block, Process Feedback=Potentiometer).
3. Setpoint Source (Level 2 Process Control block, Setpoint Source=Potentiometer).

When using Analog Input #1, the respective parameter must be set to "POTENTIOMETER".

### Analog Input #2 (Differential)

Analog input #2 accepts a differential command 0-5VDC, 0-10VDC, ±5VDC, ±10VDC or 4-20 mA. If pin J1-4 is positive with respect to pin 5, the motor will rotate in the forward direction. If pin J1-4 is negative with respect to pin 5, the motor will rotate in the reverse direction. JP1 must be set for voltage or current operation as required. Analog Input #2 can be connected for single ended operation by grounding either of the inputs, provided the common mode voltage range is not exceeded.

Note: The common mode voltage can be measured with a voltmeter. Apply the maximum command voltage to analog input 2 (J1-4, 5). Measure the AC and DC voltage across J1-1 to J1-4. Add the AC and DC readings together. Measure the AC and DC voltage from J1-1 to J1-5. Add the AC and DC readings together.

If either of these measurement totals exceeds a total of ±15 volts, then the common mode voltage range has been exceeded. To correct this condition, either change the command source or isolate the command signal with a signal isolator.

**Figure 3-13 Analog Inputs Equivalent Circuits**

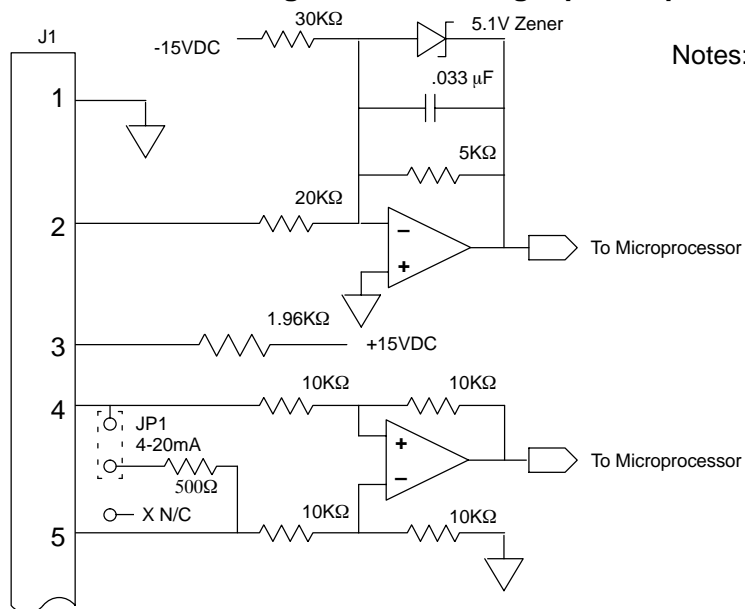

Notes:

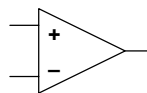

All OP Amps are TL082 or TL084



Analog Ground is separated from Chassis Ground. Electrically they are separated by an RC network.

See recommended terminal tightening torques in Section 7.

**Analog Outputs**

Two programmable analog outputs are provided on J1-6 and J1-7. See Figure 3-14. These outputs are scaled 0 - 5 VDC (1mA maximum output current) and can be used to provide real-time status of various control conditions. The output conditions are defined in Table 4-4 of Section 4 of this manual.

The return for these outputs is J1-1 analog ground. Each output is programmed in the Level 1 Output block.

**Figure 3-14 Analog Outputs Equivalent Circuits**

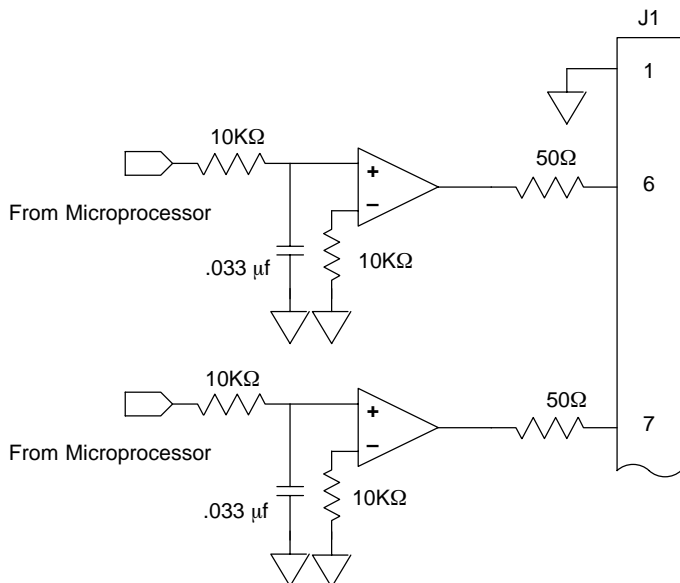

Notes:

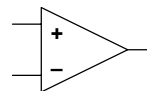

All OP Amps are TL082 or TL084



Analog Ground is separated from Chassis Ground. Electrically they are separated by an RC network.

See recommended terminal tightening torques in Section 7.

## Control Circuit Connections

There are two control boards in a Series 22H Vector Control. The Converter Control Board is used to rectify and process the incoming power. The Inverter Control Board provides the inverting and power output functions. The keypad is normally connected to the Inverter Control Board. Each converter board has its own J1 terminal strip. The Inverter Control Board provides the user interface for most external connections.

### Converter Control Board Connections

All necessary connections for the Converter Control Board have been made at the factory prior to shipment.

The jumper between J1-8 and J1-17 provides the enable signal to allow converter operation. The jumper between J1-39 and J1-40 provides +24VDC from the internal supply to allow the opto isolated input at J1-8 to operate. These jumpers should remain installed at all times.

Sometimes it is necessary to troubleshoot the converter section using the isolated opto outputs. Figure 3-15 shows how to connect external relays to the board to “Sink” or “Source” the relay current.

The function of each opto output is as follows: (these functions cannot be changed)

J1-19	Ready
J1-20	At Voltage
J1-21	Fault
J1-22	Overtemperature Warning

**Figure 3-15 Converter Control Board Opto Output Wiring**

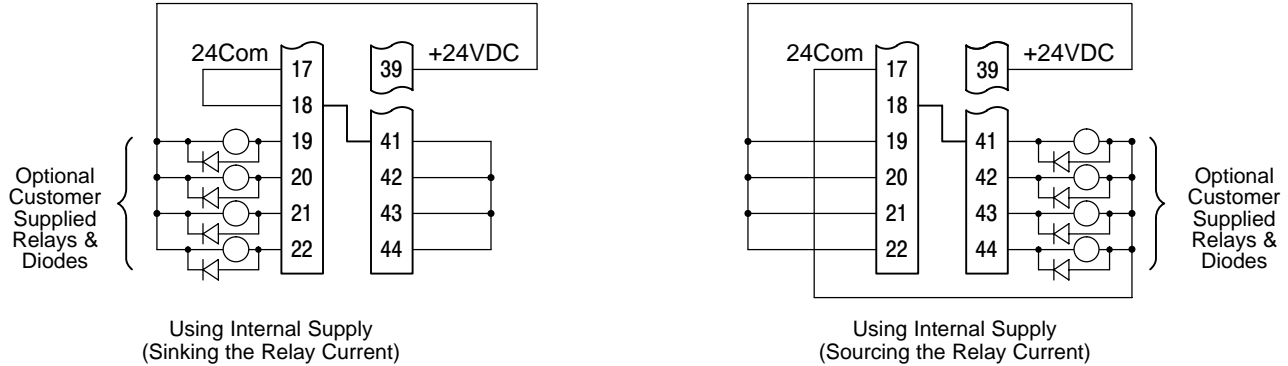

Note: Add appropriately rated protective device for AC relay (snubber) or DC relay (diode).

See recommended terminal tightening torques in Section 7.



## Inverter Control Board Connections

Ten operating modes are available in the Series 22H vector control. These operating modes define the basic motor control setup and the operation of the input and output terminals. After the circuit connections are completed, the operating mode is selected by programming the Level 1 Input block, Operating Mode parameter.

Available operating modes include:

- Keypad Control
- Standard Run, 3 Wire Control
- 15 Speed, 2 Wire Control
- Three Speed, 2 Wire Control
- Three Speed, 3 Wire Control
- Serial
- Bipolar Speed or Torque
- Process Control
- EPOT, 2 Wire Control
- EPOT, 3 Wire Control

Each mode requires connections to the J1 terminal strip (except keypad and serial modes, all connections are optional). The J1 terminal strip is shown in Figure 3-16. The connection of each input or output signal is described in the following pages.

**Figure 3-16 Control Signal Connections**

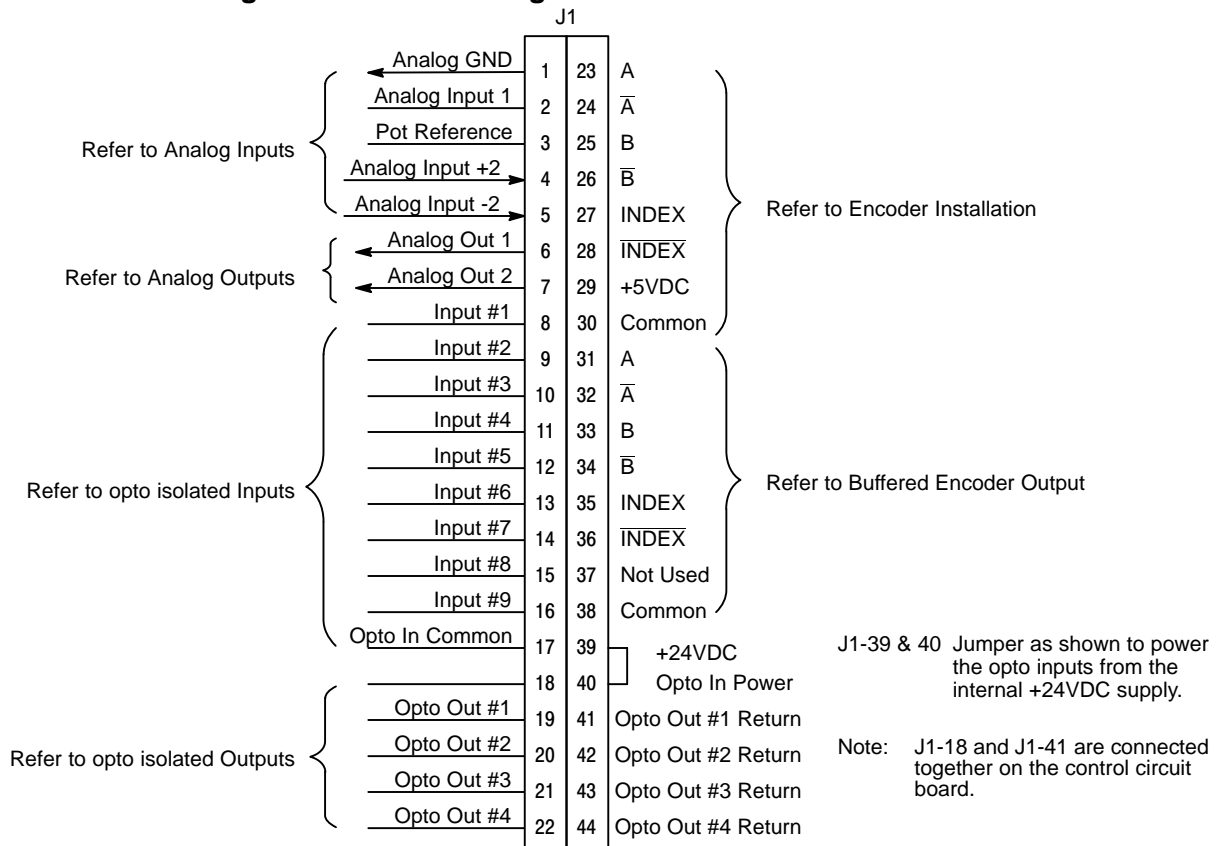

See recommended terminal tightening torques in Section 7.

## Serial Mode

The Serial operating mode requires one of the optional Serial Interface expansion boards (RS232 or 422/485). Installation and operation information for these serial expansion boards is provided in Serial Communications expansion board manual MN1310. This manual is shipped with the serial expansion board.

**Keypad Mode Connections** The Keypad operating mode allows the control to be operated from the keypad. This mode requires no connections to J1. However, the Enable, Stop and External Trip inputs may optionally be used. All other opto inputs remain inactive. The analog outputs and opto-outputs remain active at all times. See Figure 3-17.

**Parameter Selection**

For operation in Keypad mode, set the Level 1 Input block, Operating Mode parameter to Keypad. The STOP key can operate in two ways:

- Press STOP key one time to brake or coast to stop.
- Press STOP key two times to disable control.

To use the Enable input, J1-8 must be connected and the Local Enable INP parameter in the Level 2 Protection block must be set to ON. The Enable line is normally closed. When opened, the motor will COAST to a stop. When the enable line is again closed, the motor will not start until a new direction command is received from the keypad.

To use the Stop input, J1-11 must be connected and the Level 1 Keypad Setup block, LOC. Hot Start parameter must be set to ON. The Stop line is normally closed. When opened, the motor will COAST or REGEN to a stop depending upon the setting of Level 1 Keypad Setup block Keypad Stop Mode parameter value. Closing the input will immediately start the motor.

The External Trip input causes a fault condition during a motor over temperature condition (when normally closed input opens). The External Trip input (J1-16) must be connected and the External Trip parameter in the Level 2 Protection block must be set to "ON". When J1-16 is opened, an external trip fault occurs. The control will disable and the motor coasts to a stop. An external trip fault is displayed on the keypad display (also logged into the fault log).

**Figure 3-17 Keypad Control Connection Diagram**

- J1-8 If J1-8 is connected, you must set Level 2 Protection block, Local Enable INP parameter to "ON" to activate the opto input. CLOSED allows normal operation. OPEN disables the control and motor coasts to a stop.
- J1-11 If J1-11 is connected, you must set Level 1 Keypad Setup block, Loc. Hot Start parameter to to "ON" to activate the opto input. CLOSED allows normal operation. OPEN motor decels to stop (depending on Keypad Stop mode). The motor will restart when J1-11 closes after open (if the keypad FWD or REV key is still pressed).
- J1-16 If J1-16 is connected, you must set Level 2 Protection block, External Trip to "ON" to activate the opto input. CLOSED allows normal operation. OPEN causes an external trip to be received by the control. The control will disable and display external trip. When this occurs, the motor stop command is issued, drive operation is terminated and an external trip fault is displayed on the keypad display (also logged into the fault log).

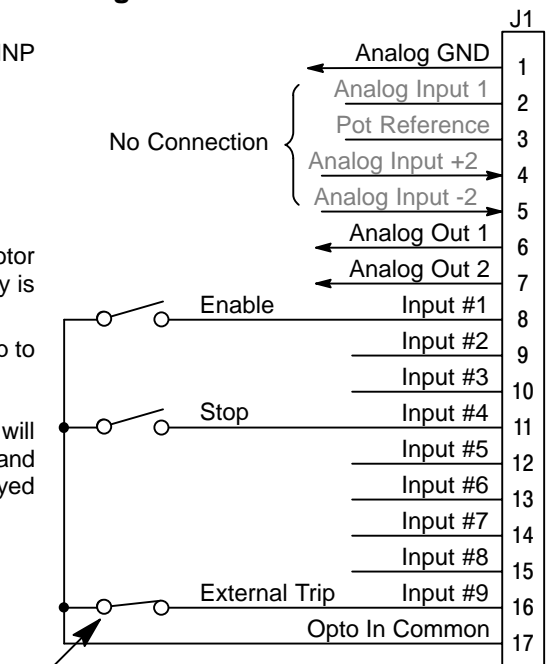

See recommended terminal tightening torques in Section 7.

## Standard Run 3 Wire Mode Connections

In Standard Run mode, the control is operated by the opto isolated inputs at J1-8 through J1-16 and the analog command input. The opto inputs can be switches as shown in Figure 3-18 or logic signals from another device. The external trip opto input at J1-16 is active if connected as shown and the Level 2 Protection block, External Trip parameter is set to ON.

For 4–20mA operation, refer to Table 3-10. Analog input 2 can then be used for 4–20mA operation.

**Figure 3-18 Standard Run 3-Wire Connection Diagram**

J1-8	CLOSED allows normal control operation. OPEN disables the control and motor coasts to a stop.
J1-9	MOMENTARY CLOSED starts motor operation in the Forward direction. In JOG mode (J1-12 CLOSED), continuous CLOSED jogs motor in the Forward direction.
J1-10	MOMENTARY CLOSED starts motor operation in the Reverse direction. In JOG mode (J1-12 CLOSED), CONTINUOUS closed JOGS motor in the Reverse direction.
J1-11	MOMENTARY OPEN causes motor to decel to stop (depending on Keypad Stop Mode parameter setting). Motor current continues to be applied to the motor.
J1-12	CLOSED places control in JOG mode, Forward and Reverse run are used to jog the motor.
J1-13	CLOSED selects group 2. OPEN selects ACC / DEC / S-CURVE group 1.
J1-14	CLOSED selects preset speed #1, (J1-12, will override this preset speed). OPEN allows speed command from Analog input #1 or #2 or Jog.
J1-15	CLOSED to reset fault condition. OPEN to run.
J1-16	If J1-16 is connected, you must set Level 2 Protection block, External Trip to "ON" to activate the opto input. CLOSED allows normal control operation. OPEN causes an external trip to be received by the control. The control will disable and display external trip. When this occurs, the motor stop command is issued, drive operation is terminated and an external trip fault is displayed on the keypad display (also logged into the fault log).

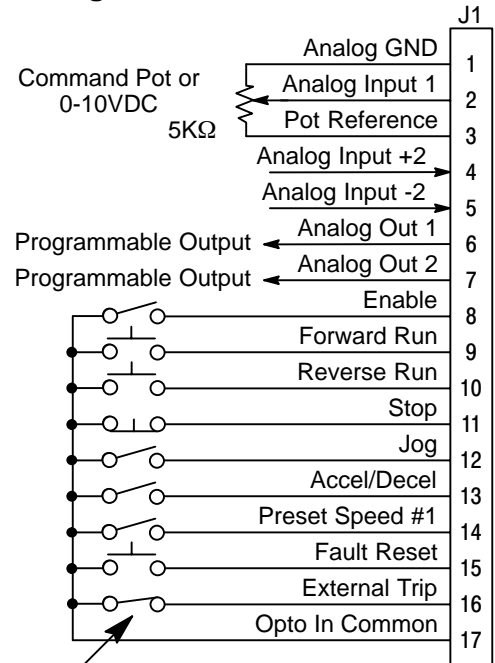

Refer to Figure 3-26.

See recommended terminal tightening torques in Section 7.

**15 Speed 2-Wire Mode Connections** Switch Truth Table is defined in Table 3-11.

Operation in the 15 Speed 2-Wire mode is controlled by the Opto Isolated inputs at J1-8 through J1-16. The Opto inputs can be switches as shown in Figure 3-19 or logic signals from another device.

Switched inputs at J1-11 through J1-14 allow selection of 15 preset speeds and provide Fault Reset as defined in Table 3-11.

**Figure 3-19 15 Speed 2-Wire Control Connection Diagram**

- J1-8 CLOSED allows normal control operation.  
OPEN disables the control and motor coasts to a stop.
- J1-9 CLOSED operates the motor in the Forward direction (with J1-10 open).  
OPEN motor decels to stop (depending on Keypad Stop mode parameter setting).
- J1-10 CLOSED operates motor in the Reverse direction (with J1-9 open).  
OPEN motor decels to stop depending on Keypad Stop mode parameter setting.
- J1-11 to 14 Selects programmed preset speeds as defined in Table 3-11.
- J1-15 Selects ACC/DEC group. OPEN selects group 1. CLOSED selects group 2.
- J1-16 If J1-16 is connected, you must set Level 2 Protection block, External Trip to "ON" to activate the opto input.  
CLOSED allows normal control operation.  
OPEN causes an external trip to be received by the control. The control will disable and display external trip. When this occurs, the motor stop command is issued, drive operation is terminated and an external trip fault is displayed on the keypad display (also logged into the fault log).

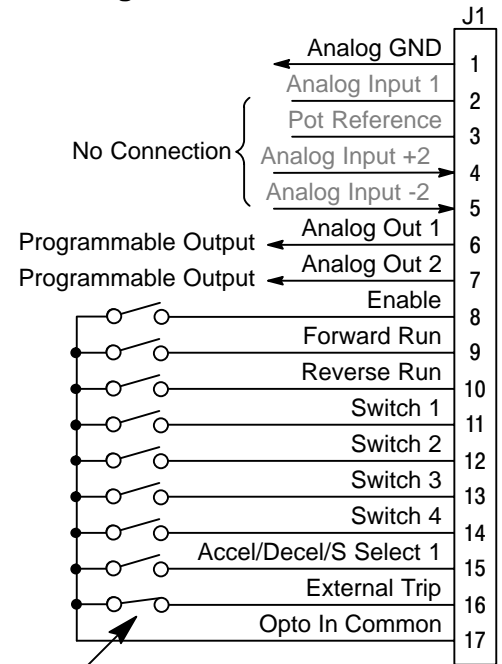

See recommended terminal tightening torques in Section 7.

**Table 3-11 Switch Truth Table for 15 Speed, 2 Wire Control Mode**

Function	J1-11	J1-12	J1-13	J1-14
Preset 1	Open	Open	Open	Open
Preset 2	Closed	Open	Open	Open
Preset 3	Open	Closed	Open	Open
Preset 4	Closed	Closed	Open	Open
Preset 5	Open	Open	Closed	Open
Preset 6	Closed	Open	Closed	Open
Preset 7	Open	Closed	Closed	Open
Preset 8	Closed	Closed	Closed	Open
Preset 9	Open	Open	Open	Closed
Preset 10	Closed	Open	Open	Closed
Preset 11	Open	Closed	Open	Closed
Preset 12	Closed	Closed	Open	Closed
Preset 13	Open	Open	Closed	Closed
Preset 14	Closed	Open	Closed	Closed
Preset 15	Open	Closed	Closed	Closed
Fault Reset	Closed	Closed	Closed	Closed

### 3 Speed Analog 2 Wire Operating Mode

Allows selection of 3 preset speeds with 2 wire inputs. The opto inputs can be switches as shown in Figure 3-20 or logic signals from another device.

The values of the preset speeds are set in the Level 1 Preset Speeds block, Preset Speed #1, Preset Speed #2 and Preset Speed #3.

**Figure 3-20 3 SPD ANA 2 Wire Control Connection Diagram**

- J1-8 CLOSED allows normal operation.  
OPEN disables the control and the motor coasts to a stop.
- J1-9 CLOSED operates the motor in the Forward direction (with J1-10 open).  
OPEN motor decels to stop (depending on Keypad Stop mode).
- J1-10 CLOSED operates the motor in the Reverse direction (with J1-9 open).  
OPEN motor decels to stop (depending on Keypad Stop mode).
- Note: Closing both J1-9 and J1-10 at the same time will reset a fault condition.
- J1-11 CLOSED selects Analog Input #1.  
OPEN selects Level 1 Input block, Command Select parameter.
- Note: If Command Select (Level 1 Input block) is set to Potentiometer, then Analog Input #1 is always selected regardless of this switch position.
- J1-12 CLOSED selects STOP/START and Reset commands from terminal strip.  
OPEN selects STOP/START and Reset commands from Keypad.
- J1-13 CLOSED selects Level 1 Input block, Command Select parameter.  
OPEN selects speed commanded from Keypad.
- Note: When changing from Terminal Strip to Keypad (J1-12 or J1-13) the motor speed and direction will remain the same after the change.
- J1-14 Selects preset speeds as defined in the Speed Select Table (Table 3-12).
- J1-15 Selects preset speeds as defined in the Speed Select Table (Table 3-12).
- J1-16 If J1-16 is connected, you must set Level 2 Protection block, External Trip to "ON" to activate the opto input.  
CLOSED allows normal operation.  
OPEN causes an external trip to be received by the control. The control will disable and display external trip. When this occurs, the motor stop command is issued, drive operation is terminated and an external trip fault is displayed on the keypad display (also logged into the fault log).

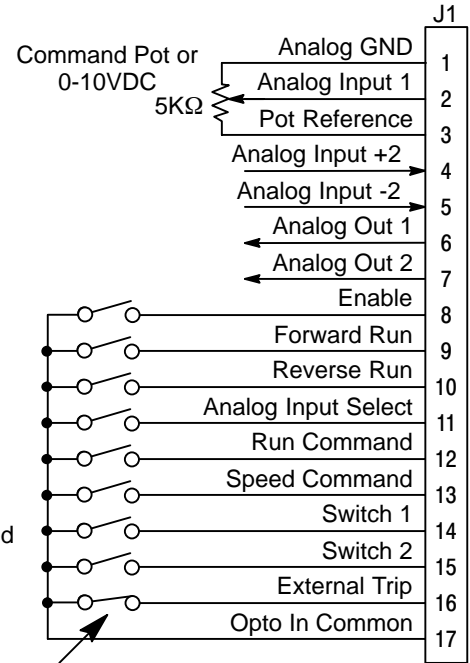

Refer to Figure 3-26.

See recommended terminal tightening torques in Section 7.

**Table 3-12 Speed Select Table**

J1-14	J1-15	Command
OPEN	OPEN	Analog Input (Command Select)
CLOSED	OPEN	Preset #1
OPEN	CLOSED	Preset #2
CLOSED	CLOSED	Preset #3

### 3 Speed Analog 3 Wire Operating Mode

Allows selection of 3 preset speeds with 3 wire inputs. The opto inputs can be switches as shown in Figure 3-21 or logic signals from another device.

The values of the preset speeds are set in the Level 1 Preset Speeds block, Preset Speed #1, Preset Speed #2 and Preset Speed #3.

**Figure 3-21 3 SPD ANA 3 Wire Control Connection Diagram**

- J1-8      CLOSED allows normal operation.  
            OPEN disables the control and the motor coasts to a stop.
- J1-9      MOMENTARY CLOSED starts motor operation in the Forward direction.
- J1-10     MOMENTARY CLOSED starts motor operation in the Reverse direction.  
            Note: Closing both J1-9 and J1-10 at the same time will reset a fault condition.
- J1-11     Momentary OPEN motor decels to stop (depending on Keypad Stop mode).
- J1-12     CLOSED selects STOP/START and Reset commands from terminal strip.  
            OPEN selects STOP/START and Reset commands from Keypad.
- J1-13     CLOSED selects Level 1 Input block, Command Select parameter.  
            OPEN selects speed commanded from Keypad.  
            Note: When changing from Terminal Strip to Keypad (J1-12 or J1-13) the motor speed and direction will remain the same after the change.
- J1-14     Selects preset speeds as defined in the Speed Select Table (Table 3-13).
- J1-15     Selects preset speeds as defined in the Speed Select Table (Table 3-13).
- J1-16     If J1-16 is connected, you must set Level 2 Protection block, External Trip to "ON" to activate the opto input.  
            CLOSED allows normal operation.  
            OPEN causes an external trip to be received by the control. The control will disable and display external trip. When this occurs, the motor stop command is issued, drive operation is terminated and an external trip fault is displayed on the keypad display (also logged into the fault log).

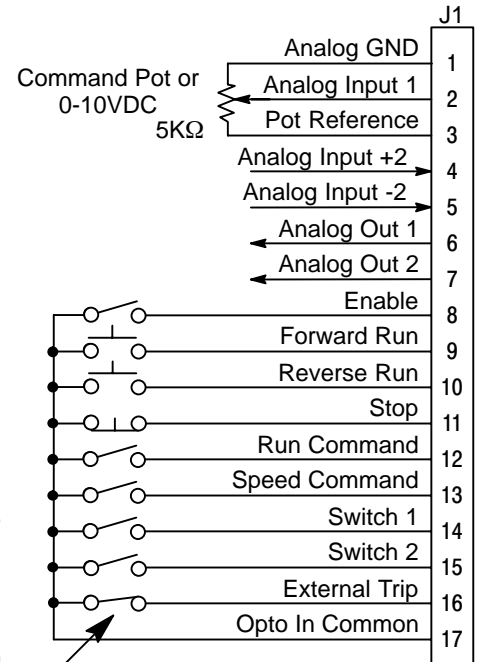

Refer to Figure 3-26.

See recommended terminal tightening torques in Section 7.

**Table 3-13 Speed Select Table**

J1-14	J1-15	Command
OPEN	OPEN	Analog Input (Command Select)
CLOSED	OPEN	Preset #1
OPEN	CLOSED	Preset #2
CLOSED	CLOSED	Preset #3

## Bipolar Speed and Torque Mode Connections

Provides bipolar speed or torque control. Also, you may store up to four (4) complete sets of operating parameters. This is important if you wish to store and use different acceleration rates, speed commands, jog speeds or to store tuning parameter values for different motors etc. The opto inputs can be switches as shown in Figure 3-22 or logic signals from another device.

**Figure 3-22 Bipolar Speed or Torque Connection Diagram**

- J1-8 CLOSED allows normal operation.  
OPEN disables the control & motor coasts to a stop.
- J1-9 CLOSED to enable operation in the Forward direction.  
OPEN TO DISABLE Forward operation (drive will brake to a stop if a Forward command is still present).  
Reverse operation is still possible if J1-10 is closed.
- J1-10 CLOSED to enable operation in the Reverse direction.  
OPEN to disable Reverse operation (drive will brake to a stop if a Reverse command is still present).  
Forward operation is still possible if J1-9 is closed.
- Note: If J1-9 and J1-10 are both opened, the drive will brake to a stop.
- J1-11 CLOSED causes the motor to rotate in the forward direction until the load reaches a marker or external switch location.  
OPEN allows normal operation.
- J1-12 CLOSED puts the control in torque command mode.  
OPEN puts the control in speed (velocity) command mode.
- Note: If a stop command is issued while in the torque (current) mode, the control will stop but will not maintain position (zero current). This is different than zero speed operation for the velocity mode.
- J1-13 & 14 Select from four parameter tables as defined in Table 3-14.
- J1-15 Momentary CLOSED to reset fault condition.  
OPEN allows normal operation.
- J1-16 If J1-16 is connected, you must set Level 2 Protection block, External Trip to "ON" to activate the opto input.  
CLOSED allows normal operation.  
OPEN causes an external trip to be received by the control. The control will disable and display external trip. When this occurs, the motor stop command is issued, drive operation is terminated and an external trip fault is displayed on the keypad display (also logged into the fault log).

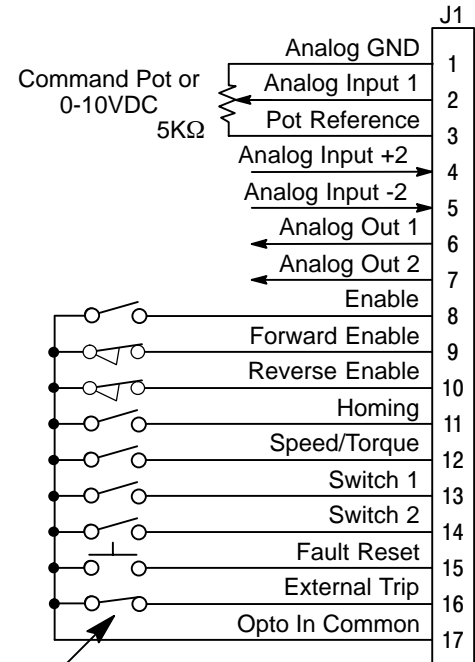

Refer to Figure 3-26.

See recommended terminal tightening torques in Section 7.

**Table 3-14 Bipolar Mode Table Select Truth Table**

Function	J1-13	J1-14
Parameter Table #0	Open	Open
Parameter Table #1	Closed	Open
Parameter Table #2	Open	Closed
Parameter Table #3	Closed	Closed

Note: See multiple parameter sets.

---

## Multiple Parameter Sets

The following procedure allows you to program up to four complete sets of parameter values and to use these multiple parameter sets. When programming each parameter set, use the ENTER key to accept and automatically save parameter values.

Note: The control can be programmed in the REMOTE mode with the drive enabled. The control must be disabled to change the operating mode parameter and the operating mode can not be stored in a parameter table.

1. If this is a new installation, do this procedure after the Pre-Operation Checklist and Power-Up Procedures at the end of this section.
2. Set the Level 1 INPUT block, Operating Mode parameter value to BIPOLAR in each of the parameter sets.
3. Set switches J1-13 and J1-14 to Parameter Table #0 (both switches open). Be sure switches J1-9 and J1-10 are OPEN, J1-8 is CLOSED. Enter all parameter values, and autotune as instructed in Section 3 of this manual. This creates and saves the first parameter set which is numbered Table#0.
4. Set switches J1-13 and J1-14 to Parameter Table #1. Be sure switches J1-9 and J1-10 are OPEN, J1-8 is CLOSED. Enter all parameter values, and autotune as instructed in Section 3 of this manual. This creates and saves the second parameter set which is numbered Table#1.
5. Set switches J1-13 and J1-14 to Parameter Table #2. Be sure switches J1-9 and J1-10 are OPEN, J1-8 is CLOSED. Enter all parameter values, and autotune as instructed in Section 3 of this manual. This creates and saves the third parameter set which is numbered Table#2.
6. Set switches J1-13 and J1-14 to Parameter Table #3. Be sure switches J1-9 and J1-10 are OPEN, J1-8 is CLOSED. Enter all parameter values, and autotune as instructed in Section 3 of this manual. This creates and saves the final parameter set which is numbered Table#3.
7. Remember that to change the value of a parameter in one of the parameter tables, you must first select the table using the switches. You cannot change a value in a table until you have first selected that table.

Note: Preset speed does not apply to table select.



**Process Mode Connections** The process control mode provides an auxiliary closed loop general purpose PID set point control. The process control loop may be configured in various ways and detailed descriptions of the process mode are given in MN707 "Introduction to Process Control". The opto inputs can be switches as shown in Figure 3-23 or logic signals from another device.

**Figure 3-23 Process Mode Connection Diagram**

- J1-8 CLOSED allows normal operation.  
OPEN disables the control & motor coasts to a stop.
  - J1-9 CLOSED to enable operation in the Forward direction.  
OPEN TO DISABLE Forward operation (drive will brake to a stop if a Forward command is still present). Reverse operation is still possible if J1-10 is closed.
  - J1-10 CLOSED to enable operation in the Reverse direction.  
OPEN to disable Reverse operation (drive will brake to a stop if a Reverse command is still present). Forward operation is still possible if J1-9 is closed.
- Note: If J1-9 and J1-10 are both opened, the drive will brake to a stop.
- J1-11 CLOSED = TABLE 1, OPEN = TABLE 0. (See multiple parameter sets.)
  - J1-12 CLOSED, the control is in torque command mode.  
OPEN, the control is in speed (velocity) command mode.
- Note: If a stop command is issued while in the torque (current) mode, the control will stop but will not maintain position (zero current). This is different than zero speed operation for the velocity mode.
- J1-13 CLOSED to enable the Process Mode.
  - J1-14 CLOSED places control in JOG mode. The control will only JOG in the forward direction.
  - J1-15 CLOSED to reset a fault condition.  
OPEN to run.
  - J1-16 If J1-16 is connected, you must set Level 2 Protection block, External Trip to "ON" to activate the opto input.  
CLOSED allows normal operation.  
OPEN causes an external trip to be received by the control. The control will disable and display external trip. When this occurs, the motor stop command is issued, drive operation is terminated and an external trip fault is displayed on the keypad display (also logged into the fault log).

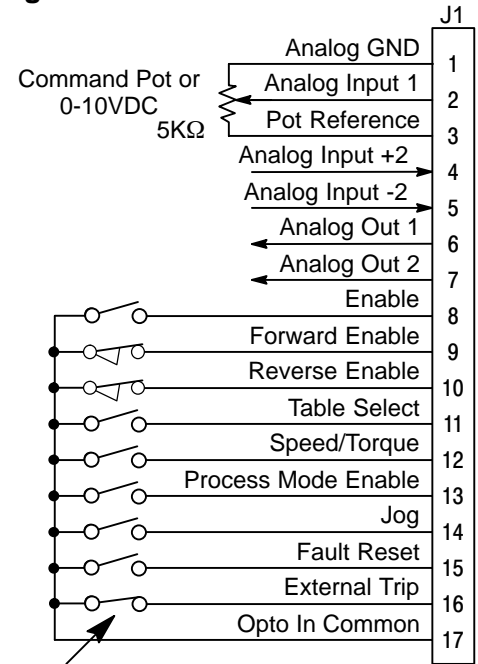

See recommended terminal tightening torques in Section 7.

**Table 3-15 Process Mode Input Signal Compatibility**

Setpoint or Feedforward	Feedback						
	J1-1 & 2	J1-4 & 5	5V EXB <sup>1</sup>	10V EXB <sup>1</sup>	4-20mA EXB <sup>1</sup>	3-15 PSI EXB <sup>2</sup>	DC Tach EXB <sup>3</sup>
J1-1 & 2							
J1-4 & 5							
5V EXB <sup>1</sup>							
10V EXB <sup>1</sup>							
4-20mA EXB <sup>1</sup>							
3-15 PSI EXB <sup>2</sup>							
DC Tach EXB <sup>3</sup>							
EXB PULSE FOL <sup>4</sup> <sup>5</sup>							
Serial EXB <sup>5</sup> <sup>6</sup>							

- <sup>1</sup> Requires expansion board EXB007A01 (High Resolution Analog I/O EXB).
  - <sup>2</sup> Requires expansion board EXB004A01 (4 Output Relays/3-15 PSI Pneumatic Interface EXB).
  - <sup>3</sup> Requires expansion board EXB006A01 (DC Tachometer Interface EXB).
  - <sup>4</sup> Requires expansion board EXB005A01 (Master Pulse Reference/Isolated Pulse Follower EXB).
  - <sup>5</sup> Used for Feedforward only. Must not be used for Setpoint Source or Feedback.
  - <sup>6</sup> Requires expansion board EXB001A01 (RS232 Serial Communication EXB). or Requires expansion board EXB002A01 (RS422/RS485 High Speed Serial Communication EXB). or Requires expansion board EXB012A01 (RS232/RS485 Serial Communication EXB).
- Conflicting inputs. Do not use same input signal multiple times.  
 Conflicting level 1 or 2 expansion boards. Do not use!

## Electronic Pot 2 Wire Operating Mode

Provides speed Increase and Decrease inputs to allow EPOT operation with 2 wire inputs. The opto inputs can be switches as shown in Figure 3-24 or logic signals from another device. The values of the preset speeds are set in the Level 1 Preset Speeds block, Preset Speed #1 or Preset Speed #2.

**Figure 3-24 EPOT, 2 Wire Control Connection Diagram**

- J1-8 CLOSED allows normal operation.  
OPEN disables the control and motor coasts to a stop.
- J1-9 CLOSED starts motor operation in the Forward direction.  
OPEN motor decels to stop (depending on Keypad Stop mode).
- J1-10 CLOSED starts motor operation in the Reverse direction.  
OPEN motor decels to stop (depending on Keypad Stop mode).
- Note: Closing both J1-9 and J1-10 at the same time will reset a fault condition.
- J1-11 Selects preset speeds as defined in the Speed Select Table (Table 3-16).
- J1-12 Selects preset speeds as defined in the Speed Select Table (Table 3-16).
- J1-13 CLOSED selects ACC / DEC / S-CURVE group 2.  
OPEN selects ACC / DEC / S-CURVE group 1.
- J1-14 Momentary CLOSED increases motor speed while contact is closed.
- J1-15 Momentary CLOSED decreases motor speed while contact is closed.
- J1-16 If J1-16 is connected, you must set Level 2 Protection block, External Trip to "ON" to activate the opto input.  
CLOSED allows normal operation.  
OPEN causes an external trip to be received by the control. The control will disable and display external trip. When this occurs, the motor stop command is issued, drive operation is terminated and an external trip fault is displayed on the keypad display (also logged into the fault log).

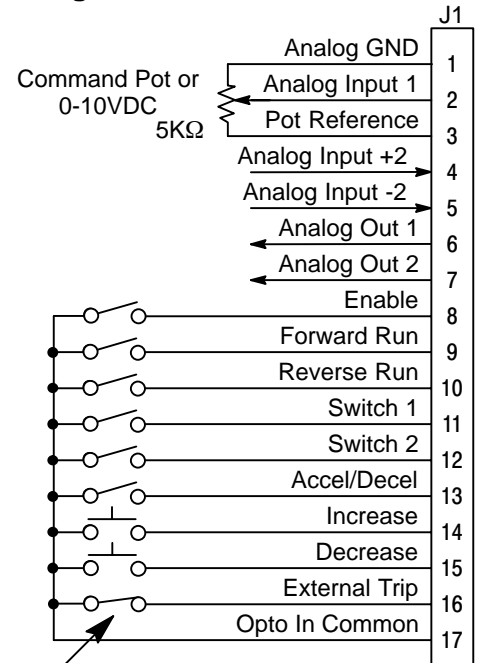

Refer to Figure 3-26.

See recommended terminal tightening torques in Section 7.

**Table 3-16 Speed Select Table**

J1-11	J1-12	Function
OPEN	OPEN	Electronic Pot
CLOSED	OPEN	Command Select *
OPEN	CLOSED	Preset #1
CLOSED	CLOSED	Preset #2

\* Command Select refers to the Level 1 Command Select parameter.

## Electronic Pot 3 Wire Control Mode

Provides speed Increase and Decrease inputs to allow EPOT operation with 3 wire inputs. The opto inputs can be switches as shown in Figure 3-25 or logic signals from another device.

**Figure 3-25 EPOT, 3 Wire Control Connection Diagram**

- J1-8 CLOSED allows normal operation.  
OPEN disables the control and motor coasts to a stop.
- J1-9 Momentary CLOSED starts motor operation in the Forward direction.
- J1-10 Momentary CLOSED starts motor operation in the Reverse direction.  
Note: Closing both J1-9 and J1-10 at the same time will reset a fault condition.
- J1-11 Momentary OPEN motor decels to stop (depending on Keypad Stop mode).
- J1-12 CLOSED selects Level 1 Command Select parameter value.  
OPEN selects EPOT.
- J1-13 CLOSED selects ACC / DEC / S-CURVE group 2.  
OPEN selects ACC / DEC / S-CURVE group 1.
- J1-14 Momentary CLOSED increases motor speed while contact is closed.
- J1-15 Momentary CLOSED decreases motor speed while contact is closed.
- J1-16 If J1-16 is connected, you must set Level 2 Protection block, External Trip to "ON" to activate the opto input.  
CLOSED allows normal operation.  
OPEN causes an external trip to be received by the control. The control will disable and display external trip. When this occurs, the motor stop command is issued, drive operation is terminated and an external trip fault is displayed on the keypad display (also logged into the fault log).

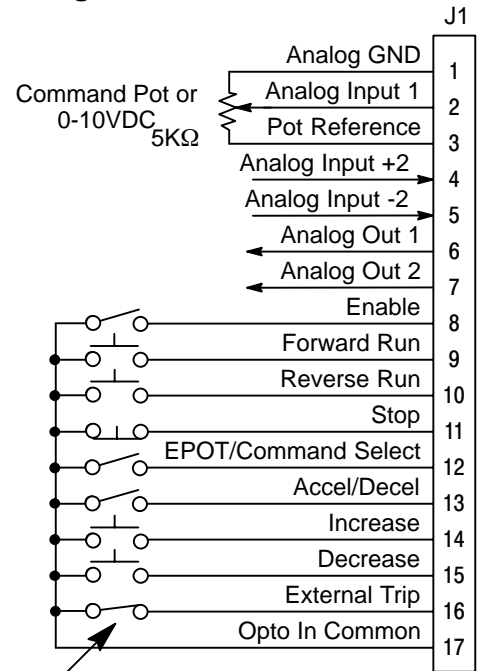

Refer to Figure 3-26.

See recommended terminal tightening torques in Section 7.

## External Trip Input

To activate the External Trip input, the External Trip parameter in the programming Protection Block must be set to "ON".

Terminal J1-16 is available for connection to a normally closed thermostat or overload relay in all operating modes as shown in Figure 3-26. The thermostat or overload relay should be a dry contact type with no power available from the contact. If the motor thermostat or overload relay activates the control will automatically shut down and give an External Trip fault.

Connect the External Trip Input wires to J1-16 and J1-17. Do not place these wires in the same conduit as the motor power leads.

**Figure 3-26 Motor Temperature Relay**

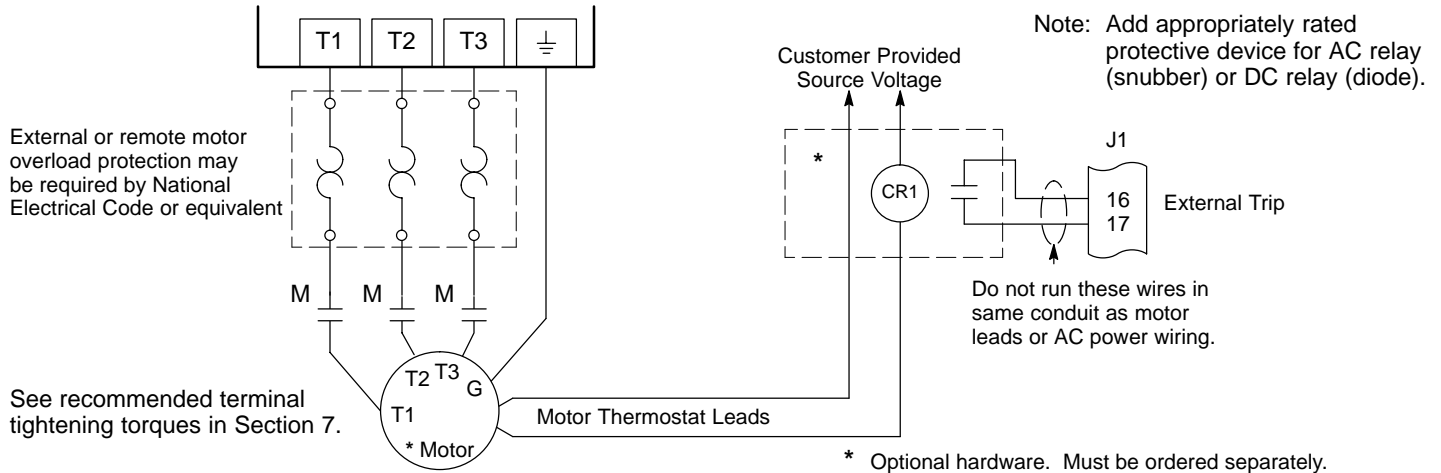

## Opto-Isolated Inputs

The equivalent circuit for the nine Opto inputs is shown in Figure 3-27. The function of each input depends on the operating mode selected and are described previously in this section. This Figure also shows the connections using the internal opto input Supply.

**Figure 3-27 Opto-Input Equivalent Circuit (Using Internal Supply)**

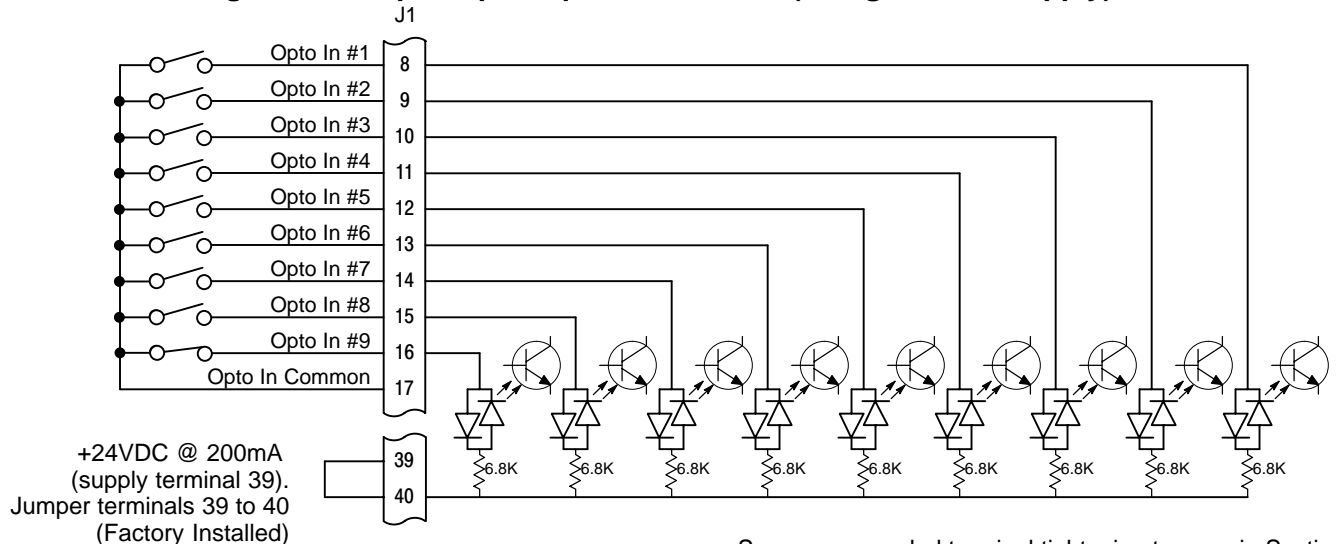

**Figure 3-28 Opto-Input Equivalent Circuit (Using External Supply)**

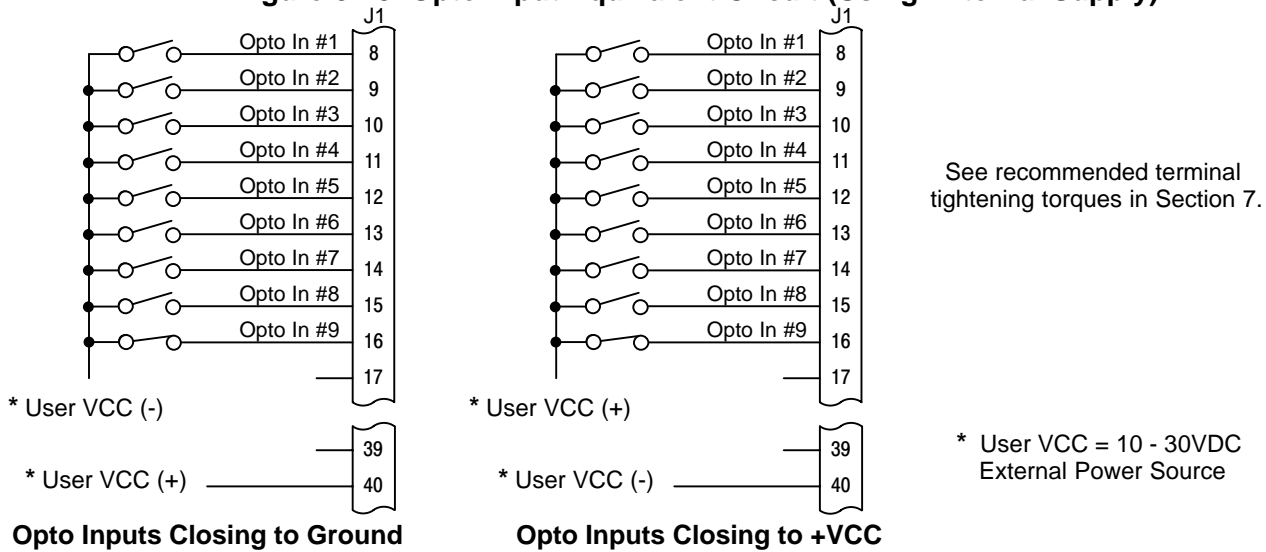

**Opto-Isolated Outputs**

Four programmable Opto-isolated outputs are available at terminals J1-19 through J1-22. See Figure 3-29. Each output may be programmed to represent one output condition. The output conditions are defined in Table 4-4 of Section 4 of this manual. The Opto-isolated outputs may be configured for sinking or sourcing 50 mA each. However, all must be configured the same. The maximum voltage from opto output to common when active is 1.0 VDC (TTL compatible). The Opto-isolated outputs may be connected in different ways as shown in Figure 3-29. The equivalent circuit for the Opto-isolated outputs is shown in Figure 3-30. If the opto outputs are used to directly drive a relay, a flyback diode rated at 1A, 100 V (IN4002) minimum should be connected across the relay coil. See Electrical Noise Considerations in Section 5 of this manual. Each Opto Output is programmed in the Output programming block.

**Figure 3-29 Opto-isolated Output Configurations**

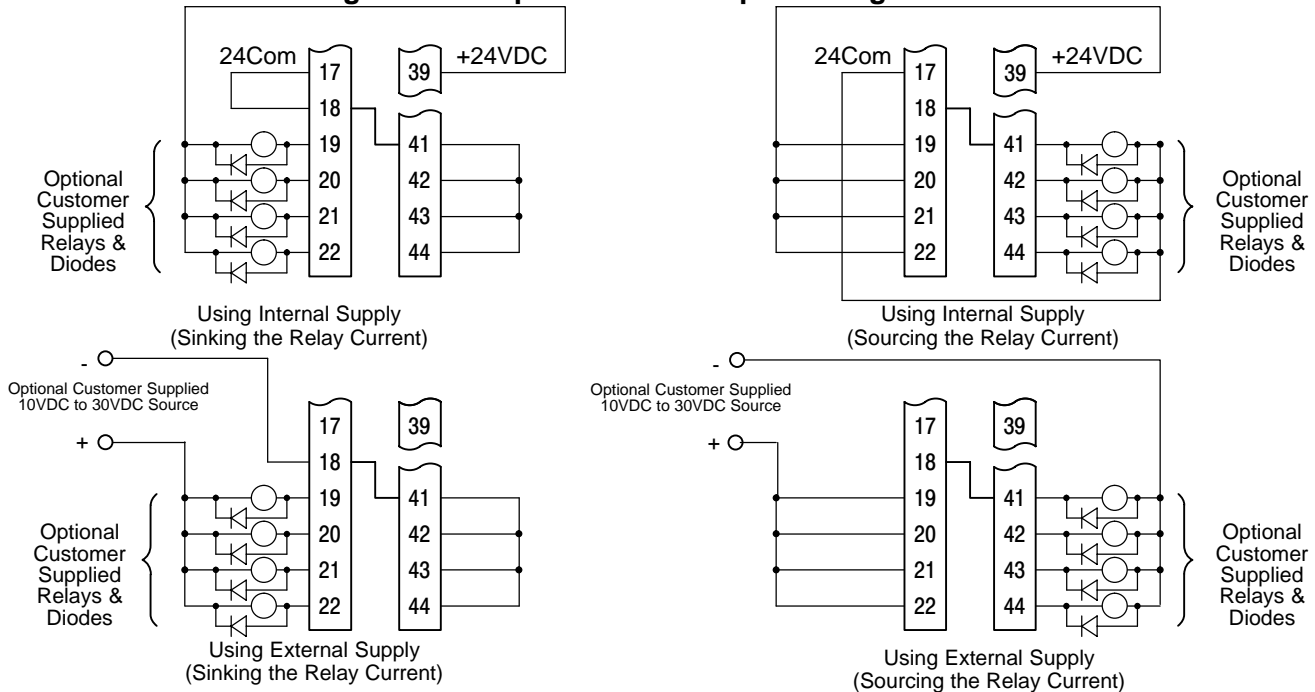

See recommended terminal tightening torques in Section 7.

**Figure 3-30 Opto-Output Equivalent Circuit**

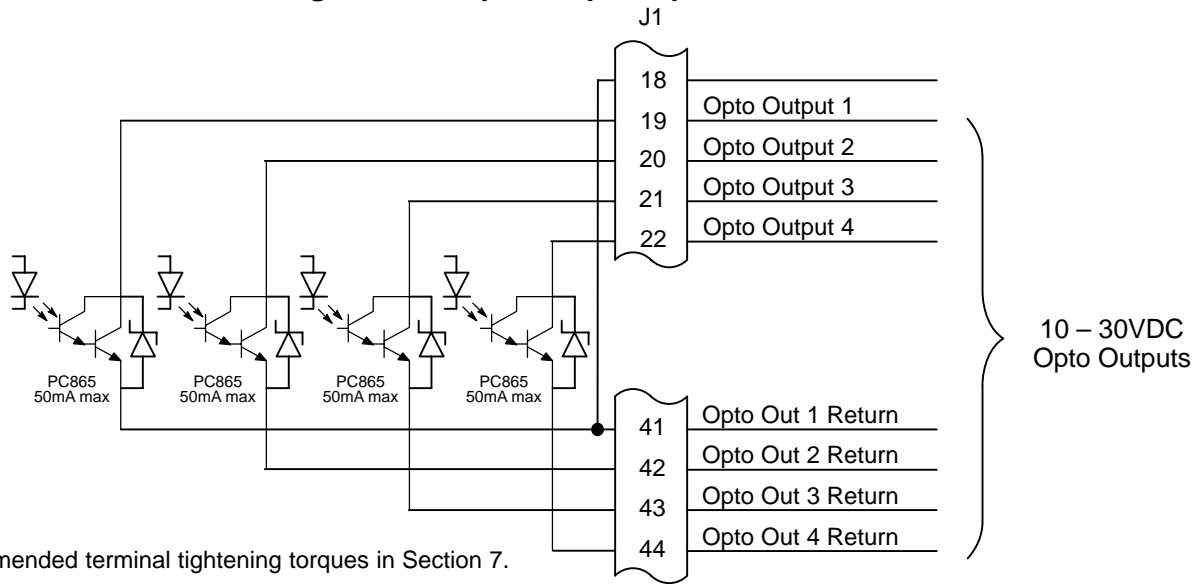

See recommended terminal tightening torques in Section 7.

**Pre-Operation Checklist**

Check of Electrical Items

**⚠ CAUTION:** After completing the installation but before you apply power, be sure to check the following items.

1. Verify AC line voltage at source matches control rating.
2. Inspect all power connections for accuracy, workmanship and tightness and compliance to codes.
3. Verify control and motor are grounded to each other and the control is connected to earth ground.
4. Check all signal wiring for accuracy.
5. Be certain all brake coils, contactors and relay coils have noise suppression. This should be an R-C filter for AC coils and reverse polarity diodes for DC coils. MOV type transient suppression is not adequate.

**⚠ WARNING:** Make sure that unexpected operation of the motor shaft during start up will not cause injury to personnel or damage to equipment.

**Check of Motor and Coupling**

1. Verify freedom of motion of motor shaft.
2. Verify that motor coupling is tight without backlash.
3. Verify the holding brakes if any, are properly adjusted to fully release and set to the desired torque value.

---

## **Power-Up Procedure**

This procedure will help get your system up and running in the Keypad mode quickly. This will allow you to prove the motor and control operation. This procedure assumes that the control and motor are correctly installed (see Section 3 for procedures) and that you have an understanding of the keypad programming & operation procedures. It is not necessary to wire the terminal strip to operate the motor in the Keypad mode.

### **Initial Conditions**

Be sure the control and motor are wired according to the procedures described previously in this manual. Become familiar with the keypad programming and keypad operation of the control as described in Section 4 of this manual.

1. Disconnect the load (including coupling or inertia wheels) from the motor shaft if possible.
2. Verify that all enable inputs to J1-8 are open.
3. Turn power on. Be sure no errors are displayed.
4. Set the Level 1 Input block, Operating Mode parameter to "KEYPAD".
5. Set the Level 2 Output Limits block, "OPERATING ZONE" parameter as desired (STD CONST TQ, STD VAR TQ, QUIET CONST TQ or QUIET VAR TQ).
6. Enter the following motor data in the Level 2 Motor Data block parameters:  
Motor Voltage (Nameplate, VOLTS)  
Motor Rated Amps (Nameplate, FLA)  
Motor Rated Speed (Nameplate, RPM)  
Motor Rated Frequency (Nameplate, HZ)  
Motor Mag Amps (Nameplate, NLA)  
Encoder Counts
7. At the Level 2 Motor Data, go to CALC Presets and select YES (using the up arrow key). Press ENTER and let the control calculate the preset values for the parameters that are required for control operation.
8. Disconnect the motor from the load (including coupling or inertia wheels). If the load can not be disconnected, refer to Section 6 and manually tune the control. After manual tuning, perform steps 10, 11, 15, 16 and 17.

**⚠ WARNING: The motor shaft will rotate during this procedure. Be certain that unexpected motor shaft movement will not cause injury to personnel or damage to equipment.**

9. At the Level 2 Autotune block, perform the following tests:  
CMD OFFSET TRIM  
CUR LOOP COMP  
STATOR R1  
FLUX CUR SETTING  
ENCODER TESTS  
SLIP FREQ TEST
10. Set the Level 2 Output Limits block, "MIN OUTPUT SPEED" parameter.
11. Set the Level 2 Output Limits block, "MAX OUTPUT SPEED" parameter.
12. Remove all power from the control.
13. Couple the motor to its load.
14. Turn power on. Be sure no errors are displayed.
15. Go to Level 2 Autotune block, and perform the SPD CNTRLR CALC test.
16. Run the drive from the keypad using one of the following: the arrow keys for direct speed control, keypad entered speed or the JOG mode.
17. Select and program additional parameters to suit your application.

The control is now ready for use in keypad mode. If a different operating mode is desired, refer to Section 3 for control connection diagrams and Section 4 Programming and Operation.

## Section 4

# Programming and Operation

---

### Overview

The Series 22H Vector Line Regen Control has two control boards installed. The “Converter Control Board” is used to rectify and process the incoming power. The “Inverter Control Board” provides the inverting and power output functions. Each control board has its own J1 terminal strip.

The Inverter Control Board normally has the keypad connected to it. The J1 terminal strip of the Inverter Board provides the user interface for most external connections and software parameters. The Inverter Control board is mounted above the Converter Control Board.

The Converter Control Board is programmed at the factory and should not require program changes. However, you can change the values of several parameters within the firmware (refer to parameters in Appendix B). The J1 terminal strip of the Converter Control Board is factory wired for normal operation.

The keypad must be plugged into the Converter Control Board to change parameter values, or access the fault log or the diagnostic information of the Converter Control Board. A sheet metal panel separates the two control boards and there is a small access hole the the sheet metal panel to attach the keypad to the Converter Control Board. To attach the keypad to the Converter control board, use the following procedure:

#### **Keypad Installation in the Converter Control Board**

1. Be sure all power is disconnected from the Series 22H Control. Wait at least 5 minutes for the bus capacitors to discharge before you proceed.
2. Open the Series 22H cover.
3. Remove the keypad from the Inverter Control Board (secured by 4 screws).
4. Remove the extension ribbon cable from its retaining strap (secured to the sheet metal panel).
5. Connect one end of the ribbon cable into the keypad connector in the Converter Control Board (through the access hole in the sheet metal panel).
6. Connect the other end of the ribbon cable to the keypad.

The control can now be powered up and the Converter Control Board can be programmed or the fault log may be examined. To restore the keypad as factory installed, use the following procedure:

#### **Keypad Installation in the Inverter Control Board**

1. Be sure all power is disconnected from the Series 22H Control. Wait at least 5 minutes for the bus capacitors to discharge before you proceed.
2. Remove the keypad from the ribbon cable and remove the ribbon cable from the keypad connector in the Converter Control Board.
3. Store the extension ribbon cable in its retaining strap (secured to the sheet metal panel).
4. Install the keypad on Inverter Control Board (secured by 4 screws).
5. Close and secure the Series 22H cover.



## Baldor Keypad

The keypad is used to program the control parameters, operate the motor and monitor the status and outputs of the control by accessing the display options, diagnostic menus and the fault log.

**Figure 4-1 Keypad**

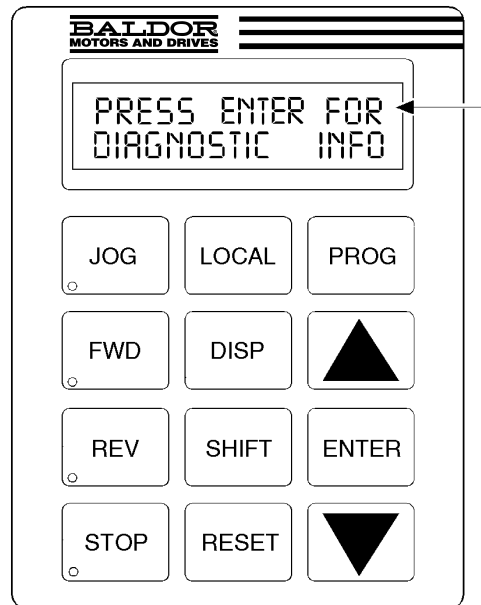
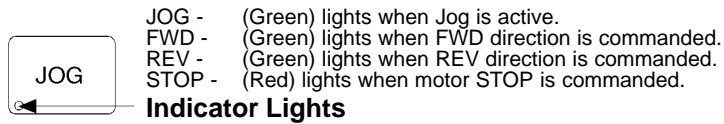

**Keypad Display** - Displays status information during Local or Remote operation. It also displays information during parameter setup and fault or Diagnostic Information.

**PROG** - Press PROG to enter the program mode. While in the Program mode the PROG key is used to edit a parameter setting.

**▲** - (UP Arrow).

Press ▲ to change the value of the parameter being displayed. Pressing ▲ increments the value to the next greater value. Also, when the fault log or parameter list is displayed, the ▲ key will scroll upward through the list. In the local mode pressing the ▲ key will increase motor speed to the next greater value.

**ENTER** - Press ENTER to save parameter value changes and move back to the previous level in the programming menu. In the Display mode the ENTER key is used to directly set the local speed reference. It is also used to select other operations when prompted by the keypad display.

**▼** - (Down Arrow)

Press ▼ to change the value of the parameter being displayed. Pressing ▼ decrements the value to the next lesser value. Also, when the fault log or parameter list is displayed, the ▼ key will scroll downward through the list. In the local mode pressing the ▼ key will decrease motor speed to the next lower value.

**JOG** - Press JOG to select the preprogrammed jog speed. After the JOG key has been pressed, use the FWD or REV keys to run the motor in the direction that is needed. The JOG key is only active in the Local mode.

**FWD** - Press FWD to initiate forward rotation of the motor. This key is only active in the Keypad or Local mode.

**REV** - Press REV to initiate reverse rotation of the motor. This key is active only in the Keypad or Local mode.

**STOP** - Press STOP one time to initiate a stop sequence. Depending on the setup of the control, the motor will either ramp or coast to a stop. This key is operational in all modes of operation unless it has been disabled by the Keypad Stop parameter in the Keypad (programming) Setup Block. Press STOP twice to disable control (coast to stop).

**LOCAL** - Press LOCAL to change between the local (keypad) and remote operation. When the control is in the local mode all other external commands to the J1 terminal strip will be ignored with the exception of the external trip input.

**DISP** - Press DISP to return to Display mode from Programming mode. Provides operational status and advances to the next display menu item including the diagnostic screens.

**SHIFT** - Press SHIFT in the program mode to control cursor movement. Pressing the SHIFT key once moves the blinking cursor one character position to the right. While in Program mode, a parameter value may be reset to the factory preset value by pressing the SHIFT key until the arrow symbols at the far left of the keypad display are flashing, then press an arrow key. In the Display mode the SHIFT key is used to adjust the keypad contrast.

**RESET** - Press RESET to clear all fault messages (in local mode). Can also be used to return to the top of the block programming menu without saving any parameter value changes.

## Display Mode

The control is in the DISPLAY MODE at all times except when parameter values are changed (Programming mode). The Keypad Display shows the status of the control as in the following example.



The DISPLAY MODE is used to view operating status, Diagnostic INFO and the Fault Log. The description of how to do these tasks are described on the following pages.

**Adjusting Display Contrast** When AC power is applied to the control, the keypad should display the status of the control. If there is no visible display, use the following procedure to adjust the contrast of the display.

(Contrast may be adjusted in display mode when motor is stopped or running)

Action	Description	Display	Comments
Apply Power	No visible display		
Press DISP Key	Places control in display mode		
Press SHIFT SHIFT	Allows display contrast adjustment		
Press ▲ or ▼ Key	Adjusts display intensity	ADJUST CONTRAST ⬇ (ENTER) TO SAVE	
Press ENTER	Saves level of contrast and exits to display mode	STOP MOTOR SPEED LOCAL            0 RPM	Typical display

## Display Mode Screens

Action	Description	Display	Comments
Apply Power		BALDOR MOTORS & DRIVES	Logo display for 5 seconds.
	Display mode showing motor speed.	STOP MOTOR SPEED LOCAL            0 RPM	No faults present. Local keypad mode. If in remote/serial mode, press local for this display.
Press DISP key	Display mode showing custom unit output rate.	STOP OUTPUT RATE LOCAL            0 XXXX	Output rate display will only appear if Value At Speed parameter is entered.
Press DISP key	Display Frequency	STOP FREQUENCY LOCAL            0.00 HZ	
Press DISP key	Display Current	STOP CURRENT OUT LOCAL            0.00 A	
Press DISP key	Display Voltage	STOP VOLTAGE OUT LOCAL            0 V	
Press DISP key	Combined Display	STOP 0V 0 RPM LOC 0.0A 0.0 HZ	
Press DISP key	Screen to enter Fault Log	PRESS ENTER FOR FAULT LOG	
Press DISP key	Screen to enter Diagnostic Menu	PRESS ENTER FOR DIAGNOSTIC INFO	
Press DISP key	Exit Display mode and return to Motor Speed display	STOP MOTOR SPEED LOCAL            0 RPM	

Display Mode Continued





Display Screens & Diagnostic Information Access

Action	Description	Display	Comments
Apply Power		BALDOR MOTORS & DRIVES	Logo display for 5 seconds.
	Display mode showing motor speed.	STOP MOTOR SPEED LOCAL 0 RPM	No faults present. Local keypad mode. If in remote/serial mode, press local for this display.
Press DISP key 6 times	Scroll to Diagnostic Information screen	PRESS ENTER FOR DIAGNOSTIC INFO	Diagnostic Access screen.
Press ENTER key	Access diagnostic information.	STOP SPEED REF LOCAL 0 RPM	First Diagnostic Information screen.
Press DISP key	Display mode showing control temperature.	STOP CONTROL TEMP LOCAL 0.0° C	
Press DISP key	Display mode showing bus voltage.	STOP BUS VOLTAGE LOCAL XXXV	
Press DISP key	Display mode showing % overload current remaining.	STOP OVRD LEFT LOCAL 100.00%	
Press DISP key	Display mode showing opto inputs & outputs states. 0=OPEN, 1=CLOSED.	DIGITAL I/O 00000000 0000	Opto Inputs states (Left); Opto Outputs states (Right).
Press DISP key	Display mode showing actual drive running time.	TIME FROM PUR UP 0000000.01.43	HR.MIN.SEC format.
Press DISP key	Display mode showing operating zone, voltage and control type.	QUIET VAR TQ XXXV FLUX VECTOR	Typical display.
Press DISP key	Display mode showing continuous amps; PK amps rating; amps/volt scale of feedback, power base ID.	XXA XX APK X.XX A/V ID:XXX	ID is displayed as a hexadecimal value.
Press DISP key	Display mode showing which Group1 or 2 expansion boards are installed and recognized.	G1 NOT INSTALLED G2 NOT INSTALLED	
Press DISP key	Display mode showing motor shaft revolutions from the REV home set point.	POSITION COUNTER + 000.00000 REV	
Press DISP key	Display mode showing parameter table selected.	STOP TABLE LOCAL 0	
Press DISP key	Display mode showing software version and revision installed in the control.	SOFTWARE VERSION SXX-X.XX	
Press DISP key	Displays exit choice.	PRESS ENTER FOR DIAGNOSTIC EXIT	Press ENTER to exit diagnostic information.

**Display Mode** Continued

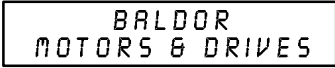
**Fault Log Access**

When a fault condition occurs, motor operation stops and a fault code is displayed on the Keypad display. The control keeps a log of up to the last 31 faults. If more than 31 faults have occurred the oldest fault will be deleted from the fault log to make room for the newest fault. To access the fault log perform the following procedure:

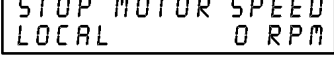
Action	Description	Display	Comments
Apply Power			Logo display for 5 seconds.
	Display mode showing motor speed.		Display mode.
Press DISP key 5 times	Scroll to the Fault Log screen		Fault Log access screen.
Press ENTER key	Display first fault type and time fault occurred.		1=Most recent fault displayed. 2=Second most recent fault, etc.
Press ▲ key	Scroll through fault messages.		If no messages, the fault log exit choice is displayed.
Press ENTER key	Return to display mode.		Display mode stop key LED is on.

## Program Mode

The Program Mode is used to:

1. Enter motor data.
2. CALC Presets and Autotune the drive.
3. Customize the drive (Control and Motor) parameters to your application.

From the Display Mode press the PROG key to access the Program Mode.

Note: When a parameter is selected, alternately pressing the Disp and Prog keys will toggle between the Display Mode and the selected parameter. When a parameter is selected for programming, the keypad display gives you the following information:

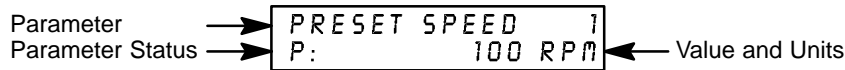

**Parameter Status.** All programmable parameters are displayed with a “P:” in the lower left corner of the keypad display. If a parameter is displayed with a “V:”, the parameter value may be viewed but not changed while the control is enabled. If the parameter is displayed with an “L:”, the value is locked and the security access code must be entered before its’ value can be changed.

## Parameter Blocks Access for Programming

Use the following procedure to access parameter blocks to program the control.





Action	Description	Display	Comments
Apply Power	Keypad Display shows this opening message.	<pre>BALDOR MOTORS &amp; DRIVES</pre>	Logo display for 5 seconds.
	If no faults and programmed for LOCAL operation.	<pre>STOP MOTOR SPEED LOCAL 0 RPM</pre>	Display mode.
	If no faults and programmed for REMOTE operation.	<pre>STOP MOTOR SPEED REMOTE 0 RPM</pre>	If fault is displayed, refer to the Troubleshooting section of this manual.
Press PROG key		<pre>PRESS ENTER FOR PRESET SPEEDS</pre>	Press ENTER to access Preset Speed parameters.
Press ▲ or ▼ key	Scroll to the ACCEL/DECEL block.	<pre>PRESS ENTER FOR ACCEL/DECEL RATE</pre>	Press ENTER to access Accel and Decel rate parameters.
Press ▲ or ▼ key	Scroll to the Level 2 Block.	<pre>PRESS ENTER FOR LEVEL 2 BLOCKS</pre>	Press ENTER to access Level 2 Blocks.
Press ENTER key	First Level 2 block display.	<pre>PRESS ENTER FOR OUTPUT LIMITS</pre>	
Press ▲ or ▼ key	Scroll to Programming Exit menu.	<pre>PRESS ENTER FOR PROGRAMMING EXIT</pre>	Press ENTER to return to Display mode.
Press ENTER key	Return to display mode.	<pre>STOP MOTOR SPEED LOCAL 0 RPM</pre>	

**Program Mode** Continued

**Changing Parameter Values when Security Code Not Used**

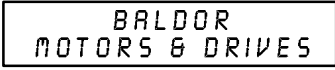
Use the following procedure to program or change a parameter already programmed into the control when a security code is not being used.

The example shown changes the operating mode from Keypad to Bipolar.

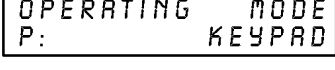
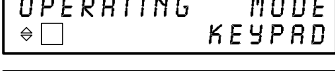
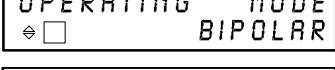
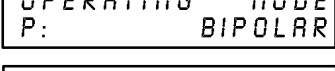
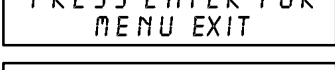
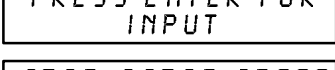
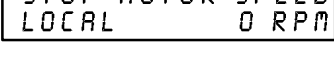
Action	Description	Display	Comments
Apply Power	Keypad Display shows this opening message.		Logo display for 5 seconds.
	If no faults and programmed for LOCAL operation.		Display mode. Stop LED on.
Press PROG key	Access programming mode.		
Press ▲ or ▼ key	Scroll to Level 1 Input Block.		Press ENTER to access INPUT block parameter.
Press ENTER key	Access Input Block.		Keypad mode shown is the factory setting.
Press ENTER key	Access Operating Mode parameter.		Keypad mode shown is the factory setting.
Press ▲ key	Scroll to change selection.		At flashing cursor, select desired mode, BIPOLAR in this case.
Press ENTER	Save selection to memory.		Press ENTER to save selection.
Press ▲ key	Scroll to menu exit.		
Press ENTER key	Return to Input Block.		
Press DISP key	Return to Display Mode.		Typical display mode.

**Program Mode** Continued

**Reset Parameters to Factory Settings**

Sometimes it is necessary to restore the parameter values to the factory settings. Follow this procedure to do so. Be sure to change the Level 2 Motor Data block "Motor Rated Amps" to the correct value after this procedure (restored factory setting is 999).

Note: All specific application parameters already programmed will be lost when resetting the control to factory settings.

Note: After factory settings are restored, the drive must be re-tuned.

Action	Description	Display	Comments
Apply Power	Keypad Display shows this opening message.	<pre>BALDOR MOTORS &amp; DRIVES</pre>	Logo display for 5 seconds.
	If no faults and programmed for LOCAL operation.	<pre>STOP MOTOR SPEED LOCAL          0 RPM</pre>	Display mode. Stop LED on.
Press PROG key	Enter program mode.	<pre>PRESS ENTER FOR PRESET   SPEEDS</pre>	
Press ▲ or ▼ key	Scroll to Level 2 Blocks.	<pre>PRESS ENTER FOR LEVEL 2   BLOCKS</pre>	
Press ENTER key	Select Level 2 Blocks.	<pre>PRESS ENTER FOR OUTPUT LIMITS</pre>	
Press ▲ or ▼ key	Scroll to the Miscellaneous block.	<pre>PRESS ENTER FOR MISCELLANEOUS</pre>	
Press ENTER key	Select Miscellaneous block.	<pre>RESTART AUTO/MAN P:          MANUAL</pre>	
Press ▲ key	Scroll to Factory Settings parameter.	<pre>FACTORY SETTINGS P:          NO</pre>	
Press ENTER key	Access Factory Settings parameter.	<pre>FACTORY SETTINGS ⬆️□          NO</pre>	<input type="checkbox"/> represents blinking cursor.
Press ▲ key	Scroll to YES, to choose original factory settings.	<pre>FACTORY SETTINGS ⬆️□          YES</pre>	
Press ENTER key	Restores factory settings.	<pre>FACTORY SETTINGS P:LOADING PRESETS</pre>	"Loading Presets" is first message "Operation Done" is next "No" is displayed last.
Press ▲ key	Scroll to menu exit.	<pre>PRESS ENTER FOR MENU EXIT</pre>	
Press ENTER key	Return to Level 1 blocks.	<pre>PRESS ENTER FOR LEVEL 2   BLOCKS</pre>	Exit Level 2 blocks.
Press ▲ or ▼ key	Scroll to Programming exit.	<pre>PRESS ENTER FOR PROGRAMMING EXIT</pre>	Exit Programming mode and return to Display mode.
Press ENTER key	Return to display mode.	<pre>STOP MOTOR SPEED LOCAL          0 RPM</pre>	Display mode. Stop LED on.

**Program Mode** Continued

**Initialize New Firmware**

After new firmware is installed, the control must be initialized to the new firmware version and memory locations. Use the following procedure to Initialize the firmware.

Action	Description	Display	Comments
Apply Power	Keypad Display shows this opening message.	<pre>BALDOR MOTORS &amp; DRIVES</pre>	Logo display for 5 seconds.
	If no faults and programmed for LOCAL operation.	<pre>STOP MOTOR SPEED LOCAL          0 RPM</pre>	Display mode. Stop LED on.
Press PROG key	Enter program mode.	<pre>PRESS ENTER FOR PRESET     SPEEDS</pre>	
Press ▲ or ▼ key	Scroll to Level 2 Blocks.	<pre>PRESS ENTER FOR LEVEL 2    BLOCKS</pre>	
Press ENTER key	Select Level 2 Blocks.	<pre>PRESS ENTER FOR OUTPUT LIMITS</pre>	
Press ▲ or ▼ key	Scroll to the Miscellaneous block.	<pre>PRESS ENTER FOR MISCELLANEOUS</pre>	
Press ENTER key	Select Miscellaneous block.	<pre>RESTART AUTO/MAN P:          MANUAL</pre>	
Press ▲ key	Scroll to Factory Settings parameter.	<pre>FACTORY SETTINGS P:          NO</pre>	
Press ENTER key	Access Factory Settings parameter.	<pre>FACTORY SETTINGS ◄ □          NO</pre>	□ represents blinking cursor.
Press ▲ key	Scroll to YES, to choose original factory settings.	<pre>FACTORY SETTINGS ◄ □          YES</pre>	
Press ENTER key	Restores factory settings.	<pre>FACTORY SETTINGS P:LOADING PRESETS</pre>	"Loading Presets" is first message "Operation Done" is next "No" is displayed last.
Press ▲ key	Scroll to menu exit.	<pre>PRESS ENTER FOR MENU EXIT</pre>	
Press ENTER key	Return to display mode.	<pre>STOP MOTOR SPEED LOCAL          0 RPM</pre>	Display mode. Stop LED on.
Press DISP key several times	Scroll to diagnostic information screen.	<pre>PRESS ENTER FOR DIAGNOSTIC INFO</pre>	If you wish to verify the software version, enter diagnostic info.
Press ENTER key	Access diagnostic information.	<pre>STOP SPEED   REF LOCAL        0 RPM</pre>	Displays commanded speed, direction of rotation, Local/Remote and motor speed.
Press DISP key	Display mode showing software version and revision installed in the control.	<pre>SOFTWARE VERSION XXX-X.XX</pre>	Verify new firmware version.
Press DISP key	Displays exit choice.	<pre>PRESS ENTER FOR DIAGNOSTIC EXIT</pre>	Press ENTER to exit diagnostic information.



---

## **Parameter Definitions**

### **Converter Control Board Parameters**

Converter section parameters are programmed at the factory. Table 4-1 is a list of the parameters that can be changed. However, to make any parameter adjustments the keypad must be installed in the Converter Control Board as described previously in this section. Each Converter section parameter is defined in Table 4-2.

**Table 4-1 Converter Section Parameter List**

<b>LEVEL 1 BLOCKS</b>
<b>Miscellaneous</b>
Factory Settings
Line Inductor
Bus Capacitance
DAC Selection
<b>Security Control</b>
Security State
Access Timeout
Access Code

**Table 4-2 Converter Control Board Parameter Definitions**

Block Title	Parameter	Description
MISC	Factory Settings	Restores factory settings for converter section parameters. Select YES and press ENTER to restore factory parameter values. The Keypad Display will show "Operation Done" then return to "NO" when complete.
	Line Inductor (Boost Regulator)	The value of the internal or external boost regulator inductor in "mH". This parameter sets the current loop gain of the converter section. This value is factory set and should not require adjustment.
	Bus Capacitance	Sets the nominal DC Bus capacitance. This parameter sets the voltage loop gain for the converter section. This value is factory set and should not require adjustment unless more capacitance or more controls are added across the DC Bus.
	DAC Selection	This parameter configures both Analog Outputs #1 (J1-6) and #2 (J1-7) at the same time for troubleshooting purposes. AB BC Cross- This selection provides a scaled 0-5VDC signals at Outputs #1 and #2. Analog Output #1 represents the Line-Line voltage (L1-L2). Analog Output #2 represents the Line-Line voltage (L2-L3). DQ CONTRLR- This selection provides a scaled 0-5VDC signals at Outputs #1 and #2. Analog Output #1 represents the Direct Control voltage. Analog Output #2 represents the Quadrature Control voltage. DQ Currents- This selection provides a scaled 0-5VDC signals at Outputs #1 and #2. Analog Output #1 represents the Direct Control current. Analog Output #2 represents the Quadrature Control current. IQ Command- This selection provides a scaled 0-5VDC signals at Outputs #1 and #2. Analog Output #1 represents the Quadrature Command signal. Analog Output #2 represents the Quadrature Feedback signal. IB and IC- This selection provides a scaled 0-5VDC signals at Outputs #1 and #2. Analog Output #1 represents the Phase B current feedback. Analog Output #2 represents the Phase C current feedback. Va and Vb- This selection provides a scaled 0-5VDC signals at Outputs #1 and #2. Analog Output #1 represents the PWM voltage for Phase A. Analog Output #2 represents the PWM voltage for Phase B. Ia and Ib- This selection provides a scaled 0-5VDC signals at Outputs #1 and #2. Analog Output #1 represents Phase A current. Analog Output #2 represents Phase B current.
SECURITY CONTROL	Security State	Off - No security Access Code required to change parameter values. Local - Requires security Access Code to be entered (using the keypad) before parameter changes can be made using the Keypad. Serial - Requires security Access Code to be entered (over the Serial Link) before parameter changes can be made using the Serial Link. Total - Requires security Access Code to be entered (using Keypad or Serial Link) before parameter changes can be made using the Keypad or serial link. Note: If security is set to Local, Serial or Total you can press PROG and scroll through the parameter values and view their values but you are not allowed to change their values unless you enter the correct access code.
	Access Timeout	The time in seconds the security access remains enabled after leaving the programming mode. If you exit and go back into the program Mode within this time limit, the security Access Code does not have to be re-entered. This timer starts when leaving the Program Mode (by pressing DISP). Note: This feature is not available when using the Serial operating mode or if power is cycled.
	Access Code	A 4 digit number code. Only persons that know the code can change secured Level 1 and Level 2 parameter values. Note: Please record your access code and store it in a safe place. If you cannot gain entry into parameter values to change a protected parameter, please contact Baldor. Be prepared to give the 5 digit code shown on the lower right side of the Keypad Display at the Security Control Access Code parameter prompt.

## Inverter Control Board Parameters (Version 3.20)

To make programming easier, parameters have been arranged into the two level structure shown in Table 4-3. Press the PROG key to enter the programming mode and the "Preset Speeds" programming block will be displayed. Use the Up (▲) and Down (▼) arrows to scroll through the parameter blocks. Press ENTER to access parameters within a programming block.

Tables 4-4 and 4-5 provide an explanation of each parameter. A complete Parameter Block Values list is located at the end of this manual. This list defines the programmable range and factory preset value for each parameter. The list has a space to record your settings for future reference.

**Table 4-3 Inverter Section Parameter List**

LEVEL 1 BLOCKS		LEVEL 2 BLOCKS	
<b>Preset Speeds</b>	<b>Input</b>	<b>Output Limits</b>	<b>Motor Data – Continued</b>
Preset Speed #1	Operating Mode	Operating Zone	Resolver Speeds
Preset Speed #2	Command Select	Min Output Speed	CALC Presets
Preset Speed #3	ANA CMD Inverse	Max Output Speed	
Preset Speed #4	ANA CMD Offset	PK Current Limit	<b>Brake Adjust</b>
Preset Speed #5	ANA 2 Deadband	PWM Frequency	Resistor Ohms
Preset Speed #6	ANA1 CUR Limit	CUR Rate Limit	Resistor Watts
Preset Speed #7			DC Brake Current
Preset Speed #8	<b>Output</b>	<b>Custom Units</b>	
Preset Speed #9	Opto Output #1	Decimal Places	<b>Process Control</b>
Preset Speed #10	Opto Output #2	Value at Speed	Process Feedback
Preset Speed #11	Opto Output #3	Units of Measure	Process Inverse
Preset Speed #12	Opto Output #4		Setpoint Source
Preset Speed #13	Zero SPD Set PT	<b>Protection</b>	Setpoint Command
Preset Speed #14	At Speed Band	Overload	Set PT ADJ Limit
Preset Speed #15	Set Speed	External Trip	Process ERR TOL
	Analog Out #1	Local Enable INP	Process PROP Gain
<b>Accel / Decel Rate</b>	Analog Out #2	Following Error	Process INT Gain
Accel Time #1	Analog #1 Scale	Torque Proving	Process DIFF Gain
Decel Time #1	Analog #2 Scale		Follow I:O Ratio
S-Curve #1	Position Band	<b>Miscellaneous</b>	Follow I:O OUT
Accel Time #2		Restart Auto/Man	Master Encoder
Decel Time #2	<b>Vector Control</b>	Restart Fault/Hr	
S-Curve #2	Ctrl Base Speed	Restart Delay	<b>Communications Protocol</b>
	Feedback Filter	Factory Settings	Protocol
<b>Jog Settings</b>	Feedback Align	Homing Speed	Baud Rate
Jog Speed	Current PROP Gain	Homing Offset	Drive Address
Jog Accel Time	Current INT Gain		
Jog Decel Time	Speed PROP Gain	<b>Security Control</b>	<b>Auto-Tuning</b>
Jog S-Curve Time	Speed INT Gain	Security State	CALC Presets
	Speed DIFF Gain	Access Timeout	CMD Offset Trim
<b>Keypad Setup</b>	Position Gain	Access Code	CUR Loop Comp
Keypad Stop Key	Slip Frequency		Flux CUR Setting
Keypad Stop Mode	Stator R1	<b>Motor Data</b>	Feedback Test
Keypad Run Fwd	Stator X1	Motor Voltage	Slip Freq Test
Keypad Run Rev	Prop Gain #1	Motor Rated Amps	SPD CNTRLR CALC
Keypad Jog Fwd	Int Gain #1	Motor Rated SPD	
Keypad Jog Rev		Motor Rated Freq	
Local Hot Start		Motor Mag Amps	
		Encoder Counts	

**Table 4-4 Inverter Control Board Level 1 Parameter Definitions**

Block Title	Parameter	Description
PRESET SPEEDS	Preset Speeds #1 – #15	Allows selection of 15 predefined motor operating speeds. Each speed may be selected using external switches connected to J1-11, J1-12, J1-13 and J1-14 when Operating Mode is set to 15 Speed. For motor operation, a motor direction command must be given along with a preset speed command.
ACCEL/DECEL RATE	Accel Time #1,2 Decel Time #1,2 S-Curve #1,2	<p>Accel time is the number of seconds required for the motor to increase at a linear rate from 0 RPM to the RPM specified in the "Max Output Speed" parameter in the Level 2 Output Limits block.</p> <p>Decel time is the number of seconds required for the motor to decrease at a linear rate from the speed specified in the "Max Output Speed" parameter to 0 RPM.</p> <p>S-Curve is a percentage of the total Accel and Decel time and provides smooth starts and stops. Half of programmed S-Curve % applies to Accel and half to Decel ramps. 0% represents no "S" and 100% represents full "S" with no linear segment.</p> <p>Note: Accel #1, Decel #1 and S-Curve #1 are associated together. Likewise, Accel #2, Decel #2 and S-Curve #2 are associated together. These associations can be used to condition any Preset Speed or External Speed command.</p> <p>Note: If drive faults occur during rapid Accel or Decel, selecting an S-curve may eliminate the faults.</p>
JOG SETTINGS	Jog Speed Jog Accel Time Jog Decel Time Jog S-Curve	<p>Jog Speed is the programmed speed used during for jog. Jog can be initiated from the keypad or terminal strip. At the Keypad, press the JOG key then press and hold the FWD or REV. For Standard Run, close the JOG input (J1-12) then close and maintain the direction input (J1-9 or J1-10).</p> <p>Process Control mode operation is different. If the terminal strip Process Mode Enable input (J1-13) is closed, pressing the Keypad JOG key (or closing J1-14) will cause the drive to move in the direction of the error (without pressing FWD or REV).</p> <p>Jog Accel Time changes the slope of the jog accel ramp. It is the time from zero speed to maximum speed programmed in seconds.</p> <p>Jog Decel Time changes the slope of the jog decel ramp. It is the time from maximum speed to zero speed programmed in seconds.</p> <p>Jog S-Curve changes the S-Curve to a preset value for jog mode.</p>

**Figure 4-2 40% S-Curve Example**

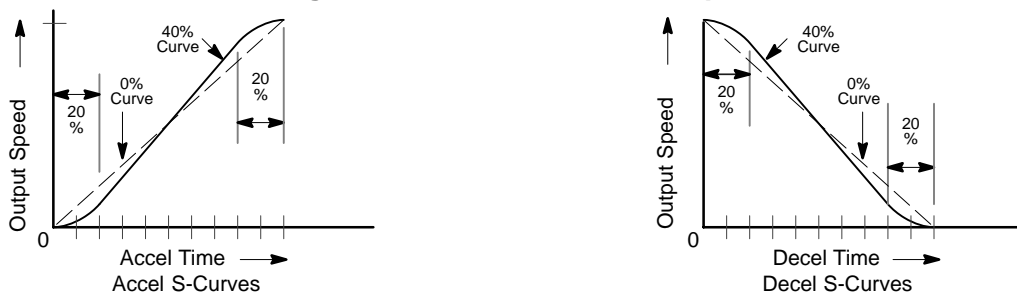

**Table 4-4 Inverter Control Board Level 1 Parameter Definitions - Continued**

Block Title	Parameter	Description
KEYPAD SETUP	Keypad Stop Key	Stop Key - Allows keypad “STOP” key to initiate motor stop during remote or serial operation (if Stop key is set to Remote ON). If active, pressing “STOP” automatically selects Local mode and initiates the stop command.
	Keypad Stop Mode	Stop Mode - Selects if the Stop command causes the motor to “COAST” to a stop or “REGEN” to a stop. In COAST, the motor is turned off and allowed to coast to a stop. In REGEN, the voltage and frequency to the motor is reduced at a rate set by “Decel Time”.
	Keypad Run FWD	Run FWD - ON makes the keypad “FWD” key active in Local mode.
	Keypad Run REV	Run REV - ON makes the keypad “REV” key active in Local mode.
	Keypad Jog FWD	Jog FWD - ON makes the keypad “FWD” key active in Local Jog mode.
	Keypad Jog REV	Jog REV - ON makes the keypad “REV” key active in Local Jog mode.
	Loc. Hot Start	Loc. Hot Start OFF disables the Stop input at J1-11 in the keypad operating mode. ON enables the Stop input at J1-11 in the keypad operating mode.
INPUT	Operating Mode	Ten “Operating Modes” are available. Choices are: Keypad, Standard Run, 15SPD, 3 SPD ANA 2 Wire, 3 SPD ANA 3 Wire, Serial, Bipolar, Process, EPOT 2 Wire and EPOT 3 Wire. External connections to the control are made at the J1 terminal strip (wiring diagrams are shown in Section 3 “Operating Modes”).
	Command Select	Selects the external speed reference to be used. The easiest method of speed control is to select POTENTIOMETER and connect a 5K $\Omega$ pot to J1-1, J1-2, and J1-3. $\pm 5, \pm 10$ VDC or 4-20mA input command can be applied to J1-4 and J1-5.  If long distance is required between the external speed control and the control, the 4-20mA selections at J1-4 and J1-5 should be considered. Current loop allows long cable lengths without attenuation of the command signal.  10 VOLT W/TORQ FF - when a differential command is present at J1-4 and 5, allows additional 5V torque feedforward input at J1-1, 2 and 3 to set a predetermined amount of torque inside the rate loop with high gain settings.  EXB PULSE FOL - selects optional Master Pulse Reference/Isolated Pulse Follower expansion board if installed.  5VOLT EXB - selects optional High Resolution I/O expansion board if installed.  10VOLT EXB - selects optional High Resolution I/O expansion board if installed.  4–20mA EXB – selects the 4–20mA input of the optional High Resolution I/O expansion board if installed.  3-15 PSI EXB selects optional 3-15 PSI expansion board if installed.  Tachometer EXB- selects optional DC Tachometer expansion board if installed.  Serial -selects optional Serial Communications expansion board if installed.  None - Used in Process Control mode, two input configuration with no Feedforward input.  Note: When using the 4-20mA input, the JP1 jumper on the main control board must be moved to pins 2 and 3.
	ANA CMD Inverse	“OFF” will cause a low input voltage (e.g. 0VDC) to be a low motor speed command and a maximum input voltage (e.g. 10VDC) to be a maximum motor speed command. “ON” will cause a low input voltage (e.g. 0VDC) to be a maximum motor speed command and a maximum input voltage (e.g. 10VDC) to be a low motor speed command.
	ANA CMD Offset	Provides an offset to the Analog Input to minimize signal drift. For example, if the minimum speed signal is 1VDC (instead of 0VDC) the ANA CMD Offset can be set to -10% so the minimum voltage input is seen by control as 0VDC.
	ANA 2 Deadband	Allows a defined range of voltage to be a deadband. A command signal within this range will not affect the control output. The deadband value is the voltage above and below the zero command signal level.
	ANA 1 CUR Limit	“OFF” Allows normal control operation. “ON” Allows the 5V input at J1-2 (referenced to J1-1) to be used for reduction of the programmed current limit parameter for torque trimming during operation.

**Table 4-4 Inverter Control Board Level 1 Parameter Definitions - Continued**

Block Title	Parameter	Description																																		
OUTPUT	OPTO OUTPUT #1 – #4	<p>Four optically isolated digital outputs that have two operating states, logical High or Low. Each output may be configured to any of the following conditions:</p> <table border="1"> <thead> <tr> <th data-bbox="667 373 781 401">Condition</th> <th data-bbox="878 373 1008 401">Description</th> </tr> </thead> <tbody> <tr> <td data-bbox="667 407 753 434">Ready -</td> <td data-bbox="878 407 1468 434">Active when power is applied and no faults are present.</td> </tr> <tr> <td data-bbox="667 441 808 468">Zero Speed -</td> <td data-bbox="878 441 1565 495">Active when motor RPM is below the value of the Level 1 Output “Zero SPD Set Pt” parameter.</td> </tr> <tr> <td data-bbox="667 501 781 529">At Speed -</td> <td data-bbox="878 501 1544 556">Active when output speed is within the speed range defined by the Level 1 Output “At Speed Band” parameter.</td> </tr> <tr> <td data-bbox="667 562 824 590">At Set Speed -</td> <td data-bbox="878 562 1511 617">Active when output speed is at or above the Level 1 Output “Set Speed” parameter.</td> </tr> <tr> <td data-bbox="667 623 781 651">Overload -</td> <td data-bbox="878 623 1500 678">Active during an Overload fault caused by a time out when output current is greater than Rated Current.</td> </tr> <tr> <td data-bbox="667 684 846 711">Keypad Control -</td> <td data-bbox="878 684 1370 711">Active when control is in Local keypad control.</td> </tr> <tr> <td data-bbox="667 718 737 745">Fault -</td> <td data-bbox="878 718 1300 745">Active when a fault condition is present.</td> </tr> <tr> <td data-bbox="667 751 841 779">Following ERR -</td> <td data-bbox="878 751 1495 806">Active when the motor speed is outside the user specified tolerance band defined by the At Speed Band parameter.</td> </tr> <tr> <td data-bbox="667 812 846 840">Motor Direction -</td> <td data-bbox="878 812 1565 867">Active High when REV direction feedback is sensed. Active Low when FWD direction feedback is sensed.</td> </tr> <tr> <td data-bbox="667 873 776 900">Drive On -</td> <td data-bbox="878 873 1565 928">Active when control is “Ready” (has reached excitation level and capable of producing torque).</td> </tr> <tr> <td data-bbox="667 934 841 961">CMD Direction -</td> <td data-bbox="878 934 1565 1016">Active when Forward or Reverse is selected or enabled. Logical output state indicates Forward or Reverse direction. High=FWD, Low=REV.</td> </tr> <tr> <td data-bbox="667 1022 802 1050">AT Position -</td> <td data-bbox="878 1022 1539 1077">Active during an internal positioning command when control is within the position band parameter tolerance.</td> </tr> <tr> <td data-bbox="667 1083 862 1110">Over Temp Warn -</td> <td data-bbox="878 1083 1507 1110">Active when control heat sink is within 3°C of Int Overtemp.</td> </tr> <tr> <td data-bbox="667 1117 829 1144">Process Error -</td> <td data-bbox="878 1117 1565 1192">Active when process feedback signal is outside the Level 2 Process Control block, PROC ERR TOL parameter value. Turns off when process feedback error is within tolerance.</td> </tr> <tr> <td data-bbox="667 1199 792 1226">Drive Run -</td> <td data-bbox="878 1199 1565 1253">Active when drive is Ready, Enabled, Speed or Torque command received with FWD/REV direction issued.</td> </tr> <tr> <td data-bbox="667 1260 748 1287">Serial –</td> <td data-bbox="878 1260 1175 1287">Active when in Serial mode.</td> </tr> </tbody> </table>	Condition	Description	Ready -	Active when power is applied and no faults are present.	Zero Speed -	Active when motor RPM is below the value of the Level 1 Output “Zero SPD Set Pt” parameter.	At Speed -	Active when output speed is within the speed range defined by the Level 1 Output “At Speed Band” parameter.	At Set Speed -	Active when output speed is at or above the Level 1 Output “Set Speed” parameter.	Overload -	Active during an Overload fault caused by a time out when output current is greater than Rated Current.	Keypad Control -	Active when control is in Local keypad control.	Fault -	Active when a fault condition is present.	Following ERR -	Active when the motor speed is outside the user specified tolerance band defined by the At Speed Band parameter.	Motor Direction -	Active High when REV direction feedback is sensed. Active Low when FWD direction feedback is sensed.	Drive On -	Active when control is “Ready” (has reached excitation level and capable of producing torque).	CMD Direction -	Active when Forward or Reverse is selected or enabled. Logical output state indicates Forward or Reverse direction. High=FWD, Low=REV.	AT Position -	Active during an internal positioning command when control is within the position band parameter tolerance.	Over Temp Warn -	Active when control heat sink is within 3°C of Int Overtemp.	Process Error -	Active when process feedback signal is outside the Level 2 Process Control block, PROC ERR TOL parameter value. Turns off when process feedback error is within tolerance.	Drive Run -	Active when drive is Ready, Enabled, Speed or Torque command received with FWD/REV direction issued.	Serial –	Active when in Serial mode.
	Condition	Description																																		
	Ready -	Active when power is applied and no faults are present.																																		
	Zero Speed -	Active when motor RPM is below the value of the Level 1 Output “Zero SPD Set Pt” parameter.																																		
At Speed -	Active when output speed is within the speed range defined by the Level 1 Output “At Speed Band” parameter.																																			
At Set Speed -	Active when output speed is at or above the Level 1 Output “Set Speed” parameter.																																			
Overload -	Active during an Overload fault caused by a time out when output current is greater than Rated Current.																																			
Keypad Control -	Active when control is in Local keypad control.																																			
Fault -	Active when a fault condition is present.																																			
Following ERR -	Active when the motor speed is outside the user specified tolerance band defined by the At Speed Band parameter.																																			
Motor Direction -	Active High when REV direction feedback is sensed. Active Low when FWD direction feedback is sensed.																																			
Drive On -	Active when control is “Ready” (has reached excitation level and capable of producing torque).																																			
CMD Direction -	Active when Forward or Reverse is selected or enabled. Logical output state indicates Forward or Reverse direction. High=FWD, Low=REV.																																			
AT Position -	Active during an internal positioning command when control is within the position band parameter tolerance.																																			
Over Temp Warn -	Active when control heat sink is within 3°C of Int Overtemp.																																			
Process Error -	Active when process feedback signal is outside the Level 2 Process Control block, PROC ERR TOL parameter value. Turns off when process feedback error is within tolerance.																																			
Drive Run -	Active when drive is Ready, Enabled, Speed or Torque command received with FWD/REV direction issued.																																			
Serial –	Active when in Serial mode.																																			
	Zero SPD Set PT	Sets the speed at which the Zero Speed opto output becomes active (turns on). When the speed is less than the ZERO SPD SET PT, the Opto Output becomes active. This is useful when a motor brake is to interlock operation with a motor.																																		
	At Speed Band	<p>The At Speed Band serves two Opto Output Conditions and the Level 2 Protection block Following Error:</p> <p>Sets the speed range in RPM at which the At Speed opto output turns on and remains active within the range.</p> <p>Sets the Following Error Tolerance Band for the Level 1 OUTPUT, Opto Output condition Following ERR. The opto output is active if the motor speed is outside this band.</p> <p>Sets the allowable following error speed band. This value is used by the Level 2 Protection block, Following Error parameter (if it is set to ON). If the drive speed falls out of this band, the Level 2 Protection block, Following Error parameter will shut down the drive (if it is set to ON).</p>																																		
	Set Speed	Sets the speed that the AT Set Speed opto output becomes active (turns on). When the speed is greater than the Level 1 Output SET SPEED parameter, the Opto Output becomes active. This is useful when another machine must not start or stop until the motor exceeds a predetermined speed.																																		

**Table 4-4 Inverter Control Board Level 1 Parameter Definitions - Continued**

Block Title	Parameter	Description
OUTPUT (Continued)	Analog Output #1 and #2	<p>Two Analog 0-5VDC linear outputs may be configured to represent any of 19 conditions as follows:</p> <p><b>Condition Description</b></p> <p>ABS Speed - Represents the absolute motor speed where 0VDC = 0 RPM and +5VDC = MAX RPM.</p> <p>ABS Torque - Represents the absolute value of torque where +5VDC = Torque at CURRENT LIMIT.</p> <p>Speed Command - Represents the absolute value of commanded speed where +5VDC = MAX RPM.</p> <p>PWM Voltage - Represents the amplitude of PWM voltage where +5VDC = MAX AC Voltage.</p> <p>Flux Current - Represents the actual portion of total current used for excitation. 5VDC= MAX flux current.</p> <p>CMD Flux CUR - Represents the calculated value for flux current. 5VDC= MAX commanded flux current.</p> <p>Load Current - Represents the actual portion of total current used to produce torque (CW and CCW torque). 5V = Max. CW torque, 0V = Max. CCW torque.</p> <p>CMD Load Current - Represents the calculated value of load current. 5V = Max. commanded load current.</p> <p>Motor Current - Amplitude of continuous current including motor excitation current. 5VDC = Rated Current.</p> <p>Load Component - Amplitude of load current not including the motor excitation current. 5VDC = Rated Current.</p> <p>Quad Voltage - Load controller output. Used to diagnose control problems.</p> <p>Direct Voltage - Flux controller output. Used to diagnose control problems.</p> <p>AC Voltage - A scaled AC waveform that represents the AC line to line motor terminal voltage. 0V = Neg Peak PWM voltage. 2.5V centered. 5V = Pos Peak PWM voltage. At rated motor voltage, a full 0 to 5V sinusoidal waveform should be present. This waveform should be at or greater than the motor base frequency. (At half the motor base frequency, a 1.25V to 3.75 sine wave is present.)</p> <p>Bus Voltage - Bus voltage scaled to 0-5VDC. 5V = 1000VDC.</p> <p>Torque - Bipolar torque output. 2.5V centered, 5V = Max Positive Torque, 0V = Max negative torque.</p> <p>Power - Bipolar power output. 2.5V = Zero Power, 0V = negative rated peak power, +5V = Positive rated peak power.</p> <p>Velocity - Represents motor speed scaled to 0V = negative max RPM, +2.5V = Zero Speed, +5V = positive max RPM.</p> <p>Overload - (Accumulated current)<sup>2</sup> x (time), Overload occurs at +5V.</p> <p>PH 2 Current - Sampled AC phase 2 motor current. 2.5V = zero amps, 0V = negative rated peak amps, +5V = positive rated peak amps.</p> <p>PH 3 Current - Sampled AC phase 1 motor current. 2.5V = zero amps, 0V = negative rated peak amps, +5V = positive rated peak amps.</p> <p>Process Feedback - Represents the selected Process Feedback signal. 2.5V centered, 5V = 100%, 0V = -100%.</p> <p>Setpoint Command - Represents the selected Setpoint Command signal. 2.5V centered, 5V = 100%, 0V = -100%.</p> <p>Position - Position within a single revolution. +5V = 1 complete revolution. The counter will reset to 0 every revolution.</p> <p>Serial - 0-5VDC level that indicates a value programmed by a serial command.</p>
	Analog #1 Scale & Analog #2 Scale	Scale factor for the Analog Output voltage. Useful to set the zero value or full scale range for external meters.
	Position Band	Sets the acceptable range in digital counts (pulses) at which the AT Position Opto becomes active (turns on).

**Table 4-4 Inverter Control Board Level 1 Parameter Definitions - Continued**

Block Title	Parameter	Description
VECTOR CONTROL	CTRL BASE Speed	Sets the speed in RPM at which the saturation voltage of the control is reached. Above this RPM value the control will output constant voltage and variable frequency.
	Feedback Filter	A larger value provides a more filtered signal but at the cost of reduced bandwidth.
	Feedback Align	Sets the encoder's electrical direction of rotation to match that of the motor.
	Current PROP Gain	Sets the current loop proportional gain.
	Current INT Gain	Sets the current loop integral gain.
	Speed PROP Gain	Sets the speed (velocity) loop proportional gain.
	Speed INT Gain	Sets the speed (velocity) loop integral gain.
	Speed DIFF Gain	Sets the speed (velocity) loop differential gain.
	Position Gain	Sets the position loop proportional gain.
	Slip Frequency	Sets the rated slip frequency of the motor.
	Stator R1	Stator resistance in ohms. If set too high, the motor will tend to stall at zero speed when reversing or accelerating from low speed. Reducing this value may eliminate the problem. When too low, speed regulation may suffer.
	Stator X1	Stator leakage reactance, in ohms at 60Hz. This parameter has most impact when reversing motor rotation at full current limit. If set too low, the decel time will tend to increase.
	Prop Gain #1	The anti-saturation controller's proportional gain. Leave the gain at the factory setting. Do not change this gain unless authorized by Baldor.
	INT Gain #1	The anti-saturation controller's integral gain. Leave the gain at the factory setting. Do not change this gain unless authorized by Baldor.
LEVEL 2 BLOCK		ENTERS LEVEL 2 MENU



**Table 4-5 Inverter Control Board Level 2 Parameter Definitions**

Block Title	Parameter	Description
OUTPUT LIMITS	Operating Zone	Sets the PWM operating zone to Standard 2.5KHz or Quiet 8.0KHz output carrier frequency. Two operating modes are also selectable: Constant Torque and Variable Torque. Constant Torque allows 170 - 200% for 3 seconds overload or 150% for 60 seconds overload. Variable Torque allows 115% peak overload for 60 seconds.
	MIN Output Speed	Sets the minimum motor speed in RPM. During operation, the motor speed will not be allowed to go below this value except for motor starts from 0 RPM or during dynamic braking to a stop.
	MAX Output Speed	Sets the maximum motor speed in RPM.
	PK Current Limit	The maximum output peak current to the motor. Values above 100% of the rated current are available depending upon the operating zone selected.
	PWM Frequency	The frequency that the output transistors are switched. PWM frequency is also referred to as "Carrier" frequency. PWM should be as low as possible to minimize stress on the output transistors and motor windings. It is recommended that the PWM frequency be set to approximately 15 times the maximum output frequency of the control. Ratios less than 15 will result in non-Sinusoidal current waveforms. See Figure 4-3.
	CUR Rate Limit	Limits the rate of torque change in response to a torque command.
CUSTOM UNITS	Decimal Places	The number of decimal places of the Output Rate display on the Keypad display. This value will be automatically reduced for large values. The output rate display is only available if the Value At Speed parameter value is non zero.
	Value At Speed	Sets the desired output rate per RPM of motor speed. Two numbers are displayed on the keypad display (separated by a slash "/"). The first number (left most) is the value you want the keypad to display at a specific motor speed. The second number (right most) is the motor RPM corresponding to the units in the first number. A decimal may be inserted into the left numbers by placing the flashing cursor over the up/down arrow and use the arrow keys.
	Units of Measure	Allows user specified units of measure to be displayed on the Output Rate display. Use the shift and arrow keys to scroll to the first and successive characters. If the character you want is not displayed, move the flashing cursor over the special up/down character arrow on the left side of the display. Use the up/down arrows and the shift key to scroll through all 9 character sets. Use the ENTER key to save your selection.
PROTECTION	Overload	Sets the protection mode to Fault (trip off during overload condition) or to Foldback (automatically reduce the output current below the continuous output level) during an overload. Foldback is the choice if continuous operation is desired. Fault will require the control be "Reset" manually or automatically after an overload.  Note: The "Foldback" selection may not be available on some early versions of the software.
	External Trip	OFF - External Trip is Disabled. ON - External Trip is enabled. If a normally closed contact at J1-16 is opened, an External Trip fault will occur and cause the drive to shut down.
	Local Enable INP	OFF - Ignores J1-8 input when in the "LOCAL" mode. ON - Requires J1-8 input to be closed to enable the control when in the "LOCAL" mode.
	Following Error	This parameter determines if the control is to monitor the amount of following error that occurs in an application. Following Error is the programmable tolerance for the AT Speed Opto output as defined by the Level 1 Output block, AT Speed Band parameter. Operation outside the speed range will cause a fault and the drive will shut down.
	Torque Proving	When this parameter is set to ON the control measures output current in all three phases to the motor. If output current is unbalanced, the control will trip off generating a torque proving fault. In a hoist application, for example, this is useful to ensure that motor torque exists before the fail safe brake is released. "Drive On" output, if programmed, will not occur if torque proving fails.

**Figure 4-3 Maximum Output Frequency vs PWM Frequency**

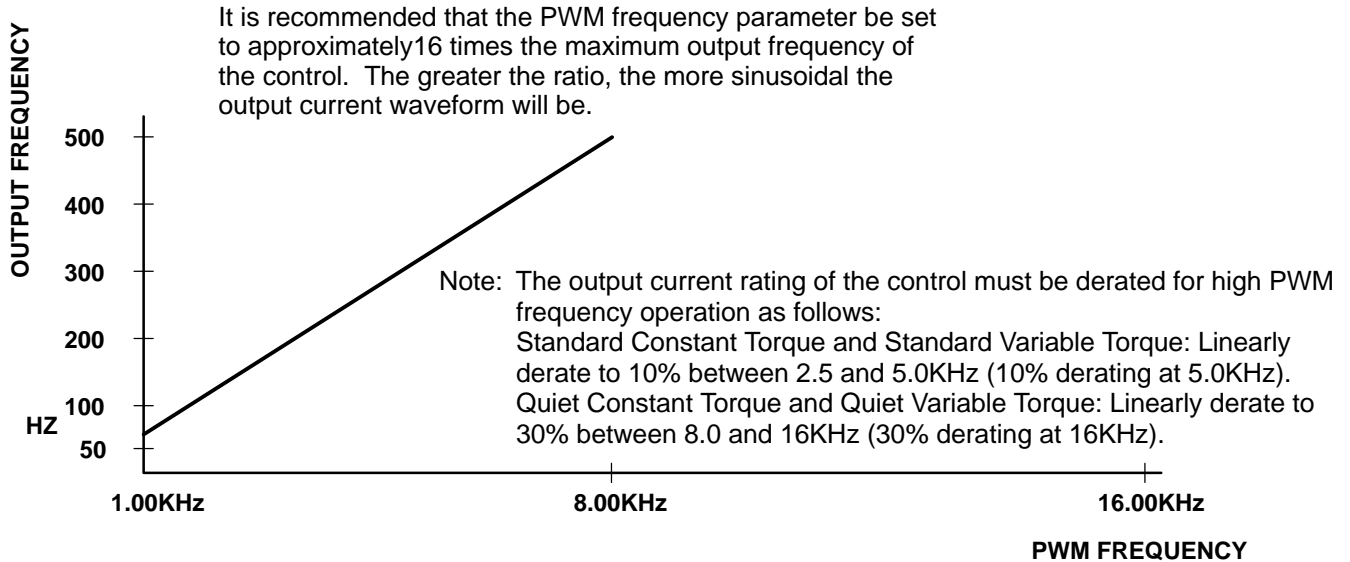

**Table 4-5 Inverter Control Board Level 2 Parameter Definitions - Continued**

Block Title	Parameter	Description
MISCELLANEOUS	Restart Auto/Man	Manual - If a fault or power loss occurs, the control must be manually reset to resume operation. Automatic - If a fault or power loss occurs, the control will automatically reset to resume operation.
	Restart Fault/Hr	The maximum number of automatic restart attempts before requiring a manual restart. After one hour without reaching the maximum number of faults or if power is turned off and on again, the fault count is reset to zero.
	Restart Delay	The amount of time allowed after a fault condition for an automatic restart to occur. Useful to allow sufficient time to clear a fault before restart is attempted.
	Factory Settings	Restores factory settings for all parameter values. Select YES and press "ENTER" key to restore factory parameter values. The keypad Display will show "Operation Done" then return to "NO" when completed.  Note: When factory settings are reset, the Motor Rated Amps value is reset to 999.9 amps. This Level 2 Motor Data block parameter value must be changed to the correct value (located on the motor rating plate) before attempting to start the drive.
	Homing Speed	In Bipolar and Serial modes, this parameter sets the speed that the motor shaft will rotate to a "Home" position when the orient command is issued.
	Homing Offset	In Bipolar and Serial modes, this parameter sets the number of digital encoder counts past home at which the motor zero speed command is issued. Quadrature encoder pulses are 4 times the number of encoder lines per revolution. The recommended minimum number is 100 encoder counts to allow for deceleration distance to allow the motor to stop smoothly.  Note: Homing direction is always in the forward direction.

**Table 4-5 Inverter Control Board Level 2 Parameter Definitions - Continued**

Block Title	Parameter	Description
SECURITY CONTROL	Security State	<p>Off - No security Access Code required to change parameter values.</p> <p>Local - Requires security Access Code to be entered (using the keypad) before parameter changes can be made using the Keypad.</p> <p>Serial - Requires security Access Code to be entered (over the Serial Link) before parameter changes can be made using the Serial Link.</p> <p>Total - Requires security Access Code to be entered (using Keypad or Serial Link) before parameter changes can be made using the Keypad or serial link.</p> <p>Note: If security is set to Local, Serial or Total you can press PROG and scroll through the parameter values and view their values but you are not allowed to change their values unless you enter the correct access code.</p>
	Access Timeout	<p>The time in seconds the security access remains enabled after leaving the programming mode. If you exit and go back into the program Mode within this time limit, the security Access Code does not have to be re-entered. This timer starts when leaving the Program Mode (by pressing DISP).</p> <p>Note: This feature is not available when using the Serial operating mode or if power is cycled.</p>
	Access Code	<p>A 4 digit number code. Only persons that know the code can change secured Level 1 and Level 2 parameter values.</p> <p>Note: Please record your access code and store it in a safe place. If you cannot gain entry into parameter values to change a protected parameter, please contact Baldor. Be prepared to give the 5 digit code shown on the lower right side of the Keypad Display at the Security Control Access Code parameter prompt.</p>
MOTOR DATA	Motor Voltage	The rated voltage of the motor (listed on the motor nameplate).
	Motor Rated Amps	The full load current of the motor (listed on the motor nameplate). If the motor current exceeds this value for a period of time, an Overload fault will occur.
	Motor Rated SPD	The rated speed of the motor (listed on the motor nameplate). If Motor Rated SPD = 1750 RPM and Motor Rated Freq = 60 Hz, the Keypad Display will show 1750 RPM at 60 Hz and 875 RPM at 30Hz.
	Motor Rated Freq	The rated frequency of the motor (listed on the motor nameplate).
	Motor Mag Amps	The motor magnetizing current value (listed on the motor nameplate). Also called no load current. Measure using a clamp on amp meter at the AC power line while the motor is running at line frequency with no load connected to the motor shaft.
	Encoder Counts	The number of encoder feedback counts (lines per revolution).
	Resolver Speed	The speed of the resolver, if a resolver is used for feedback.
	CALC Presets	This procedure loads preset values into memory that are required to perform Auto Tune. Always run CALC Presets as the first step of Auto Tune.

**Table 4-5 Inverter Control Board Level 2 Parameter Definitions - Continued**

<b>Block Title</b>	<b>Parameter</b>	<b>Description</b>
BRAKE ADJUST	Resistor Ohms	The dynamic braking resistor value in ohms. Refer to dynamic braking manual or call Baldor for additional information.
	Resistor Watts	The dynamic braking resistor watts rating. Refer to dynamic braking manual or call Baldor for additional information.
	DC Brake Current	The amount of DC injection brake current. 0% = Flux current, 100% = Motor rated current. (Used during encoderless operation).
PROCESS CONTROL	Process Feedback	Sets the type of signal used for the process feedback signal.
	Process Inverse	Causes the process feedback signal to be inverted. Used with reverse acting processes that use a unipolar signal such as 4-20mA. If "ON", 20mA will decrease motor speed and 4mA will increase motor speed.
	Setpoint Source	Sets the source input signal to which the process feedback will be compared. If "Setpoint CMD" is selected, the fixed value of the set point is entered in the Setpoint Command parameter value.
	Setpoint Command	Sets the value of the setpoint the control will try to maintain by adjusting motor speed. This is only used when the Setpoint Source is a fixed value "Setpoint CMD" under Setpoint Source.
	Set PT ADJ Limit	Sets the maximum speed correction value to be applied to the motor (in response to the maximum feedback setpoint error). For example, if the max motor speed is 1750 RPM, the setpoint feedback error is 100% and the setpoint adjustment limit is 10%, the maximum speed the motor will run in response to the setpoint feedback error is $\pm 175$ RPM. If at the process setpoint, the motor speed is 1500 RPM, the maximum speed adj limits is then 1325 to 1675 RPM.
	Process ERR TOL	Sets the width of the comparison band (% of setpoint) with which the process input is compared. The result is that if the process input is within the comparison band the corresponding Opto Output will become active.
	Process PROP Gain	Sets the PID loop proportional gain. This determines how much adjustment to motor speed or torque (within the Set PT ADJ Limit) is made to reduce process error.
	Process INT Gain	Sets the PID loop Integral gain. This determines how quickly the motor speed or torque is adjusted to correct long term error.
	Process DIFF Gain	Sets the PID loop differential gain. This determines how much adjustment to motor speed (within the Set PT ADJ Limit) is made for transient error.
	Follow I:O Ratio	Sets the ratio of the Master to the Follower in Master/Follower configurations. Requires the Master Pulse Reference/ Isolated Pulse Follower expansion board. For example, the master encoder you want to follow is a 1024 count encoder. The follower motor you wish to control also has a 1024 count encoder on it. If you wish the follower to run twice the speed of the master, a 1:2 ratio is entered. Fractional ratios such as 0.5:1 are entered as 1:2. Ratio limits are (1-65,535) : (1-20).  Note: The Master Encoder parameter must be defined if a value is entered in the Follow I:O Ratio parameter.  Note: When using Serial Communications to operate the control, this parameter value is the MASTER portion of the ratio. The FOLLOWER portion of the ratio is set in the Follow I:O Out parameter.
	Follow I:O Out	This parameter is used only when Serial Communications is used to operate the control. A Master Pulse Reference/ Isolated Pulse Follower expansion board is required. This parameter represents the FOLLOWER portion of the ratio. The MASTER portion of the ratio is set in the Follow I:O Ratio parameter when using Serial operating mode.
Master Encoder	Only used if an optional Master Pulse Reference/Isolated Pulse Follower expansion board is installed. Defines the number of pulses per revolution of the master encoder. Programmed into follower drives only.	
COMMUNICATIONS	Protocol	Sets the type of communication the control is to use, RS-232 ASCII, RS-485 ASCII, RS-232 BBP or RS-485 BBP protocol.
	Baud Rate	Sets the speed at which communication is to occur.
	Drive Address	Sets the address of the control for communication.

**Table 4-5 Inverter Control Board Level 2 Parameter Definitions - Continued**

Block Title	Parameter	Description
AUTO TUNING	<p>CALC Presets</p> <p>CMD Offset Trim</p> <p>CUR Loop COMP</p> <p>Flux CUR Setting</p> <p>Feedback Tests</p> <p>Slip FREQ Test</p> <p>SPD CNTRLR CALC</p>	<p>The Auto Tune procedure is used to automatically measure and calculate certain parameter values. Dynamic Brake Hardware is required to perform “Slip Freq Test” and “Spd Cntrlr Calc” autotuning test. Occasionally, the Auto Tune procedure cannot be run due to various circumstances such as the load cannot be uncoupled from the motor. The control can be manually tuned by entering the parameter values based on calculations you have made. Refer to “Manually Tuning the Control” in the Troubleshooting section of this manual.</p> <p>Loads operating values into memory. These values are based on information programmed into the Level 2 Output Limits and Motor Data parameter values. CALC Presets must be run before Autotuning or manually tuning the drive.</p> <p>This procedure trims out voltage offsets for the differential analog input at J1-4 and J1-5.</p> <p>Measures current response to pulses of one half the rated motor current.</p> <p>Sets motor magnetizing current by running motor at near rated speed.</p> <p>Checks the values for Encoder Lines per revolution and encoder alignment parameters while the motor is running at near full rated speed. Test will automatically switch encoder phasing to match motor rotational direction.</p> <p>Calculates motor Slip Frequency during repeated motor accelerations.</p> <p>Should be performed with the load coupled to the motor shaft. Sets the motor current to acceleration ratio, Speed INT gain and Speed PROP gain values. If done under no load, the Integral gain will be too large for high inertia loads if the PK Current Limit is set too low. If the control is too responsive when the drive is loaded, adjust the PK Current Limit parameter to a greater value and repeat this test.</p>
LEVEL 1 BLOCK		ENTERS LEVEL 1 MENU

## Section 5 Troubleshooting

Baldor Series 22H Controls require very little maintenance and should provide years of trouble free operation when installed and applied correctly. Occasional visual inspection should be considered to ensure tight wiring connections and to avoid the build up of any dust, dirt, or foreign debris which can reduce heat dissipation. The control should be mounted in a location that protects the internal circuits and external wiring from moisture or liquid contaminants.





When a fault condition occurs, motor operation stops and the fault is displayed on the Keypad Display. If a REGEN FLT is displayed, this indicates a fault in the converter section of the control. To determine the specific converter section fault, the keypad must be moved to the Converter Control Board keypad connector. The fault log can be examined and the specific faults will help to further isolate the failure. A list of possible Converter Control Board Fault Messages is given in Table 5-1. Other fault messages that pertain to the Inverter Control Board are given in Table 5-2.

When a fault has been identified, all input power must be removed from the control to avoid the possibility of electrical shock. The servicing of this equipment should be handled by a qualified electrical service technician experienced in the area of high power electronics.

It is important to familiarize yourself with the following information before attempting any troubleshooting or service of the control. Most troubleshooting can be performed using only a digital voltmeter having an input impedance exceeding 1 megOhm. In some cases, an oscilloscope with 5 MHz minimum bandwidth may be useful. Before consulting the factory, check that all power and control wiring is correct and installed per the recommendations given in this manual.

### **No Keypad Display - Display Contrast Adjustment**

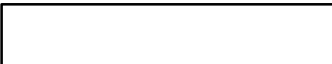
If there is no visible display, use the following procedure to adjust the contrast of the display.

Action	Description	Display	Comments
Apply Power	No visible display.		Display mode with nothing visible.
Press DISP key	Puts control in Display mode.		
Press SHIFT key 2 times	Accesses display contrast adjustment.		
Press ▲ or ▼ key	Adjusts display contrast (intensity).		
Press ENTER key	Saves display contrast adjustment level and exits to display mode.		

**When a Fault is Displayed** When a fault is displayed, press “DISP” so that you can view the menu items (to go to Diagnostic or Fault Log menus etc.). When you exit these menus, the fault message will again be displayed. The control must be reset to clear the fault message from the display.

**Table 5-1 Converter Control Board Fault Messages**





FAULT MESSAGE	DESCRIPTION
Current Sens FLT	Defective phase current sensor or open circuit detected between control board and current sensor.
DC Bus High	Bus over voltage condition occurred.
DC Bus Low	Bus under voltage condition occurred.
GND FLT	Low impedance path detected between an output phase and ground.
High INIT CUR	Phasing between main power connections, zero crossing detectors, line reactor and control does not match.
ID:No Feedback	Control board installed in power base that does not have current feedback and current feedback is required.
INT Over-Temp	Temperature of control heatsink exceeded safe level.
Invalid Base ID	Control does not recognize power base ID.
Logic Supply FLT	Logic power supply not working properly.
Lost AB Phase	Missing phase detected by $\mu$ P.
Lost BC Phase	Missing phase detected by $\mu$ P.
Lost User Data	Battery backed RAM parameters have been lost or corrupted. When fault cleared (Reset), the control should reset to factory preset values.
Low INIT Bus V	Insufficient bus voltage on startup.
Memory Error	EEPROM error occurred. Contact Baldor.
$\mu$ P Reset	Watchdog timer detected error.
New Base ID	Control board sensed a different power base since last time it was powered up.
No Faults	Fault log is empty.
Overcurrent FLT	Instantaneous over current condition detected by bus current sensor.
Overload	Output current exceeded allowable rating.
PWR Base FLT	Desaturation of power device occurred or bus current threshold exceeded.
Sync To Line	Incorrect line phasing or frequency detected on startup.

**Table 5-2 Inverter Control Board Fault Messages**

FAULT MESSAGE	DESCRIPTION
Current Sens FLT	Defective phase current sensor or open circuit detected between control board and current sensor.
DC Bus High	Bus over voltage condition occurred.
DC Bus Low	Bus under voltage condition occurred.
Encoder Loss	Encoder coupling slipping or broken; noise on encoder lines, encoder power supply loss or defective encoder.
External Trip	An open circuit on J1-16 typically indicating an external over temperature condition.
Following Error	Excessive following error detected between command and feedback signals.
GND FLT	Low impedance path detected between an output phase and ground.
INT Over-Temp	Temperature of control heatsink exceeded safe level.
Invalid Base ID	Control does not recognize power base ID.
Inverter Base ID	Control board installed on power base without current feedback.
Line Regen FLT	Indicates a converter section fault.
Logic Supply FLT	Logic power supply not working properly.
Lost User Data	Battery backed RAM parameters have been lost or corrupted. When fault cleared (Reset), the control should reset to factory preset values.
Low INIT Bus V	Insufficient bus voltage on startup.
Memory Error	EEPROM error occurred. Contact Baldor.
New Base ID	Control board sensed a different power base since last time it was powered up.
No Faults	Fault log is empty.
No EXB Installed	Programmed parameter requires an expansion board.
Over Current FLT	Instantaneous over current condition detected by bus current sensor.
Overload - 1 min	Output current exceeded 1 minute rating.
Overload - 3 sec	Output current exceeded 3 second rating.
Over speed	Motor RPM exceeded 110% of programmed MAX Motor Speed.
µP Reset	Power cycled before the residual Bus voltage reached 0VDC.
PWR Base FLT	Desaturation of power device occurred or bus current threshold exceeded.
Resolver Loss	Resolver feedback problem is indicated (if resolver used).
Torque Prove FLT	Unbalanced current between all 3 motor phases.
User Fault Text	Custom software operating fault occurred.





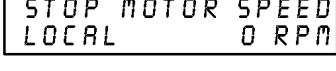





**How to Access the Fault Log** When a fault condition occurs, motor operation stops and a fault code is displayed on the keypad display. The control keeps a log of up to the last 31 faults. If more than 31 faults have occurred the oldest fault will be deleted from the fault log to make room for the newest fault. To access the fault log use the following procedure:

Action	Description	Display	Comments
Apply Power			Logo display for 5 seconds.
	Display mode showing output frequency		Display mode.
Press DISP key 5 times	Use DISP key to scroll to the Fault Log entry point.		
Press ENTER key	Display first fault type and time fault occurred.		Typical display.
Press ▲ key	Scroll through fault messages.		If no messages, the fault log exit choice is displayed.
Press ENTER key	Return to display mode.		Display mode stop key LED is on.

**How to Clear the Fault Log** Use the following procedure to clear the fault log and reset the internal clock.

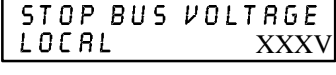
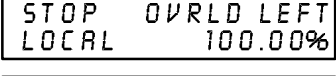
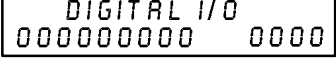
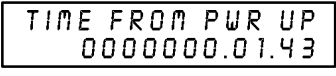
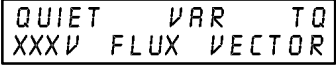
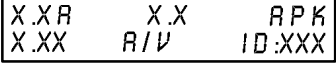
Action	Description	Display	Comments
Apply Power		<pre>BALDOR MOTORS &amp; DRIVES</pre>	Logo display for 5 seconds.
	Display mode showing output frequency.	<pre>STOP MOTOR SPEED LOCAL          0 RPM</pre>	Display mode.
Press DISP key	Press DISP to scroll to the Fault Log entry point.	<pre>PRESS ENTER FOR FAULT LOG</pre>	
Press ENTER key	Displays most recent message.	<pre>EXTERNAL TRIP 1: 00000:00:30</pre>	1=Most recent fault. 2=Second most recent fault, etc.
Press SHIFT key		<pre>EXTERNAL TRIP 1: 00000:00:30</pre>	
Press RESET key		<pre>EXTERNAL TRIP 1: 00000:00:30</pre>	
Press SHIFT key		<pre>EXTERNAL TRIP 1: 00000:00:30</pre>	
Press ENTER key	Fault log is cleared.	<pre>FAULT LOG NO FAULTS</pre>	No faults in fault log. Also resets the internal clock.
Press ▲ or ▼ key	Scroll Fault Log Exit.	<pre>PRESS ENTER FOR FAULT LOG EXIT</pre>	
Press ENTER key	Return to display mode.	<pre>STOP MOTOR SPEED LOCAL          0 RPM</pre>	

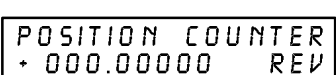
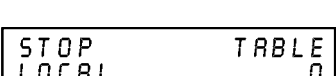
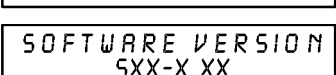
## How to Access Diagnostic Information

Action	Description	Display	Comments
Apply Power			Logo display for 5 seconds.
	Display mode showing motor speed.		No faults present. Local keypad mode. In remote/serial mode, disable drive then press local for this display.
Press DISP key 6 times	Scroll to Diagnostic Information screen		Diagnostic Access screen.
Press ENTER key	Access diagnostic information.		First Diagnostic Information screen.
Press DISP key	Display showing control temperature.		
Press DISP key	Display showing bus voltage.		
Press DISP key	Display showing % overload current remaining.		
Press DISP key	Display showing opto inputs & outputs states. 0=OPEN, 1=CLOSED.		Opto Inputs states (Left); Opto Outputs states (Right).
Press DISP key	Display showing actual drive running time.		HR.MIN.SEC format.
Press DISP key	Display showing operating zone, voltage and control type.		
Press DISP key	Display showing continuous amps; PK amps rating; amps/volt scale of feedback, power base ID.		ID is displayed as a hexadecimal value.
Press DISP key	Display showing which Group1 or 2 expansion boards are installed and recognized.		
Press DISP key	Display showing motor shaft revolutions from the REV home set point.		
Press DISP key	Display mode showing parameter table selected.		
Press DISP key	Display showing software version and revision installed in the control.		
Press DISP key	Displays exit choice.		Press ENTER to exit diagnostic information.

**Table 5-3 Converter Section Troubleshooting**

INDICATION	POSSIBLE CAUSE	CORRECTIVE ACTION
Current Sense FLT	Open circuit between control board and current sensor or defective current sensor.	Check control wires between control board and current feedback sensor.
DC Bus High	Incorrect setting of converter bridge parameter.	Check Bus Capacitance value of converter section parameters.
	Decel rate too fast.	Increase Decel time parameter setting.
DC Bus Low	Input voltage too low.	Monitor power line fluctuations with date and time imprint to isolate power problem. Check power line disturbances (sags caused by start up of other equipment). Use step up isolation transformer if needed.
GND FLT	Improper wiring.	Disconnect wiring between control and motor. Retry test. If GND FLT is cleared, reconnect motor leads and retry the test. Rewire as necessary. Repair motor. If GND FLT remains, contact Baldor.
High INIT CUR	Incorrect phasing between input power, filter assembly and line reactors.	Check connections for proper phasing as detailed in Section 3 of this manual.
ID:No Feedback	Control board is installed on wrong power base.	Change power base to one that has current feedback sensors.
INT Over-Temp	Ambient temperature too high.	Relocate control to a cooler area. Add cooling fans or air condition the cabinet.
	Drive overloaded.	Verify proper sizing of control and motor. Correct loading of motor.
	Cooling fans or air path is clogged.	Clean fans and air path. Ensure fans are operating.
Invalid Base ID	Control does not recognize converter power base.	Press "RESET" key on keypad. If fault remains, call Baldor.
Logic Supply FLT	Power supply malfunctioned.	Replace logic power supply.
Lost AB Phase	Wire disconnected or phase lost.	Check for input power on all 3 phases. Check wiring and correct errors in all output wiring and wiring between individual components on EK type controls. Press "RESET" key on keypad. If fault remains, call Baldor.
Lost BC Phase	Wire disconnected or phase lost.	Check for input power on all 3 phases. Check wiring and correct errors in all output wiring and wiring between individual components on EK type controls. Press "RESET" key on keypad. If fault remains, call Baldor.
Lost User Data	Battery backed memory failure.	Parameter data was erased. Disconnect power to control and apply power (cycle power). Enter all parameters. Cycle power. If problem persists, contact Baldor.
Low INIT Bus V	Improper AC line voltage.	Check input AC voltage level.
Memory Error	EEPROM memory fault occurred.	Press "RESET" key on keypad. If fault remains, call Baldor.
µP Reset	Power was cycled before Bus voltage reached 0VDC.	Press "RESET" key on keypad. Disconnect power and allow at least 5 minutes for Bus capacitors to discharge before applying power. If fault remains, call Baldor.
New Base ID	Software parameters are not initialized on newly installed control board.	Press "RESET" key on keypad to clear the fault condition. Cycle power (turn power OFF then ON). Refer to Section 4 and initialize new software. Access diagnostics and compare power base ID number to list in Table 5-5 to ensure a match. Re-enter the Parameter Block Values you recorded in the User Settings at the end of this manual. Autotune the control. If fault remains, call Baldor.

Continued on next page.

**Table 5-3 Converter Section Troubleshooting** Continued

<b>INDICATION</b>	<b>POSSIBLE CAUSE</b>	<b>CORRECTIVE ACTION</b>
Over Current FLT	Possible converter transistor failure.	Check transistors for shorted junctions.
	Incorrect inductance set in Line Inductor parameter.	Check inductance parameter value.
Overload FLT	Drive overloaded.	Verify proper sizing of control and motor.
PWR Base FLT	Incorrect phase connections.	Check connections for proper phasing of EK drive components as detailed in Section 3 of this manual.
	Excessive current draw.	Disconnect motor wiring and retry test. If fault remains, call Baldor.
	Power device saturated.	
	Electrical noise from DC coils.	Install flyback diodes (reverse biased 1N4002 or equivalent) across all external DC relay coils..
Electrical noise from AC coils.	Install RC snubbers on all external AC coils.	
Sync To Line	Incorrect phase connections.	Check connections for proper phasing as detailed in Section 3 of this manual.
	Incorrect frequency detected at startup.	Check incoming line voltage and frequency.

**Table 5-4 Inverter Section Troubleshooting**

INDICATION	POSSIBLE CAUSE	CORRECTIVE ACTION
No Display	Lack of input voltage.	Check input power for proper voltage. Verify fuses are good (or breaker is not tripped).
	Loose connections.	Check input power termination. Verify connection of operator keypad.
	Bent pins in keypad to control connector.	Check connector pins and straighten as required.
	Adjust display contrast.	See Adjust Display Contrast in Sec. 4.
Auto Tune Encoder Test failed	Encoder miswired.	Correct wiring problems.
	Encoder coupling slipping, broken or misaligned.	Correct encoder to motor coupling.
	Excessive noise on encoder lines.	Check the position counter in the Diagnostic Information for jittering which will confirm an encoder problem. Use recommended encoder cable. Check encoder connections including shields. Separate encoder leads from power wiring. Cross encoder wires and power leads at 90°. Electrically isolate encoder from motor. Install optional Isolated Encoder Feedback expansion board.
	Wrong parameter values for "Motor Base Speed", "Frequency" or "Encoder Counts".	Enter correct parameter values.
	Motor coupled to load.	Disconnect load then autotune.
Current Sense FLT	Open circuit between control board and current sensor.	Check connections between control board and current sensor.
	Defective current sensor.	Replace current sensor.
DC Bus High	Excessive regenerated power.	Increase the DECEL time.
	Input voltage too high.	Verify proper AC line voltage. Use step down isolation transformer if needed. Use line reactor to minimize spikes.
DC Bus Low	Input voltage too low.	Disconnect dynamic brake hardware and repeat operation. Verify proper AC line voltage. Use step up isolation transformer if needed. Check power line disturbances (sags caused by start up of other equipment). Monitor power line fluctuations with date and time imprint to isolate power problem.
Encoder Loss	Encoder power supply failure.	Check 5VDC at J1-29 and J1-30. Also check at encoder end pins D and F. Check encoder cable continuity.
	Encoder coupling slipping, broken or misaligned	Correct or replace encoder to motor coupling.
	Excessive noise on encoder lines.	Check the position counter in the Diagnostic Information for jittering which will confirm an encoder problem. Check encoder connections. Separate encoder leads from power wiring. Use Baldor encoder cable. Cross encoder wires and power leads at 90°. Electrically isolate encoder from motor. Install optional Isolated Encoder Feedback expansion board.

Continued on next page.

**Table 5-4 Inverter Section Troubleshooting** Continued

INDICATION	POSSIBLE CAUSE	CORRECTIVE ACTION
External Trip	Motor ventilation insufficient.	Clean motor air intake and exhaust. Check external blower for operation. Verify motor's internal fan is coupled securely. Verify correct line power to external blower.
	Motor draws excessive current.	Check motor for overloading. Verify proper sizing of control and motor.
	No thermostat connected.	Connect thermostat. Verify connection of all external trip circuits used with thermostat. Disable thermostat input at J1-16 (External Trip Input).
	Poor thermostat connections.	Check thermostat connections.
	External trip parameter incorrect.	Verify connection of external trip circuit at J1-16. Set external trip parameter to "OFF" if no connection made at J1-16.
Following ERR	Speed proportional gain set too low.	Following error tolerance band set too narrow. Increase Speed PROP Gain parameter value.
	Current limit set too low.	Increase Current Limit parameter value.
	ACCEL/DECEL time too short.	Increase ACCEL/DECEL parameter time
	Excessive load.	Verify proper sizing of control and motor.
GND FLT	Improper wiring.	Disconnect wiring between control and motor. Retry test. If GND FLT is cleared, reconnect motor leads and retry the test. Rewire as necessary. Repair motor. If GND FLT remains, contact Baldor.
	Wiring shorted in conduit. Motor winding shorted.	
INT Over-Temp	Motor Overloaded.	Correct motor loading. Verify proper sizing of control and motor.
	Ambient temperature too high.	Check that air flow path is clean and free of debris. Relocate control to cooler operating area. Add cooling fans or air conditioner to control cabinet.
Invalid Base ID	Control does not recognize HP and Voltage configuration.	Press "RESET" key on keypad. If fault remains, access diagnostic info and compare power output section Power Base ID # with Table 5-5. If different, contact Baldor.
Inverter Base ID	Power base with no output phase current sensors being used.	Replace power base with one that has output leg current feedback. Contact Baldor.
Logic Supply FLT	Power supply malfunctioned.	Replace logic power supply.
Lost User Data	Battery backed memory failure.	Parameter data was erased. Disconnect power to control and apply power (cycle power). Enter all parameters. Cycle power. If problem persists, contact Baldor.
Low INIT Bus V	Improper AC line voltage.	Check input AC voltage level.
Memory Error	EEPROM memory fault occurred.	Press "RESET" key on keypad. If fault remains, call Baldor.
μP Reset	Power was cycled before Bus voltage reached 0VDC.	Press "RESET" key on keypad. Disconnect power and allow at least 5 minutes for Bus capacitors to discharge before applying power. If fault remains, call Baldor.

Continued on next page.

**Table 5-4 Inverter Section Troubleshooting** Continued

INDICATION	POSSIBLE CAUSE	CORRECTIVE ACTION
Motor has wrong response to Speed Command	Analog input common mode voltage may be excessive.	Connect control input source common to control common to minimize common mode voltage. Maximum common mode voltage at terminals J1-4 and J1-5 is $\pm 15\text{VDC}$ referenced to chassis common.
	Incorrect MIN or MAX speed settings.	Check Level 2 Output Limits block, MIN Output Speed and MAX Output Speed parameter values and adjust as needed.
	Analog offset trim is incorrectly set.	Re-run "Offset Trim" autotune test.
	Speed gain value is too large.	Reduce the Level 1 Vector Control block, Speed PROP Gain and Speed INT Gain parameter values.
Motor Shaft Oscillates back and forth	Incorrect encoder alignment direction.	Change the Feedback Align parameter in the Level 1 Vector Control block. If Reverse, set to Forward. If Forward, set to Reverse.
Motor Shaft rotates at low speed regardless of commanded speed	Incorrect encoder alignment direction.	Check encoder connections. Change the Feedback Align parameter in the Level 1 Vector Control block. If Reverse, set to Forward. If Forward, set to Reverse.
Motor Shaft rotates in wrong direction	Incorrect encoder wiring.	Reverse the A and $\bar{A}$ or B and $\bar{B}$ encoder wires at the J1 input to control and change encoder direction in the Feedback Align parameter in the Level 1 Vector Control block.
Motor Will Not Start	Not enough starting torque.	Increase Current Limit setting.
	Motor overloaded.	Check for proper motor loading. Check couplings for binding. Verify proper sizing of control and motor.
	Motor may be commanded to run below minimum speed setting.	Increase speed command or reduce minimum speed setting.
	Incorrect Command Select parameter.	Change Command Select parameter to match wiring at J1.
	Incorrect speed command.	Verify control is receiving proper command signal at J1.
Motor Will Not Reach Maximum Speed	Max Output Speed set too low.	Adjust Level 2 Output Limits block, MAX Output Speed parameter value.
	Motor overloaded.	Check for mechanical overload. If unloaded motor shaft does not rotate freely, check motor bearings.
	Improper speed command.	Verify control is set to proper operating mode to receive speed command. Verify control is receiving proper command signal at input terminals. Check velocity loop gains.
	Speed potentiometer failure.	Replace potentiometer.
Motor Will Not Stop Rotation	MIN Output Speed parameter set too high.	Adjust MIN Output Speed parameter value.
	Improper speed command.	Verify control is receiving proper command signal at input terminals. Verify control is set to receive speed command.
	Speed potentiometer failure.	Replace potentiometer.
	Analog input common mode voltage may be excessive.	Connect control input source common to control common (J1-1) to minimize common mode voltage. Maximum common mode voltage at terminals J1-4 and J1-5 is $\pm 15\text{VDC}$ referenced to chassis common.
	Analog offset trim set incorrectly.	Re-run "Offset Trim" autotune test. Adjust the Level 1 Input block, ANA CMD Offset parameter to obtain zero speed.

Continued on next page.



**Table 5-4 Inverter Section Troubleshooting** Continued

INDICATION	POSSIBLE CAUSE	CORRECTIVE ACTION
New Base ID	Software parameters are not initialized on newly installed control board.	Press "RESET" key on keypad to clear the fault condition. Reset parameter values to factory settings. Access diagnostics and compare power base ID number to list in Table 5-5 to ensure a match. Re-enter the Parameter Block Values you recorded in the User Settings at the end of this manual. Autotune the control.
No EXB Installed	Incorrect programmed parameter.	Change the Level 1 Input block, Command Select parameter and the Level 2 Process Control block, Process Feedback and Setpoint Source parameters to a value that does not require an expansion board.
	Need expansion board.	Install the correct expansion board for selected operating mode.
Over Current FLT	Current Limit parameter set lower than drive rating.	Increase the Level 2 Output Limits block, PK Current Limit parameter. Do not exceed drive rating.
	ACCEL/DECEL time too short.	Increase the Level 1 ACCEL/DECEL Rate block ACCEL/DEC parameters.
	Encoder coupling slipping, broken or misaligned.	Correct or replace encoder to motor coupling.
	Encoder bearing failure.	Replace encoder.
	Excessive noise on encoder lines.	Check the position counter in the Diagnostic Information for jittering which will confirm an encoder problem. Check encoder connections. Separate encoder leads from power wiring. Use Baldor encoder cable. Cross encoder wires and power leads at 90°. Electrically isolate encoder from motor. Install optional Isolated Encoder Feedback expansion board.
	Electrical noise from external DC coils.	Install reverse biased diodes across all external DC relay coils as shown in the Opto Output circuit examples of this manual. See Electrical Noise Considerations in Section 5 of this manual.
	Electrical noise from external AC coils.	Install RC snubbers on all external AC coils. See Electrical Noise Considerations in Section 5 of this manual.
Overload - 3 Sec FLT	Excessive load.	Reduce the motor load. Verify proper sizing of control and motor.
	Peak output current exceeded 3 second rating.	Check the Level 2 Output Limits block PK Current Limit parameter. Change the Level 2 Protection block Overload parameter from Trip to Foldback. Check motor for overloading. Increase Level 1 ACCEL/DECEL Rate block ACCEL/DEC parameters. Reduce motor load. Verify proper sizing of control and motor.
	Encoder coupling slipping, broken or misaligned.	Correct or replace encoder to motor coupling.
Overload - 1 Min FLT	Encoder bearing failure.	Replace encoder.
	Peak output current exceeded 1 minute rating.	Verify proper motor data has been entered. Check the Level 2 Output Limits block PK Current Limit parameter. Change the Level 2 Protection block Overload parameter from Trip to Foldback. Check motor for overloading. Increase Level 1 ACCEL/DECEL Rate block ACCEL/DEC parameters. Reduce motor load. Verify proper sizing of control and motor.
	Encoder coupling slipping, broken or misaligned.	Correct or replace encoder to motor coupling.
Over Speed	Motor exceeded 110% of MAX Speed parameter value.	Check the Level 2 Output Limits block Max Output Speed. Increase the Level 1 Vector Control block Speed PROP Gain.

Continued on next page.

**Table 5-4 Inverter Section Troubleshooting** Continued

INDICATION	POSSIBLE CAUSE	CORRECTIVE ACTION
Power Module	Power supply failure.	Press "RESET" key on keypad. If fault remains, call Baldor.
PWR Base FLT	Improper ground	Be sure control has separate ground wire to earth ground. Panel grounding or conduit connections is not sufficient. Disconnect motor leads from control and retry test. If fault remains, call Baldor.
	Excessive current usage.	
	Encoder coupling slipping, broken or misaligned.	Correct or replace encoder to motor coupling.
	Encoder bearing failure.	Replace encoder.
	Excessive noise on encoder lines.	Check encoder connections. Separate encoder leads from power wiring. Use Baldor encoder cable. Cross encoder wires and power leads at 90°. Electrically isolate encoder from motor. Install optional Isolated Encoder Feedback expansion board.
	Electrical noise from external DC coils.	Install reverse biased diodes across all external DC relay coils as shown in the Opto Output circuit examples of this manual. See Electrical Noise Considerations in Section 5 of this manual.
	Electrical noise from external AC coils.	Install RC snubbers on all external AC coils. See Electrical Noise Considerations in Section 5 of this manual.
	Excessive load.	Correct motor load. Verify proper sizing of control and motor.
Regen PWR FLT	Excessive power in dynamic brake circuit.	Verify proper Ohm and Watt parameters of Brake Adjust block. Increase decel time.
	Excessive input voltage.	Verify proper AC Line voltage. Use step down transformer if needed. Use line reactor to minimize spikes.
Resolver Loss	Resolver defect.	Check resolver to motor coupling (align or replace if needed). Verify correct wiring. Refer to the Resolver to Digital expansion board manual. Electrically isolate resolver from motor. Use Baldor Resolver cable.
Torque Prove FLT	Unbalanced current in 3 motor phases.	Check continuity from control to motor windings and verify motor connections.
Unknown Fault	Fault occurred but cleared before its source could be identified.	Check AC line for high frequency noise. Check input switch connections and switching noise.
User Fault Text	Fault detected by custom software.	Refer to custom software fault list.

**Table 5-5 Power Base ID - Series 22H**

230VAC		460VAC	
Catalog Numbers	Power Base ID No.	Catalog Numbers	Power Base ID No.
ZD22H210-EL	919	ZD22H410-EL	B2D
ZD22H215-EL	910	ZD22H415-EK	B10
ZD22H220-EL	911	ZD22H420-EL	B11
ZD22H225-EL	91D	ZD22H425-EL	B12
ZD22H230-EL	913	ZD22H430-EL	B13
ZD22H240-EL	914	ZD22H440-EL	B14
ZD22H250-EL	915	ZD22H450-EL	B15
		ZD22H460-EK	B16
		ZD22H475-EK	BAB
		ZD22H4100-EK	B18
		ZD22H4150-EK	B9A
		ZD22H4200-EK	B9B
		ZD22H4250-EL	BC3
		ZD22H4300-EL	BAE
		ZD22H4350-EL	BA6
		ZD22H4400-EL	BA7
		ZD22H4450-EL	BA9

Note: The Power Base ID number of a control is displayed in a Diagnostic Information screen as a hexadecimal value.

Note: The power Base ID number is the same for both the converter and the Inverter sections of the control.

---

**Electrical Noise Considerations** All electronic devices are vulnerable to significant electronic interference signals (commonly called “Electrical Noise”). At the lowest level, noise can cause intermittent operating errors or faults. From a circuit standpoint, 5 or 10 millivolts of noise may cause detrimental operation. For example, analog speed and torque inputs are often scaled at 5 to 10 VDC maximum with a typical resolution of one part in 1,000. Thus, noise of only 5 mV represents a substantial error.

At the extreme level, significant noise can cause damage to the drive. Therefore, it is advisable to prevent noise generation and to follow wiring practices that prevent noise generated by other devices from reaching sensitive circuits. In a control, such circuits include inputs for speed, torque, control logic, and speed and position feedback, plus outputs to some indicators and computers.

Unwanted electrical noise can be produced by many sources. Various methods can be used to reduce the effects of this noise. All methods are less costly when designed into a system initially than if added after installation.

**Relay and Contactor Coils** Among the most common sources of noise are the ever-present coils of contactors and relays. When these highly inductive coil circuits are opened, transient conditions often generate spikes of several hundred volts in the control circuit. These spikes can induce several volts of noise in an adjacent wire that runs parallel to a control-circuit wire.

Figure 5-1 illustrates noise suppression for AC and DC operated coils.

**Figure 5-1 AC & DC Coil Noise Suppression**

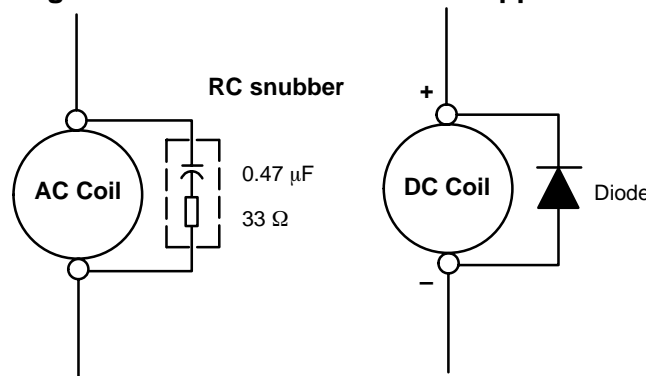

### Wires between Controls and Motors

Output leads from a typical 460 VAC drive controller contain rapid voltage rises created by power semiconductors switching 650V in less than a microsecond, 1,000 to 10,000 times a second. These noise signals can couple into sensitive drive circuits. If shielded pair cable is used, the coupling is reduced by nearly 90% compared to unshielded cable.

Even input AC power lines contain noise and can induce noise in adjacent wires. In severe cases, line reactors may be required.

To prevent induced transient noise in signal wires, all motor leads and AC power lines should be contained in rigid metal conduit, or flexible conduit. Do not place line conductors and load conductors in same conduit. Use one conduit for 3 phase input wires and another conduit for the motor leads. The conduits should be grounded to form a shield to contain the electrical noise within the conduit path. Signal wires - even ones in shielded cable should never be placed in the conduit with motor power wires.

If flexible conduit is required, the wires should be shielded twisted-pair. Although this practice gives better protection than unshielded wires, it lacks the protection offered by rigid metal conduit.

### Special Drive Situations

For severe noise situations, it may be necessary to reduce transient voltages in the wires to the motor by adding load reactors. Load reactors are installed between the control and motor.

Reactors are typically 3% reactance and are designed for the frequencies encountered in PWM drives. For maximum benefit, the reactors should be mounted in the drive enclosure with short leads between the control and the reactors. Baldor can deliver line and load reactors that will reduce ripple current and improve motor life.

### Control Enclosures

Motor controls mounted in a grounded enclosure should also be connected to earth ground with a separate conductor to ensure best ground connection. Often grounding the control to the grounded metallic enclosure is not sufficient. Usually painted surfaces and seals prevent solid metallic contact between the control and the panel enclosure. Likewise, conduit should never be used as a ground conductor for motor power wires or signal conductors.

### Special Motor Considerations

Motor frames must also be grounded. As with control enclosures, motors must be grounded directly to the control and plant ground with as short a ground wire as possible. Capacitive coupling within the motor windings produces transient voltages between the motor frame and ground. The severity of these voltages increases with the length of the ground wire. Installations with the motor and control mounted on a common frame, and with heavy ground wires less than 10 ft. long, rarely have a problem caused by these motor-generated transient voltages.

Sometimes motor frame transient voltages are capacitively coupled to feedback devices mounted on the motor shaft. To prevent this problem, add electrical isolation between the motor and the feedback device. The most simple isolation method, shown in Figure 5-2, has two parts: 1) A plate of electrical insulating material placed between the motor mounting surface and the feedback device. 2) An insulating coupling between motor shaft and the shaft of the feedback device.

**Figure 5-2 Isolated Mounting Method**

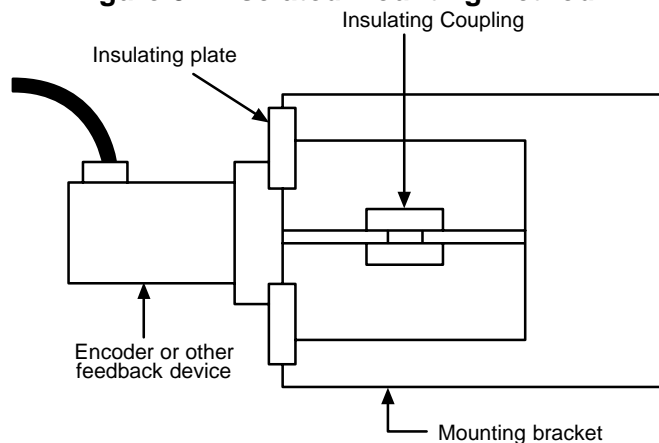

## Section 6

# Manual Tuning the Series 22H Control

---

**Manually Tuning the Control** In some applications the drive cannot be accurately auto-tuned in an application. In these cases it is necessary to calculate the values needed to tune the drive and manually enter these calculated parameter values.

**Motor Mag Amps Parameter** This parameter is located in the Level 2, Motor Data Block. This parameter is normally entered using the nameplate data (motor no load amps) or auto-tuned. If no other data is available, set Motor Mag Amps parameter to about 40% of the motor rated current stated on the nameplate.

The following procedure should be used for setting the Motor Mag Amps parameter with the motor coupled to the load:

1. Adjust the Motor Mag Amps Parameter to 40% of the motor nameplate full load current rating.
2. Give the controller a speed command input of 80% of the Base Speed on motor nameplate.
3. Select motor voltage on keypad display by pressing the DISP key until the motor voltage value is displayed.
4. Observe the motor voltage. Ideally, it should read 80% of motor nameplate voltage. By raising the Motor Mag Amps parameter value, the motor voltage will raise proportionally. Continuing to raise the Motor Mag Amps parameter value will eventually saturate the motor voltage. By lowering the Motor Mag Amps parameter value, the motor voltage will lower proportionally.
5. While the motor is running adjust the Motor Mag Amps parameter until the display indicates the proper voltage (80% of motor rated).

**Slip Frequency Parameter** This parameter is located in the Level 1, Vector Control Block. The slip frequency may be calculated from nameplate data or auto tuned.

$$F_{\text{slip}} = \text{Rated Freq} - \left[ \frac{(\text{Rated RPM} \times \text{Number of Motor Poles})}{120} \right] \text{ OR}$$

$$F_{\text{slip}} = \text{Rated Freq} - \left( \frac{\text{Base Speed}}{\text{Sync Speed}} \right) (\text{Rated Freq})$$

**Current Prop Gain Parameter** This parameter is located in the Level 1, Vector Control Block. The Current Prop Gain parameter is normally auto-tuned when motor inductance is not known. Where auto-tuning can't be used, the proper manual setting for the proportional gain can be calculated by:

$$\text{Current PROP Gain} = \frac{[740 \times L \times (A/V)]}{\text{VAC}}$$

Where:

L = Line to neutral leakage inductance of the motor in mH

VAC = Nominal line Volts

A/V = The Amps/Volt scaling of the current feedback

Motor line to neutral leakage inductance can be obtained either from the motor manufacturer or by measuring the line-to-line inductance and dividing by two.

The A/V scaling for the controller can be found in the diagnostic information located in the DISPLAY MODE.

For most applications setting the Current Prop Gain parameter to a value of 20 will yield adequate performance.

---

### Current Int Gain Parameter

The Current Int Gain parameter located in the Level 1 Vector Control Block is factory preset at 150 Hz. This setting is suitable for essentially all systems. **DO NOT CHANGE WITHOUT FACTORY APPROVAL.**

### Speed Prop Gain Parameter

The Speed Prop Gain parameter located in the Level 1 Vector Control Block is factory set to 10. This gain may be increased or decreased to suit the application. Increasing the Speed Prop Gain parameter will result in faster response, excessive proportional gain will cause overshoot and ringing. Decreasing the Speed Prop Gain parameter will cause slower response and decrease overshoot and ringing caused by excessive proportional gain.

### Speed Int Gain Parameter

The Speed Int Gain parameter located in the Level 1 Vector Control Block is set to 1 Hz and may be set at any value from zero to 9.99 Hz. See also, PI Controller later in this section.

Setting the Speed Int Gain parameter to 0Hz removes integral compensation that results in a proportional rate loop. This selection is ideal for systems where overshoot must be avoided and substantial stiffness (ability of the controller to maintain commanded speed despite varying torque loads) isn't required.

Increasing values of the Speed Int Gain parameter increases the low frequency gain and stiffness of the controller, an excessive integral gain setting will cause overshoot for transient speed commands and may lead to oscillation. Typical setting is 4 Hz. If the Speed Prop Gain parameter and the Speed Int Gain parameter are set too high, an overshoot condition can also occur.

To manually tune the control, the following procedure is used:

1. Set the speed Int Gain parameter = 0 (remove integral gain).
2. Increase the Speed Prop Gain parameter setting until adequate response to step speed commands is attained.
3. Increase the Speed Int Gain parameter setting to increase the stiffness of the drive or its' ability to maintain speed with dynamic load changes.

Note: It is convenient to monitor speed step response with a strip chart recorder or storage oscilloscope connected to J1-6 or -7 with Level 1, Output Block Analog Out #1 or #2 set to ABS SPEED, 0 VDC = zero speed. See Section 3 for a discussion of analog outputs.

---

## PI Controller

Both the current and rate control loops are of the Proportional plus Integral type. If "E" is defined to be the error signal,

$$E = \text{Command} - \text{Feedback}$$

then the PI controller operated on "E" as

$$\text{Output} = (K_p * E) + (K_i \int E dt)$$

where  $K_p$  is the proportional gain of the system and  $K_i$  is the integral gain of the system.

The transfer function (output /E) of the controller using 1/s (Laplace Operator) to denote the integral,

$$\text{Output}/E = K_p + K_i / s = K_p (s + K_i/K_p) / s.$$

The second equation shows that the ratio of  $K_i/K_p$  is a frequency in radians/sec. In the Baldor Series 22H AC Vector Control, the integral gain has been redefined to be,

$$K_i = (K_i / K_p) / (2\pi) \text{ Hz},$$

and the transfer function is,

$$\text{Output}/E = K_p (s + 2\pi K_i) / s.$$

This sets the integral gain as a frequency in Hz. As a rule of thumb, set this frequency about 1/10 of the bandwidth of the control loop.

The proportional gain sets the open loop gain of the system, the bandwidth (speed of response) of the system. If the system is excessively noisy, it is most likely due to the proportional gain being set too high.





## Section 7

# Specifications, Ratings & Dimensions

---

### Specifications:

Horsepower	10-50 HP @ 230VAC 10-450 HP @ 460VAC
Input Frequency	50/60 HZ $\pm$ 5% Note: 50Hz operation requires a 15% control derating.
Output Voltage	0 to Maximum Input VAC
Output Current	See Ratings Table
Service Factor	1.0
Duty	Continuous
Overload Capacity	Constant Torque Mode: 170-200% for 3 secs 150% for 60 secs Variable Torque Mode: 115% for 60 secs
Speed Command Potentiometer	5k or 10k ohm, 0.5 watt

### Operating Conditions:

Voltage Range: 230 VAC Models 460 VAC Models	180-264 VAC 3 $\phi$ 60 Hz / 180-230 VAC 3 $\phi$ 50 Hz 340-528 VAC 3 $\phi$ 60 Hz / 340-460 VAC 3 $\phi$ 50 Hz Note: 50Hz operation requires a 15% control derating.
Input Line Impedance:	3% minimum
Ambient Operating Temperature:	10 to +40 °C Derate Output 2% per °C over 40 °C to 55 °C Max
Rated Storage Temperature:	- 30 °C to +65 °C
Enclosure:	NEMA 1: EL (suffix) Control Module NEMA 1: EK (suffix) Control Module NEMA 1: EK (suffix) Filter Assembly Open Chassis: EK 12% Boost Regulator 3% Line Reactor
Humidity:	NEMA 1: 10 to 90% RH Non-Condensing
Altitude:	Sea level to 3300 Feet (1000 Meters) Derate 2% per 1000 Feet (303 Meters) above 3300 Feet
Shock:	1G
Vibration:	0.5G at 10Hz to 60Hz

### Keypad Display:

Display	Backlit LCD Alphanumeric 2 Lines x 16 Characters
Keys	12 key membrane with tactile response
Functions	Output status monitoring Digital speed control Parameter setting and display Diagnostic and Fault log display Motor run and jog Local/Remote toggle
LED Indicators	Forward run command Reverse run command Stop command Jog active
Remote Mount	100 feet (30.3m) max from control

---

## Control Specifications:

Control Method	PWM
Velocity Loop Bandwidth	Adjustable to 180 Hz
Current Loop Bandwidth	Adjustable to 1200 Hz
Maximum Output Frequency	500 Hz
Standard Frequency Version	Full rating 1-2.5 KHz PWM frequency, Adjustable to 5 KHz with linear derating (between 2.5 - 5KHz) by 10% at 5 KHz
Quiet Frequency Version	Full rating 1-8 KHz PWM frequency, Adjustable to 16 KHz with linear derating (between 8 - 16KHz) by 30% at 16 KHz
Selectable Operating Modes	Keypad Standard 3 Wire Control 15 Speed Two Wire Control 3 Speed, 2 Wire Control 3 Speed, 3 Wire Control Bipolar Speed/Torque Control Serial Process Control EPOT, 2 Wire Control EPOT, 3 Wire Control

## Differential Analog Input:

Common Mode Rejection	40 db
Full Scale Range	$\pm 5\text{VDC}$ , $\pm 10\text{VDC}$ , 4-20 mA
Resolution	9 bits + sign

## Other Analog Input:

Full Scale Range	0 - 10 VDC
Resolution	9 bits + sign

## Analog Outputs:

Analog Outputs	2 Assignable
Full Scale Range	0 - 5 VDC
Source Current	1 mA maximum
Resolution	8 bits

---

## Digital Inputs:

Opto-isolated Logic Inputs	9 Assignable
Rated Voltage	10 - 30 VDC (closed contacts std)
Input Impedance	6.8 K Ohms
Leakage Current	10 $\mu$ A maximum

## Digital Outputs:

Opto-isolated Logic Outputs	4 Assignable
ON Current Sink	50 mA Max
ON Voltage Drop	2 VDC Max
Maximum Voltage	30 VDC

## Diagnostic Indications:

### Inverter Section:

Current Sense Fault	Over speed	New Base ID	DC Bus High
Ground Fault	Lost User Data	Torque Proving	DC Bus Low
Over Current FLT	Soft Start Fault	Following Error	External Trip
Overload - 3 sec	No EXB Installed	Encoder Loss	Int. Overtemp
Low INIT Bus Volts	Ready	Logic Supply Fault	Invalid Base ID
Microprocessor Reset	Memory Errors	Power Base Fault	Inverter Base ID
Over temperature (Motor or Control)	Overload - 1 min	Line REGEN Fault	Resolver Loss
User Text Fault			

### Converter Section:

Current Sense Fault	Invalid Base ID	DC Bus Low Fault
GND Fault	ID No Feedback	High Initial Current Fault
Over Current Fault	Power Base Fault	Lost AB Phase
Overload Fault	Lost User Data	Lost BC Phase
New Base ID	DC Bus High	Low Init Bus Volts
Microprocessor Reset	Sync to Line Fault	Memory Error
Int Over temperature	Logic Supply Fault	

## Series 22H Vector Control Ratings

CATALOG NO.	INPUT VOLT	ENCLOSURE SIZE	STANDARD 2.5 kHz PWM								QUIET 8.0 kHz PWM							
			CONSTANT TORQUE				VARIABLE TORQUE				CONSTANT TORQUE				VARIABLE TORQUE			
			HP	KW	IC	IP	HP	KW	IC	IP	HP	KW	IC	IP	HP	KW	IC	IP
ZD22H210-EL	230	C+	10	7.4	28	56	10	7.4	28	32	10	7.4	28	48	10	7.4	28	32
ZD22H215-EL	230	C+	15	11.1	42	84	15	11.1	42	48	10	7.4	30	61	15	11.1	42	48
ZD22H220-EL	230	C+	20	14.9	55	100	20	14.9	55	62	15	11.1	42	92	20	14.9	54	62
ZD22H225-EL	230	C+	25	18.6	68	116	25	18.6	68	78	20	14.9	54	92	25	18.6	68	78
ZD22H230-EL	230	D+	30	22.3	80	140	30	22.3	80	92	25	18.6	70	122	30	22.3	80	92
ZD22H240-EL	230	D+	40	29.8	105	200	40	29.8	105	120	30	22.3	80	160	40	29.8	104	120
ZD22H250-EL	230	D+	50	37.2	130	225	50	37.2	130	150	40	29.8	105	183	50	37.2	130	150
ZD22H410-EL	460	C+	10	7.4	15	30	10	7.4	15	17	7.5	5.5	11	22	10	7.4	15	17
ZD22H415-EL	460	C+	15	11.1	21	36	15	11.1	21	24	10	7.4	15	30	15	11.1	21	24
ZD22H420-EL	460	C+	20	14.9	27	54	20	14.9	27	31	15	11.1	21	46	20	14.9	27	31
ZD22H425-EL	460	C+	25	18.6	34	58	25	18.6	34	39	20	14.9	27	46	25	18.6	34	39
ZD22H430-EL	460	D+	30	22.3	40	70	30	22.3	40	46	25	18.6	35	61	30	22.3	40	46
ZD22H440-EL	460	D+	40	29.8	55	100	40	29.8	55	63	30	22.3	40	80	40	29.8	52	60
ZD22H450-EL	460	D+	50	37.2	65	115	50	37.2	65	75	40	29.8	55	92	50	37.2	65	75
ZD22H460-EK	460	D	60	44.7	80	140	60	44.7	80	92	50	37.2	65	122	60	44.7	80	92
ZD22H475-EK	460	E	75	56	100	170	75	56	100	115	60	44.7	80	140	75	56	100	115
ZD22H4100-EK	460	E	100	75	125	220	100	75	125	144	75	56	100	180	100	75	125	144
ZD22H4150-EK	460	F	150	112	190	380	150	112	190	220	125	93	150	260	150	112	170	200
ZD22H4200-EK	460	F	200	149	250	500	200	149	250	290	150	112	190	380	175	131	210	240
ZD22H4250-EL	460	G+	250	187	310	620	250	187	310	356								
ZD22H4300-EL	460	G+	300	224	370	630	300	224	370	425								
ZD22H4350-EL	460	G+	350	261	420	720	350	261	420	480								
ZD22H4400-EL	460	G+	400	298	480	820	400	298	480	552								
ZD22H4450-EL	460	G+	450	336	540	920	450	336	540	620								

IC = Continuous Output Current (in Amps)  
 IP= Peak Output Current (in Amps)  
 EL= NEMA 1 enclosure  
 EK= Control, filter, and boost regulator shipped separately. Control and filter in NEMA1 enclosure.  
 Boost regulator and 3% line reactor are open chassis.

PWM Frequency Continuous and Peak Current Derating:  
 2.5KHz Ratings - Full rating from 1 - 2.5KHz  
 Adjustable from 1 - 5KHz with linear derating to 90% current rating at 5KHz  
 8.0KHz Ratings - Full rating from 1 - 8.0KHz  
 Adjustable from 1 - 16KHz with linear derating to 70% current rating at 16KHz

 Custom Order.

 Not Available.

**Table 7-6 Matched Component Matrix**

Control Catalog No.	Control Specification No.	230 VAC 3% Line Reactor Catalog No.	380-415 VAC 4% Line Reactor Catalog No.	460 VAC 3% Line Reactor Catalog No.	Boost Regulator Specification No.	Filter Specification No.
ZD22H210-EL	VE0574A00	LRAC03501			<b>Included in "EL" Suffix Catalog Numbers</b>	
ZD22H215-EL	VE0575A00	LRAC04501				
ZD22H220-EL	VE0576A00	LRAC05501				
ZD22H225-EL	VE0577A00	LRAC08001				
ZD22H230-EL	VE0568A00	LRAC08001				
ZD22H240-EL	VE0569A00	LRAC10001				
ZD22H250-EL	VE0570A00	LRAC13001				
ZD22H410-EL	VE0565A00		LRAC01802	LRAC01802	<b>Included in "EL" Suffix Catalog Numbers</b>	
ZD22H415-EL	VE0082A00		LRAC02502	LRAC02502		
ZD22H420-EL	VE0088A00		LRAC03502	LRAC03502		
ZD22H425-EL	VE0090A00		LRAC04502	LRAC03502		
ZD22H430-EL	VE0092A00		LRAC04502	LRAC04502		
ZD22H440-EL	VE0094A00		LRAC05502	LRAC05502		
ZD22H450-EL	VE0096A00		LRAC08002	LRAC08002		
ZD22H460-EK	VE0097A00		LRAC08002	LRAC08002	V2080709	LF1015
ZD22H475-EK	VE0099A00		LRAC10002	LRAC10002	V2080710	LF1015
ZD22H4100-EK	VE0077A00		LRAC13002	LRAC13002	V2080711	LF1015
ZD22H4150-EK	VE0079A00		LRAC25003	LRAC20002	V2080712	LF2015
ZD22H4200-EK	VE0084A00		LRAC32003	LRAC25002	V2080713	LF2015
ZD22H4250-EL	VE0671A00		LRAC32002	LRAC32002	<b>Included in "EL" Suffix Catalog Numbers</b>	
ZD22H4300-EL	VE0631A00		LRAC40002	LRAC40002		
ZD22H4350-EL	VE0632A00		LRAC50002	LRAC50002		
ZD22H4400-EL	VE0633A00		LRAC60002	LRAC50002		
ZD22H4450-EL	VE0634A00		LRAC75003	LRAC60002		

 Included in EL Suffix Control Catalog Number.

 Not applicable.

Note: Line reactor, boost regulator, filter assembly and control must be ordered separately.

## Terminal Tightening Torque Specifications

Table 7-7 Tightening Torque Specifications

Catalog No.	Tightening Torque											
	Power TB1		Ground		Control J1		Interface J3 & L1A, L2A, L3A		Filter J1 & J2		Line Reactor	
	Lb-in	Nm	Lb-in	Nm	Lb-in	Nm	Lb-in	Nm	Lb-in	Nm	Lb-in	Nm
ZD22H210-EL	35	4	50	5.6	7	0.8						
ZD22H215-EL	35	4	50	5.6	7	0.8						
ZD22H220-EL	35	4	50	5.6	7	0.8						
ZD22H225-EL	35	4	50	5.6	7	0.8						
ZD22H230-EL	35	4	50	5.6	7	0.8						
ZD22H240-EL	35	4	50	5.6	7	0.8						
ZD22H250-EL	35	4	50	5.6	7	0.8						
ZD22H410-EL	35	4	50	5.6	7	0.8						
ZD22H415-EL	35	4	50	5.6	7	0.8						
ZD22H420-EL	35	4	50	5.6	7	0.8						
ZD22H425-EL	35	4	50	5.6	7	0.8						
ZD22H430-EL	35	4	22-26	2.5-3	7	0.8						
ZD22H440-EL	22-26	2.5-3	22-26	2.5-3	7	0.8						
ZD22H450-EL	22-26	2.5-3	22-26	2.5-3	7	0.8						
ZD22H460-EK	22-26	2.5-3	22-26	2.5-3	7	0.8	7	0.8	7	0.8	50	5.6
ZD22H475-EK	22-26	2.5-3	50	5.6	7	0.8	7	0.8	7	0.8	50	5.6
ZD22H4100-EK	140	15	50	5.6	7	0.8	7	0.8	7	0.8	50	5.6
ZD22H4150-EK	275	31	275	31	7	0.8	7	0.8	7	0.8	50	5.6
ZD22H4200-EK	275	31	275	31	7	0.8	7	0.8	7	0.8	50	5.6
ZD22H4250-EL	275	31	275	31	7	0.8						
ZD22H4300-EL	375	42	375	42	7	0.8						
ZD22H4350-EL	375	42	375	42	7	0.8						
ZD22H4400-EL	375	42	375	42	7	0.8						
ZD22H4450-EL	375	42	375	42	7	0.8						

 Not Applicable.

## Dimensions

### Size C+ Control

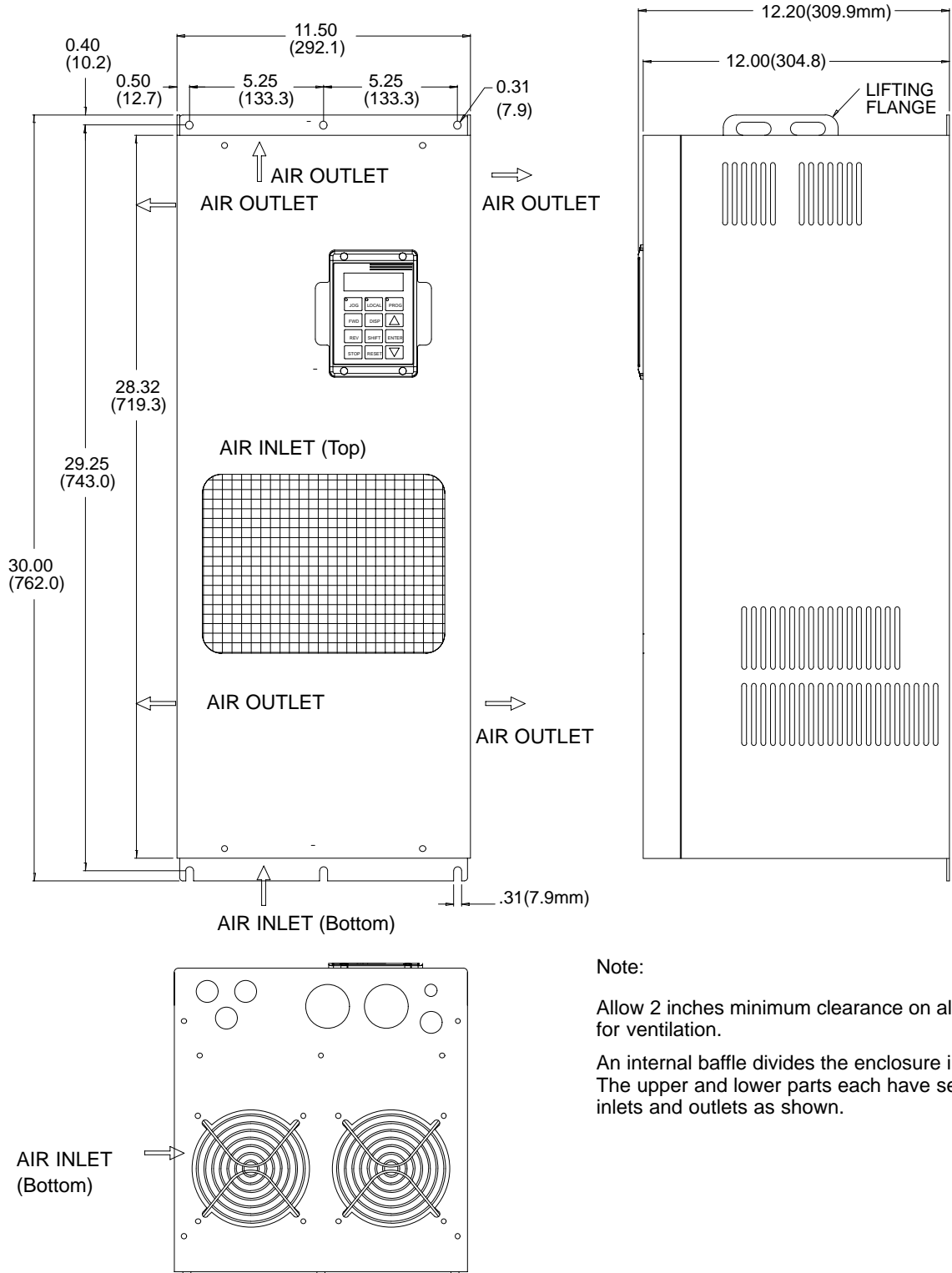



**Dimensions Continued**  
**Size D+ Control**

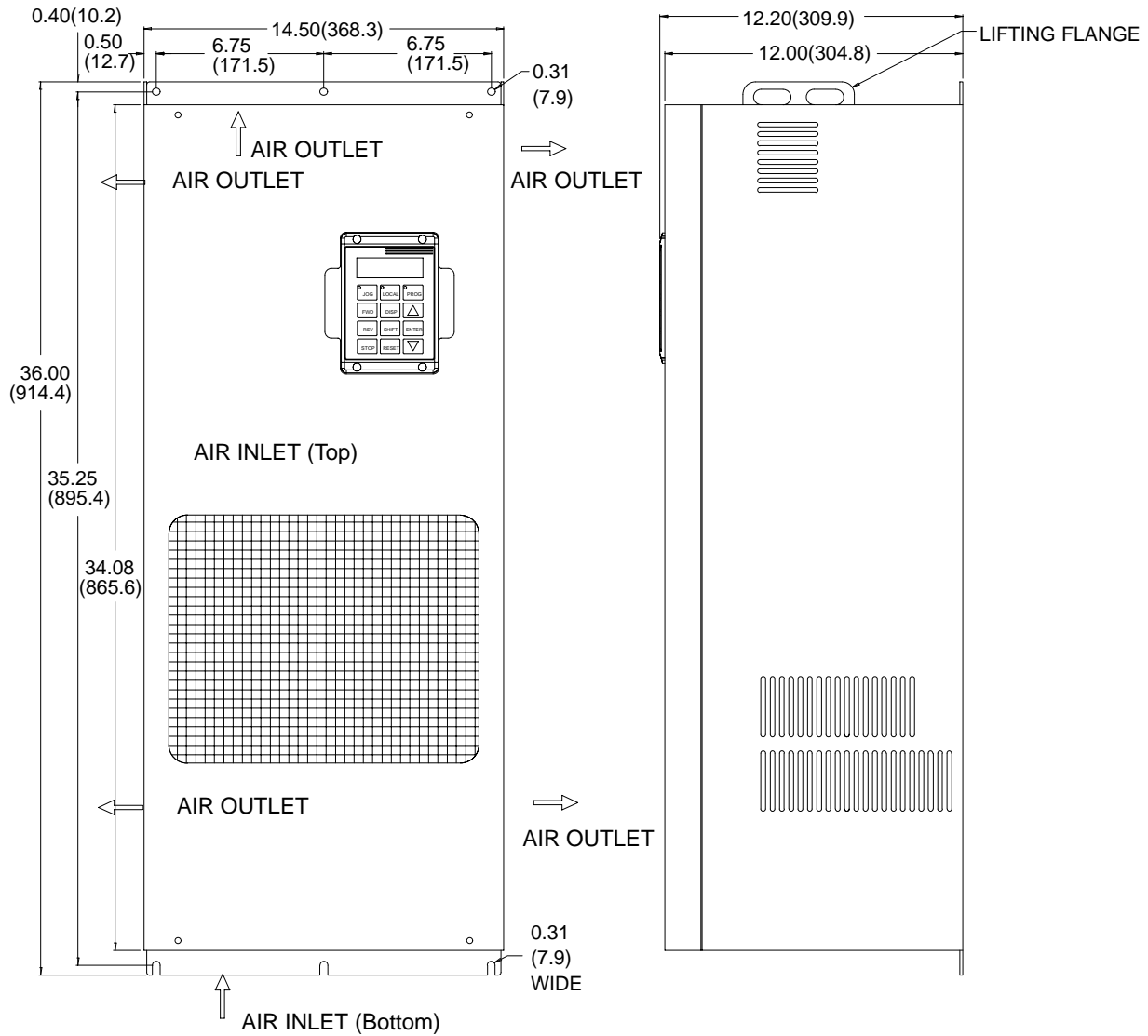

**Note:**

Allow 2 inches minimum clearance on all sides for ventilation.

An internal baffle divides the enclosure into two parts. The upper and lower parts each have separate air inlets and outlets as shown.

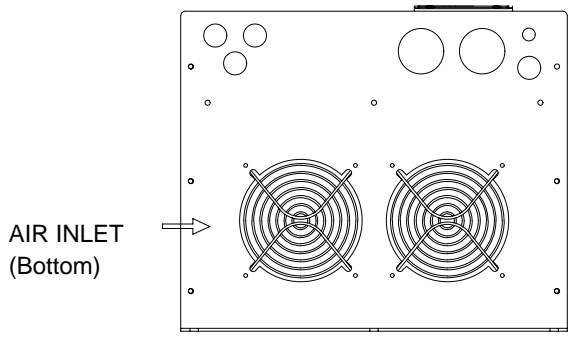

**Dimensions Continued**  
**Size D Control**

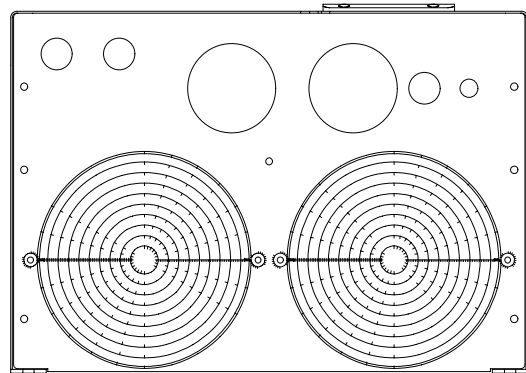
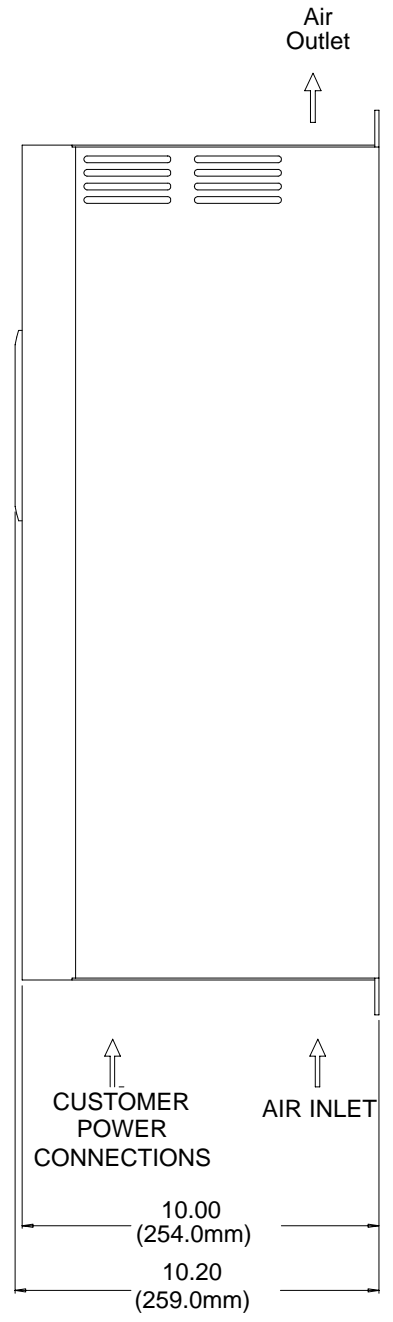
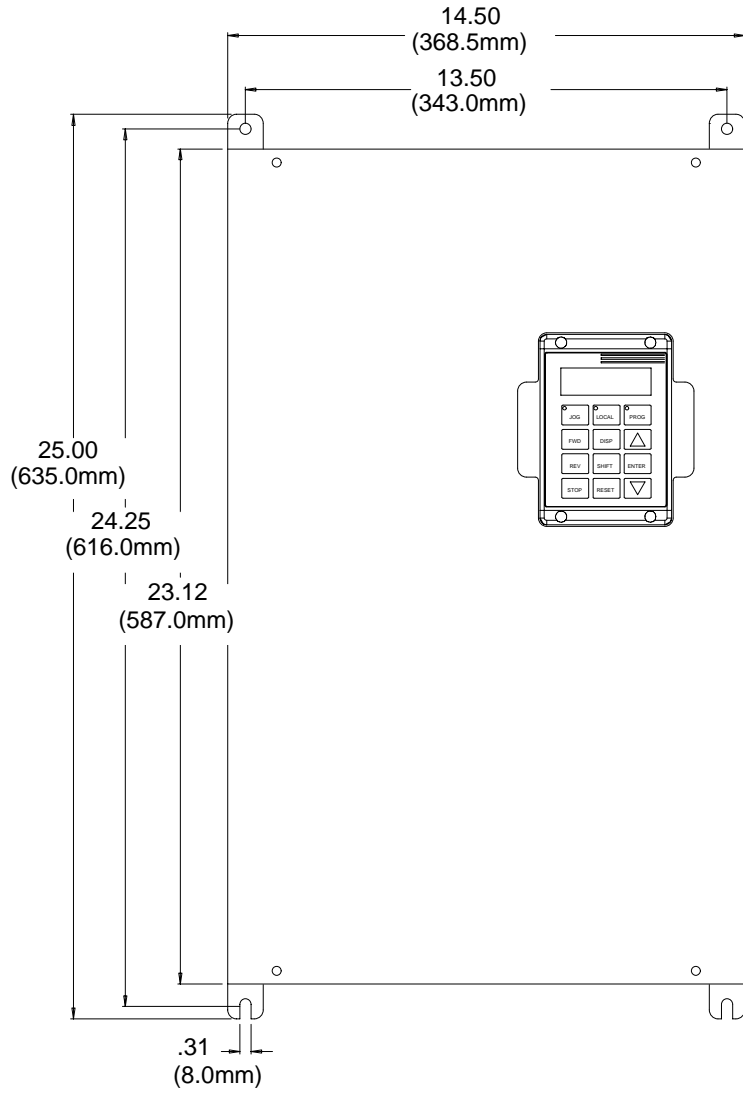



**Dimensions** Continued

**Size E Control – Through-Wall Mounting**

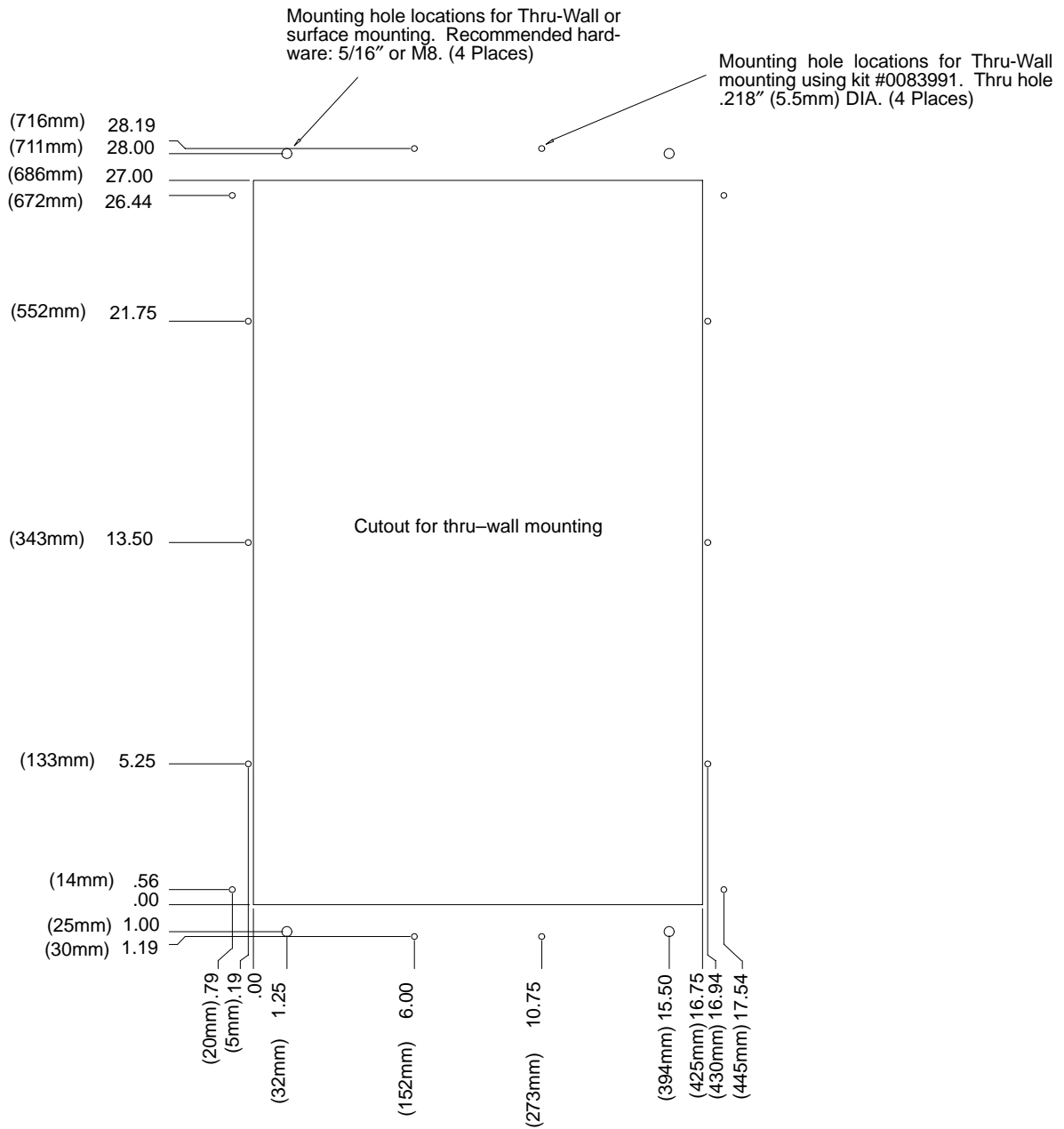

---

**Dimensions** Continued

**Size E Control – Through-Wall Mounting** Continued

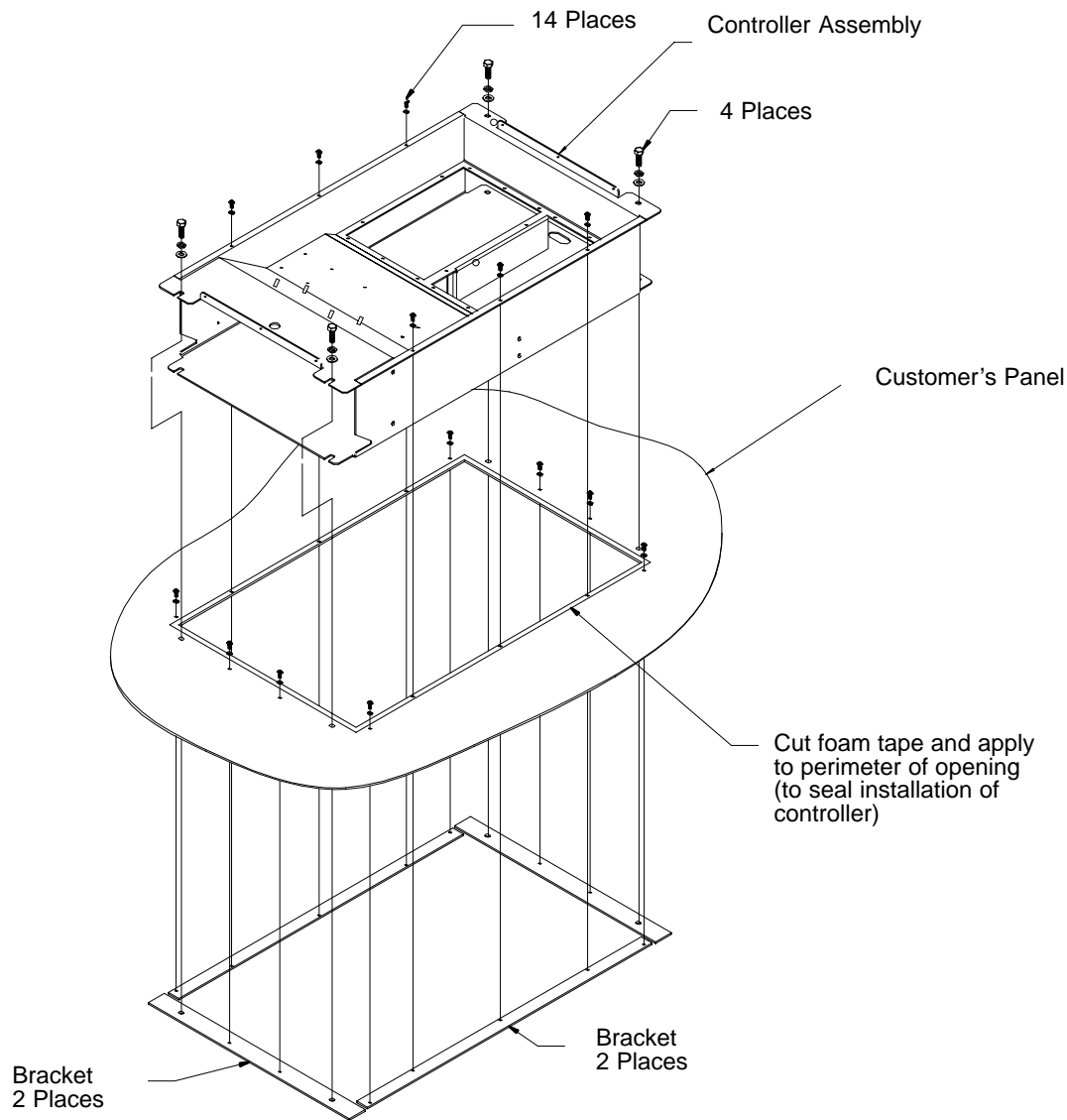

Thru-Wall Mounting Kit No. V0083991

Parts List

<b>QTY</b>	<b>Part No.</b>	<b>Description</b>
2	V1083991	Bracket, small (left & right)
2	V1083992	Bracket, Large (top & bottom)
14	V6300710	Screw, 10-32 x 5/8
14	V6420010	Lock Washer No. 10
4	V6390205	Hex Bolt 5/16-18 x 5/8
4	V6420032	Lock Washer 5/16
4	V6410132	Flat Washer 5/16
1	C6990204	Tape, Single coated vinyl – 3.0 Yards (2.74m)

**Dimensions Continued**  
**Size F Control**

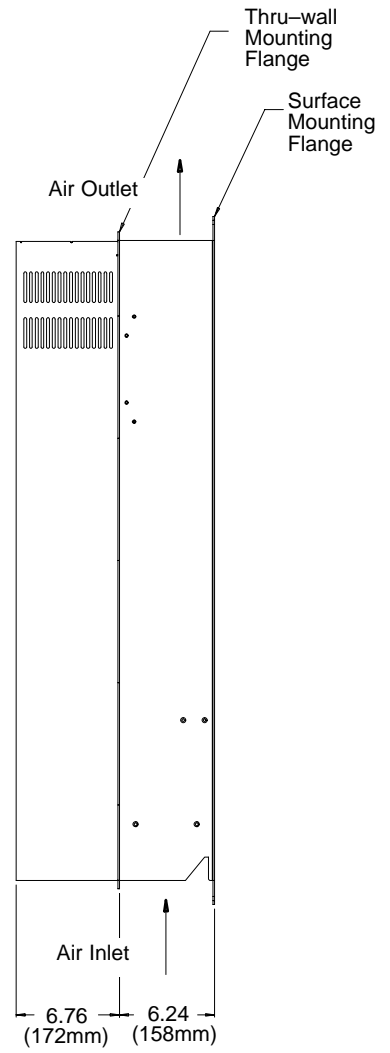
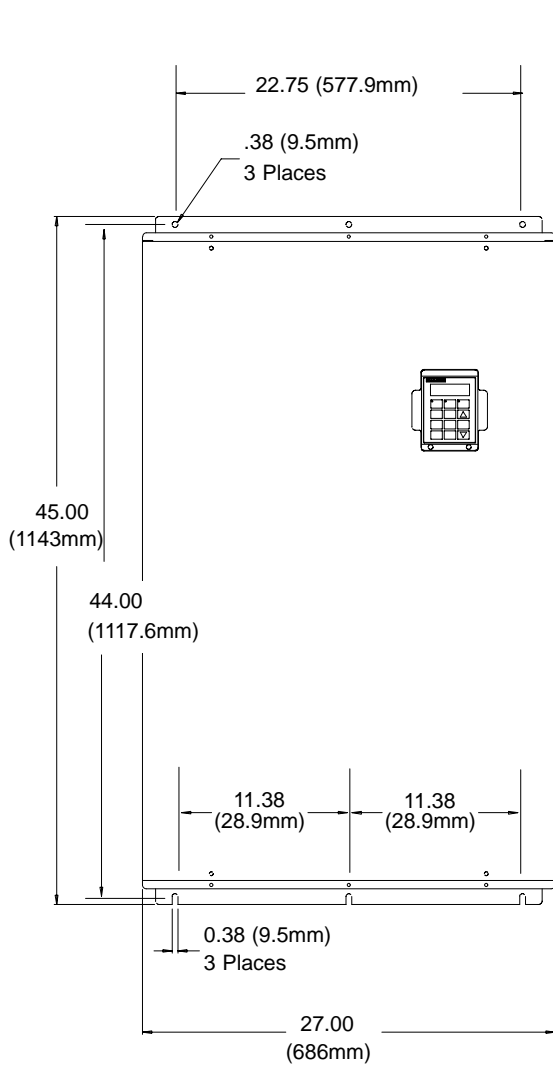

**Dimensions** Continued

**Size F Control – Through-Wall Mounting**

Mounting hole locations for Thru-Wall mounting or without thru-wall mounting kit #0084001. Thru hole .218" (5.5mm) DIA. (16 Places, coded A)

Mounting hole locations for Thru-Wall mounting using kit #0084001. Thru hole .218" (5.5mm) DIA. (18 Places, coded B)

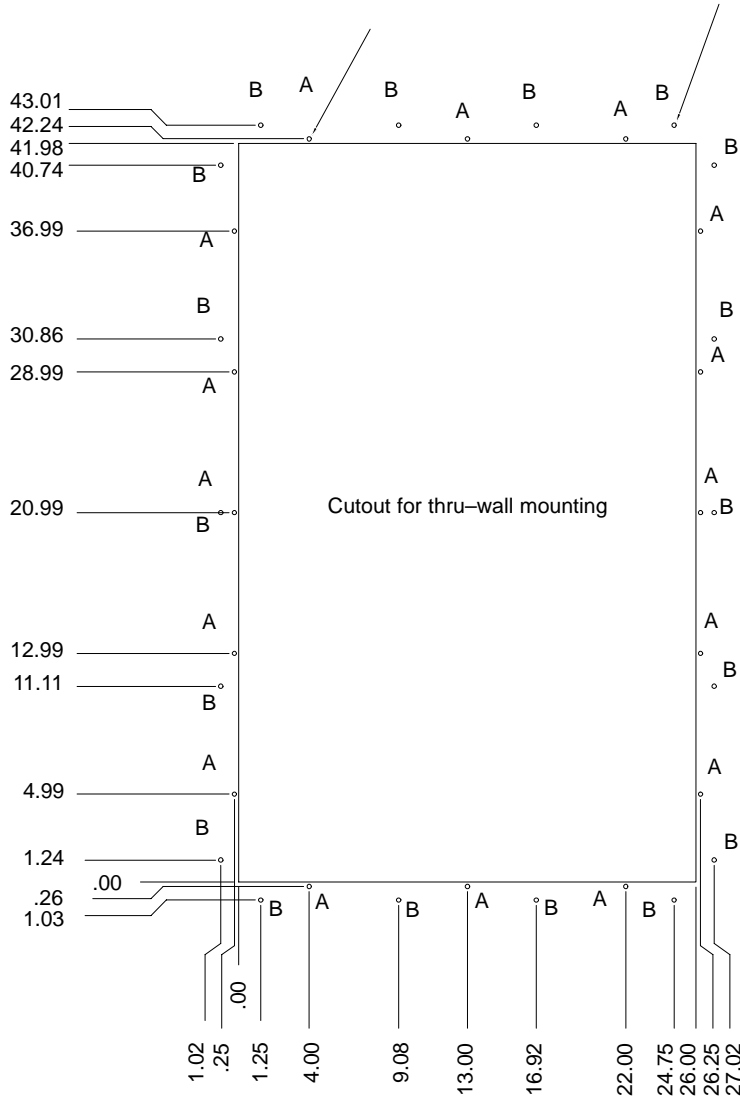

**Dimensions** Continued

**Size F Control – Through-Wall Mounting** Continued

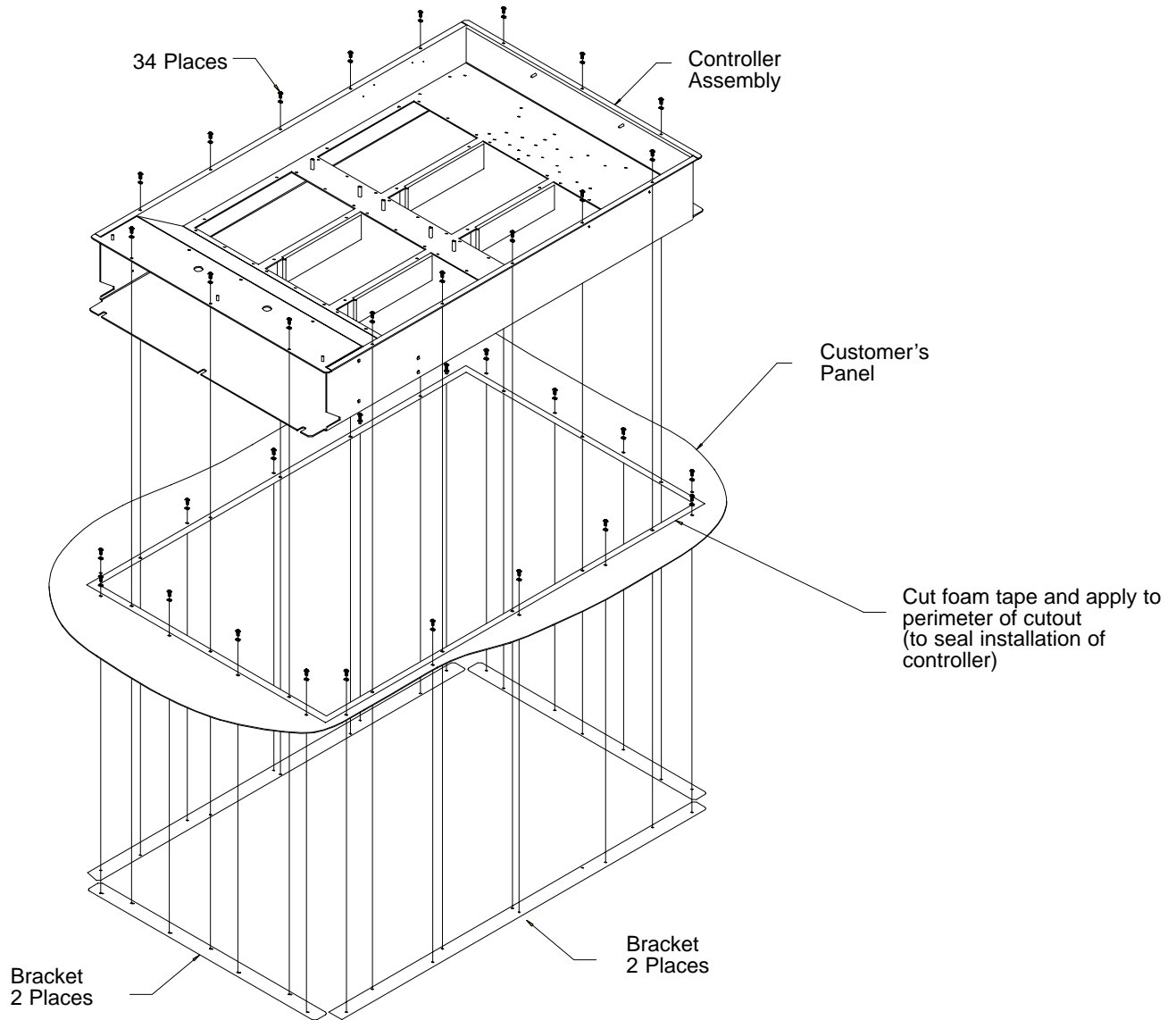

Thru-Wall Mounting Kit No. V0084001

Parts List

<b>QTY</b>	<b>Part No.</b>	<b>Description</b>
2	V1084002	Bracket, small (left & right)
2	V1084001	Bracket, Large (top & bottom)
34	V6300710	Screw, 10-32 x 5/8
34	V6420010	Lock Washer No. 10
1	C6990204	Tape, Single coated vinyl – 4.0 Yards (3.65m)



Dimensions Continued

Size G+ Control

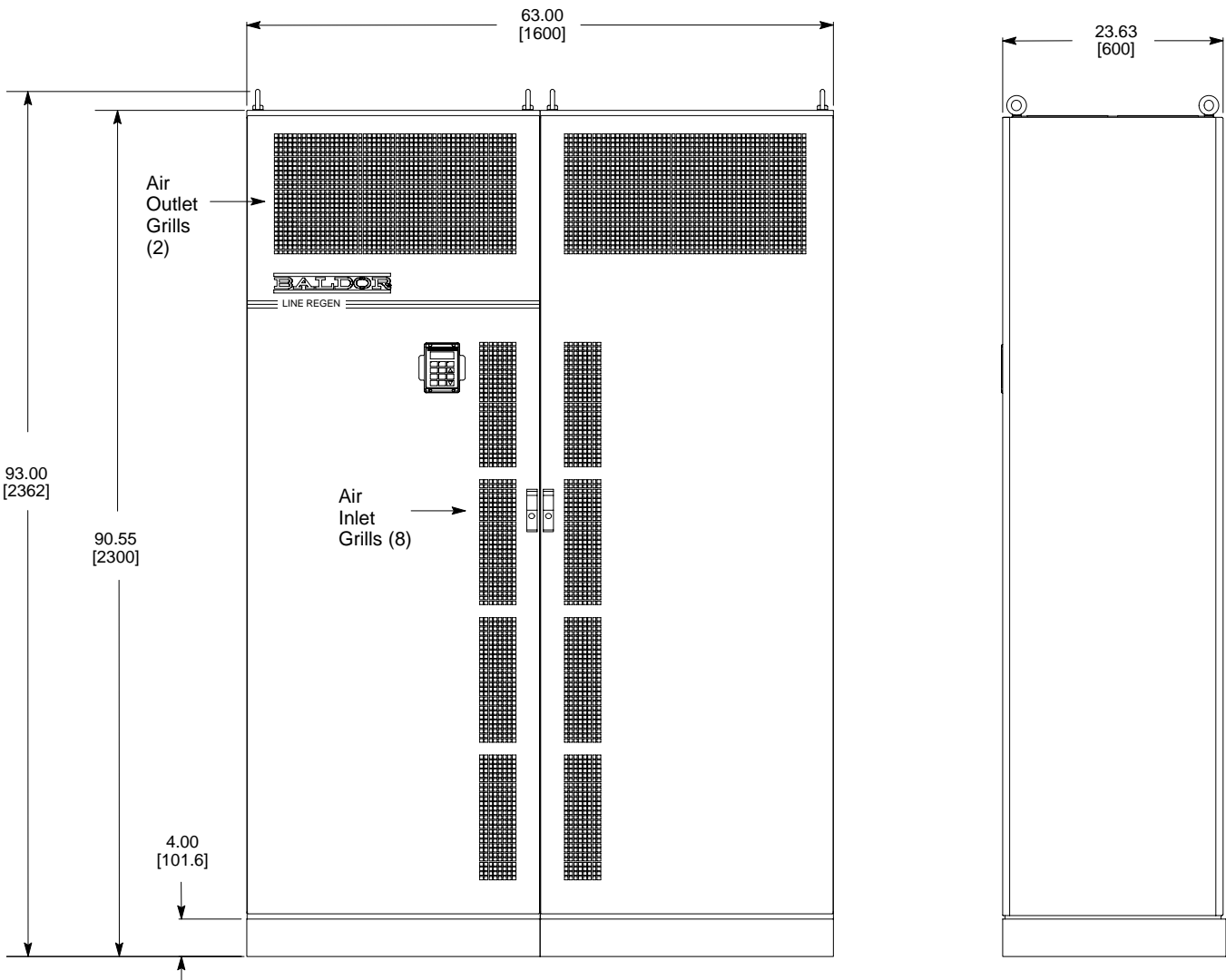
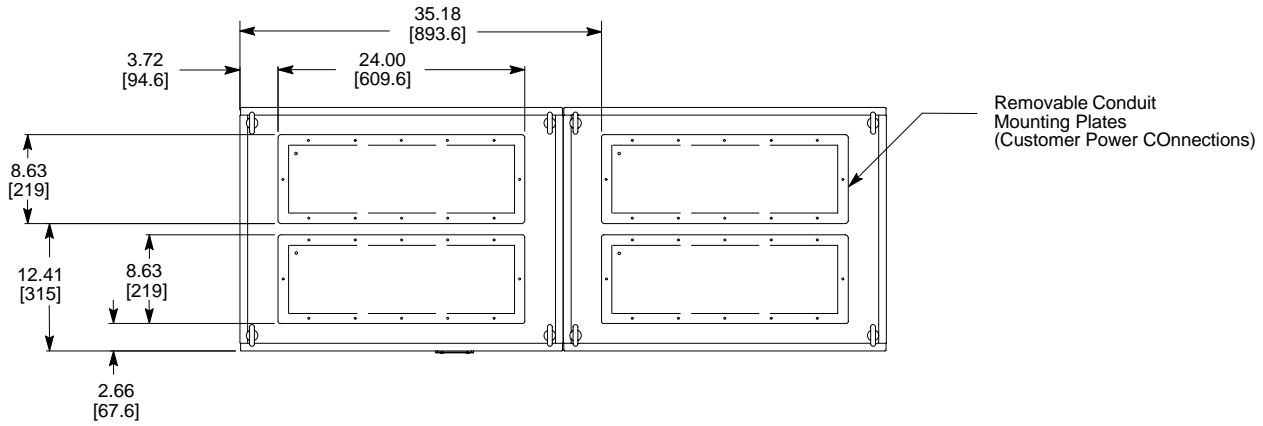

**Dimensions Continued**

**Size H Control**

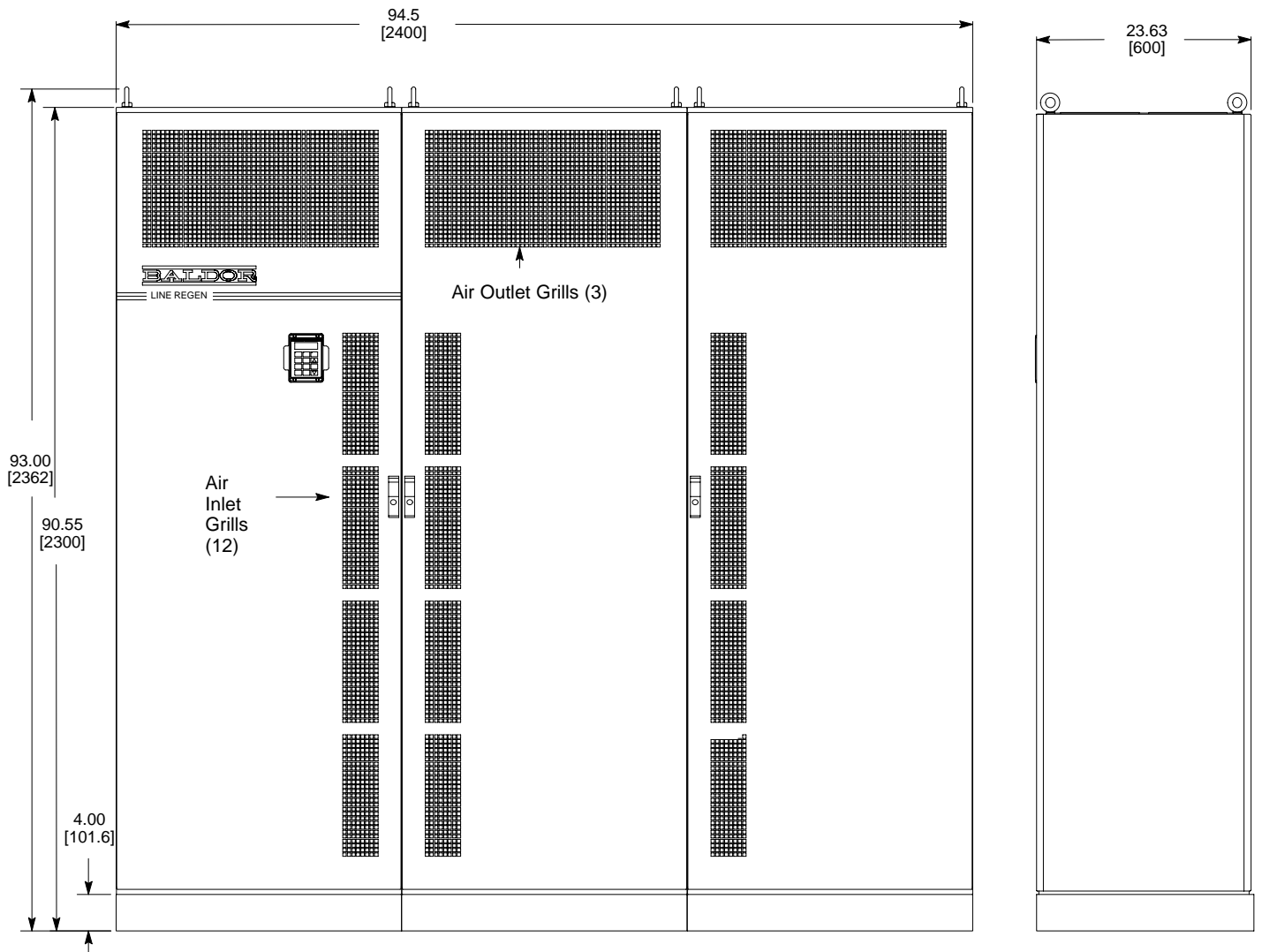
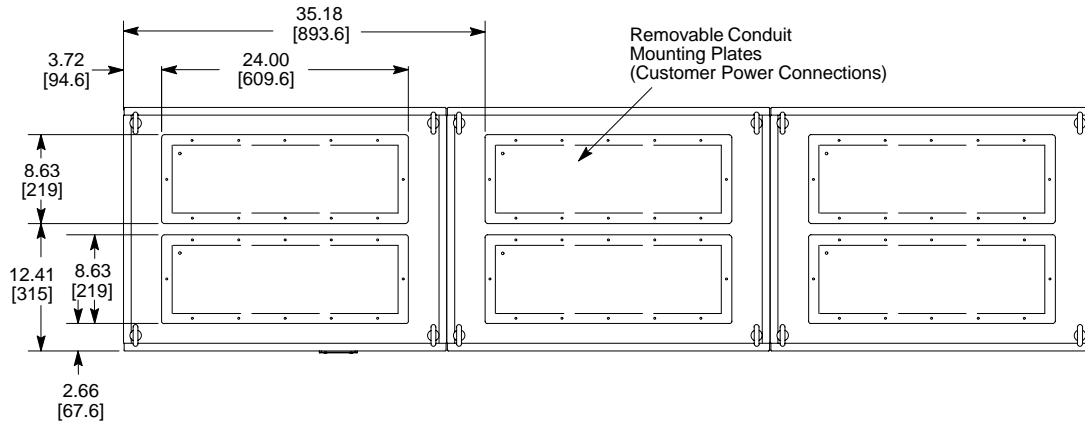

## EK Controls - Filter Assembly

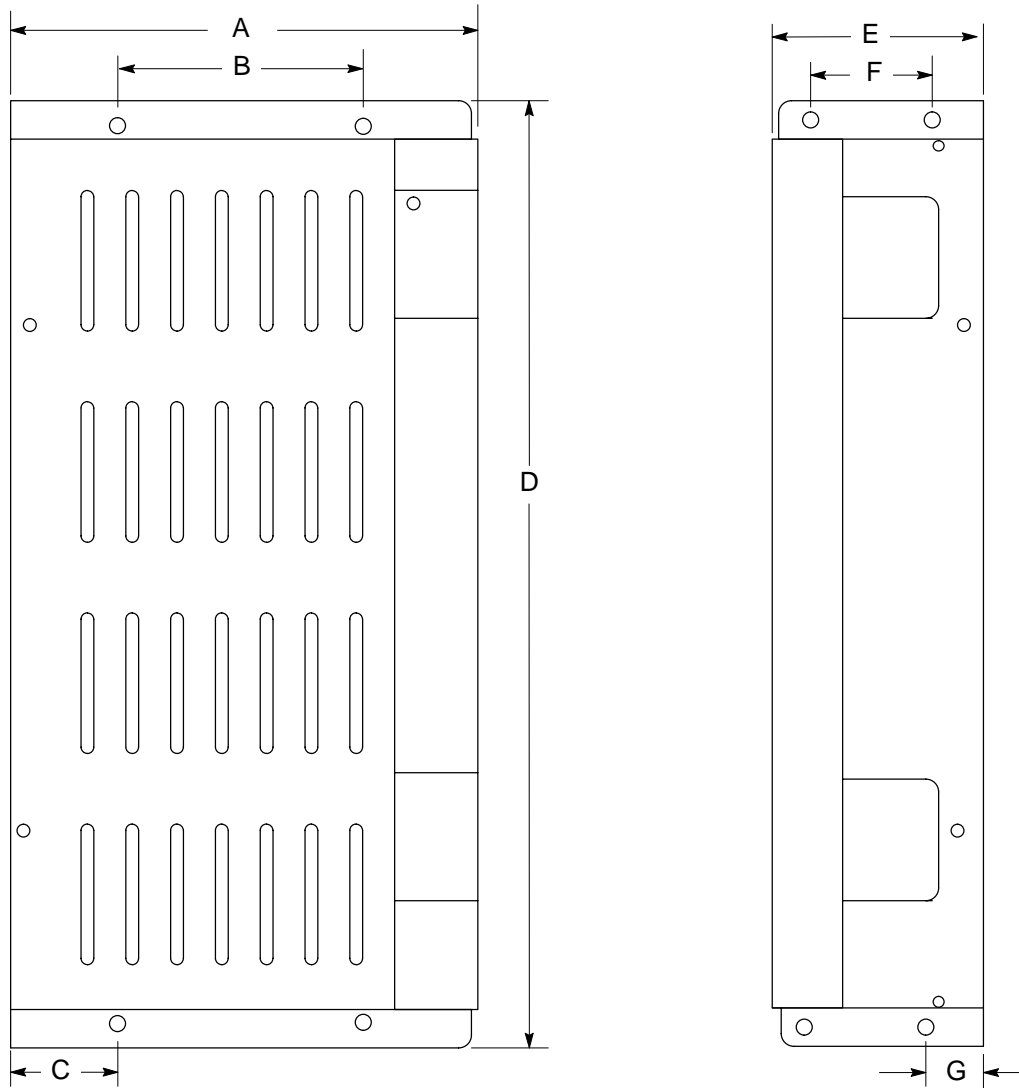

Dimension	LF1015		LF2015	
	In	mm	In	mm
A	7.75	196.9	10.25	260.3
B	4.00	101.6	5.00	127.0
C	1.81	46.0	3.31	84.1
D	15.25	387.4	18.00	457.2
E	3.52	89.4	3.65	92.7
F	2.00	50.8	2.00	50.8
G	0.92	23.3	0.92	23.3

## EK Controls - Boost Regulators

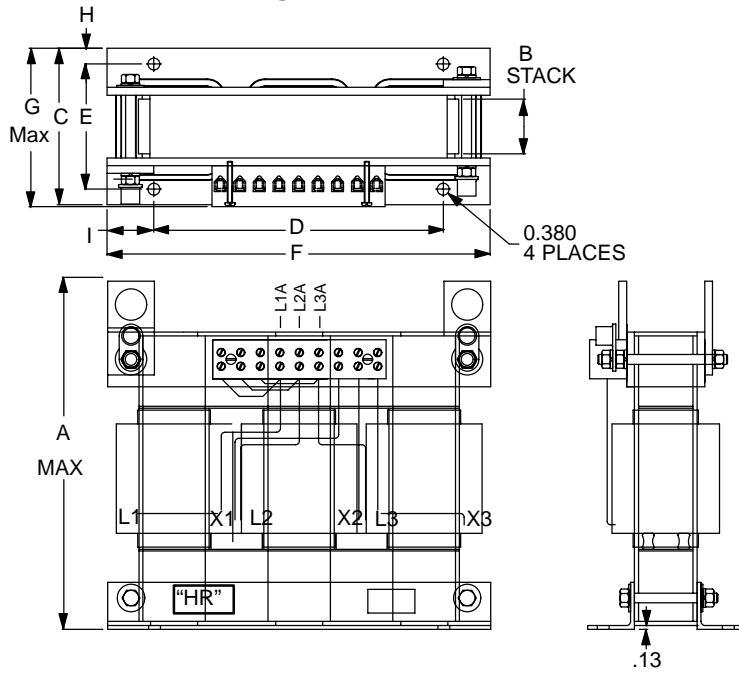

Electrical Specification/Approximate Weight					Dimensions - inches								
HP	Baldor P/N	mH	Amps	Lbs	A	B	C	D	E	F	G	H	I
60	V2080709	1.20	68	80	11.75	2.25	5.50	9.25	4.50	12.25	5.75	0.50	1.50

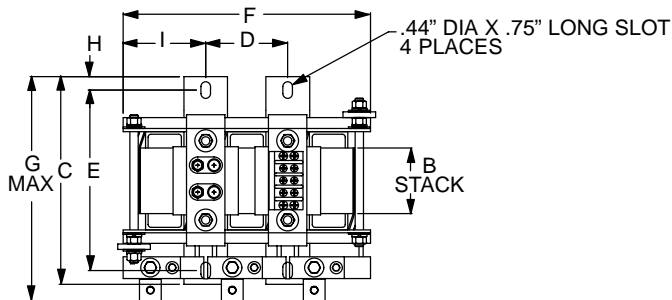

### TERMINAL BLOCK

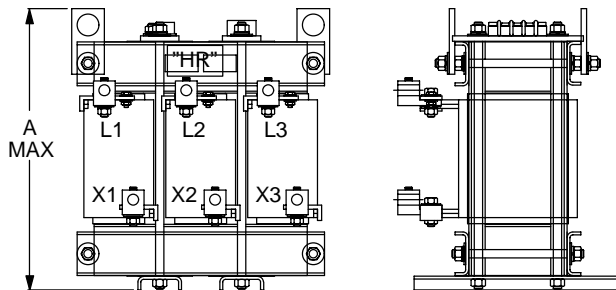
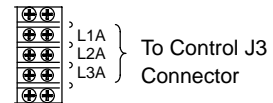

Electrical Specifications/Approximate Weight					Dimensions - inches								
HP	Baldor P/N	mH	Amps	Lbs	A	B	C	D	E	F	G	H	I
75	V2080710	1.00	85	100	13.50	3.00	9.50	3.75	8.25	11.32	10.75	0.62	3.79
100	V2080711	0.75	106	125	15.50	3.00	9.25	3.75	8.25	11.32	11.00	0.63	3.79

## EK Controls - Boost Regulators Continued

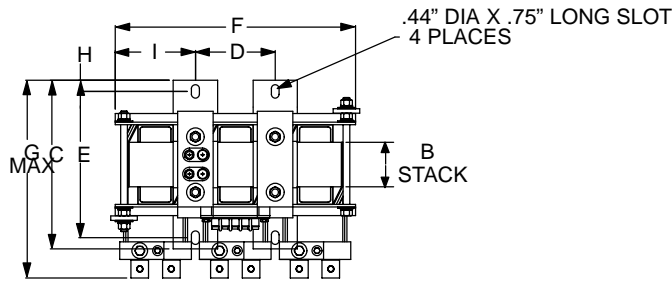

TERMINAL BLOCK

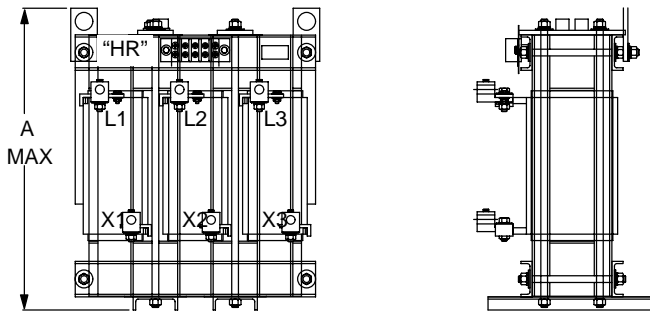
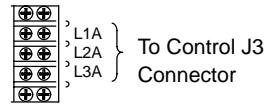

Electrical Specifications/Approximate Weight					Dimensions - inches								
HP	Baldor P/N	mH	Amps	Lbs	A	B	C	D	E	F	G	H	I
150	V2080712	0.50	162	155	18.00	2.50	9.50	4.50	8.25	13.56	12.00	0.63	4.53

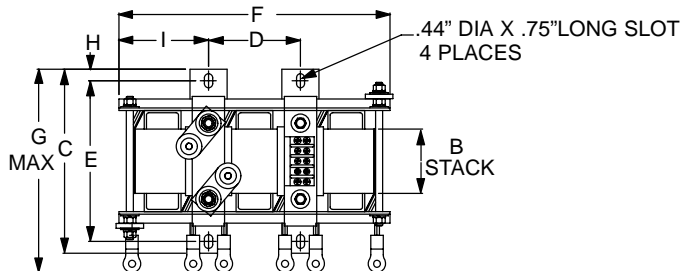

TERMINAL BLOCK

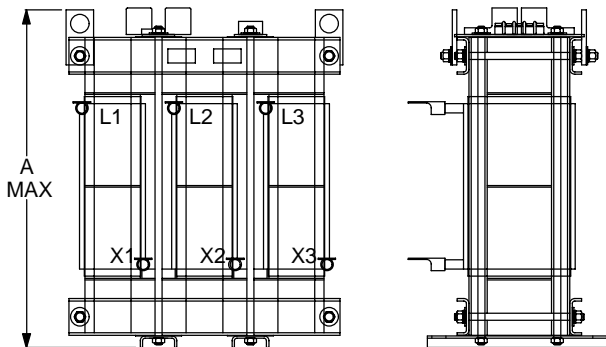
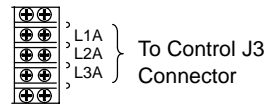

Electrical Specifications/Approximate Weight					Dimensions - inches								
HP	Baldor P/N	mH	Amps	Lbs	A	B	C	D	E	F	G	H	I
200	V2080713	0.40	213	220	19.00	3.50	10.00	5.00	8.74	14.75	11.75	0.63	4.88

# Appendix A

## Converter Section Parameter Values

Table A-1 Converter Section Parameter Block Values Level 1

Level 1 Blocks				
Block Title	Parameter	Adjustable Range	Factory Setting	User Setting
MISC	FACTORY SETTINGS	NO, YES	NO	
	LINE INDUCTOR		CALC	
	BUS CAPACITANCE	50 – 500%	100%	
	DAC SELECTION	AB BC CROSS AB CROSS DQ CONTRLR DQ CURRENTS IQ COMMAND IB AND IC Va AND Vb Ia AND Ib	AB BC CROSS	
SECURITY CONTROL	SECURITY STATE	OFF LOCAL SERIAL TOTAL	OFF	
	ACCESS TIMEOUT	0 – 600 SEC	0 SEC	
	ACCESS CODE	0 – 9999	9999	

**Power Output Section Parameter Values** (Version 3.20)

**Table A-2 Power Output Parameter Block Values Level 1**

Level 1 Blocks					
Block Title	Parameter	P#	Adjustable Range	Factory Setting	User Setting
PRESET SPEEDS	PRESET SPEED #1	1001	0-MAX Speed	0 RPM	
	PRESET SPEED #2	1002	0-MAX Speed	0 RPM	
	PRESET SPEED #3	1003	0-MAX Speed	0 RPM	
	PRESET SPEED #4	1004	0-MAX Speed	0 RPM	
	PRESET SPEED #5	1005	0-MAX Speed	0 RPM	
	PRESET SPEED #6	1006	0-MAX Speed	0 RPM	
	PRESET SPEED #7	1007	0-MAX Speed	0 RPM	
	PRESET SPEED #8	1008	0-MAX Speed	0 RPM	
	PRESET SPEED #9	1009	0-MAX Speed	0 RPM	
	PRESET SPEED #10	1010	0-MAX Speed	0 RPM	
	PRESET SPEED #11	1011	0-MAX Speed	0 RPM	
	PRESET SPEED #12	1012	0-MAX Speed	0 RPM	
	PRESET SPEED #13	1013	0-MAX Speed	0 RPM	
	PRESET SPEED #14	1014	0-MAX Speed	0 RPM	
	PRESET SPEED #15	1015	0-MAX Speed	0 RPM	
ACCEL/DECEL RATE	ACCEL TIME #1	1101	0 to 3600.0 Seconds	3.0 SEC	
	DECEL TIME #1	1102	0 to 3600.0 Seconds	3.0 SEC	
	S-CURVE #1	1103	0-100%	0 %	
	ACCEL TIME #2	1104	0 to 3600.0 Seconds	3.0 SEC	
	DECEL TIME #2	1105	0 to 3600.0 Seconds	3.0 SEC	
	S-CURVE #2	1106	0-100%	0 %	
JOG SETTINGS	JOG SPEED	1201	0-MAX Speed	200 RPM	
	JOG ACCEL TIME	1202	0 to 3600.0 Seconds	3.0 SEC	
	JOG DECEL TIME	1203	0 to 3600.0 Seconds	3.0 SEC	
	JOG S-CURVE TIME	1204	0-100%	0 %	
KEYPAD SETUP	KEYPAD STOP KEY	1301	0– REMOTE OFF (Stop key inactive during remote or serial operation). 1– REMOTE ON (Stop key active during remote or serial operation).	REMOTE ON	
	KEYPAD STOP MODE	1302	0–COAST, 1–REGEN	REGEN	
	KEYPAD RUN FWD	1303	0–OFF, 1– ON	ON	
	KEYPAD RUN REV	1304	0–OFF, 1– ON	ON	
	KEYPAD JOG FWD	1305	0–OFF, 1– ON	ON	
	KEYPAD JOG REV	1306	0–OFF, 1– ON	ON	
	LOCAL HOT START	1307	0–OFF, 1– ON	OFF	

**Table A-2 Power Output Parameter Block Values Level 1** Continued

Level 1 Blocks - Continued					
Block Title	Parameter	P#	Adjustable Range	Factory	User Setting
INPUT	OPERATING MODE	1401	1- KEYPAD 2- STANDARD RUN 3- 15SPD 4- 3SPD ANA 2WIRE 5- 3SPD ANA 3WIRE 6- SERIAL 7- BIPOLAR 8- PROCESS MODE 9- EPOT -2WIRE 10- EPOT -3WIRE	KEYPAD	
	COMMAND SELECT	1402	0- POTENTIOMETER 1- +/-10 VOLTS 2- +/-5 VOLTS 3- 4 To 20 mA 4- 10V W/TORQ FF 5- EXB PULSE FOL 6- 5VOLT EXB 7- 10 VOLT EXB 8- 4-20mA EXB 9- 3-15 PSI EXB 10- TACHOMETER EXB 11- SERIAL 12- NONE	+/-10 VOLTS	
	ANA CMD INVERSE	1403	0-OFF, 1- ON	OFF	
	ANA CMD OFFSET	1404	-20.0 TO +20.0% (where $\pm 0.5V = \pm 20\%$ )	0.0 %	
	ANA 2 DEADBAND	1405	0-10.00 V	0.00 V	
	ANA 1 CUR LIMIT	1406	0-OFF, 1- ON	OFF	
OUTPUT	OPTO OUTPUT #1	1501	0- READY 1- ZERO SPEED 2- AT SPEED 3- OVERLOAD	READY	
	OPTO OUTPUT #2	1502	4- KEYPAD CONTROL 5- AT SET SPEED 6- FAULT 7- FOLLOWING ERR 8- MOTR DIRECTION	ZERO SPEED	
	OPTO OUTPUT #3	1503	9- DRIVE ON 10- CMD DIRECTION 11- AT POSITION 12- OVER TEMP WARN	AT SPEED	
	OPTO OUTPUT #4	1504	13- PROCESS ERROR 14- DRIVE RUN 15- SERIAL	FAULT	
	ZERO SPD SET PT	1505	1-MAX Speed	200 RPM	
	AT SPEED BAND	1506	1-1000 RPM	100 RPM	
	SET SPEED	1507	0-MAX Speed	Rated Motor Speed	



**Table A-2 Power Output Parameter Block Values Level 1** Continued

Level 1 Blocks - Continued					
Block Title	Parameter	P#	Adjustable Range	Factory	User Setting
OUTPUT (Continued)	ANALOG OUT #1	1508	0- ABS SPEED 1- ABS TORQUE 2- SPEED COMMAND 3- PWM VOLTAGE 4- FLUX CURRENT 5- CMD FLUX CUR 6- LOAD CURRENT 7- CMD LOAD CUR 8- MOTOR CURRENT 9- LOAD COMPONENT 10- QUAD VOLTAGE 11- DIRECT VOLTAGE	ABS SPEED	
	ANALOG OUT #2	1509	12- AC VOLTAGE 13- BUS VOLTAGE 14- TORQUE 15- POWER 16- VELOCITY 17- OVERLOAD 18- PH2 CURRENT 19- PH3 CURRENT 20- PROCESS FDBK 21- SETPOINT CMD 22- POSITION 23- SERIAL	MOTOR CURRENT	
	ANALOG #1 SCALE	1510	10 - 100%	100%	
	ANALOG #2 SCALE	1511	10 - 100%	100%	
	POSITION BAND	1512	1-32767 CNTS	CALC	
VECTOR CONTROL	CTRL BASE SPEED	1601	1-MAX Speed	CALC	
	FEEDBACK FILTER	1602	0-7	CALC	
	FEEDBACK ALIGN	1603	0-REVERSE, 1-FORWARD	FORWARD	
	CURRENT PROP GAIN	1604	0-1000	CALC	
	CURRENT INT GAIN	1605	0-400 Hz	150 Hz	
	SPEED PROP GAIN	1606	0-1000	10	
	SPEED INT GAIN	1607	0-9.99 Hz	1.00 Hz	
	SPEED DIFF GAIN	1608	0-100	0	
	POSITION GAIN	1609	0-9999	CALC	
	SLIP FREQUENCY	1610	0-20.00 Hz	CALC	
	STATOR R1	1611	0-65.635	CALC	
	STATOR X2	1612	0-65.635	CALC	
	PROP GAIN #1	1613	0-65635	15000	
	INT GAIN #1	1614	0-65635	5000	
LEVEL 2 BLOCK	ENTERS LEVEL 2 MENU - See Table A-3.				
PRESS ENTER FOR PROGRAMMING EXIT	Exit programming mode and return to display mode.				

**Table A-3 Power Output Parameter Block Values Level 2**

Level 2 Blocks					
Block Title	Parameter	P#	Adjustable Range	Factory	User Setting
OUTPUT LIMITS	OPERATING ZONE	2001	1-STD CONST TQ 2-STD VAR TQ 3-QUIET CONST TQ 4-QUIET VAR TQ	STD CONST TQ	
	MIN OUTPUT SPEED	2002	0-MAX Speed RPM	0 RPM	
	MAX OUTPUT SPEED	2003	0-30000 RPM	Rated Motor Speed	
	PK CURRENT LIMIT	2004	0-PEAK RATED CURRENT	PK Control Rating	
	PWM FREQUENCY	2005	1.0-5.0 KHZ (Standard) 1.0-16.0 KHZ (Quiet)	2.5 KHZ	
	CUR RATE LIMIT	2006	0.001-10.000 SEC	0.004 SEC	
CUSTOM UNITS	DECIMAL PLACES	2101	0-5	5	
	VALUE AT SPEED	2102	0-65535 / 0-65535	00000/ 01000 RPM	
	UNITS OF MEASURE	2103	Selection of 9 Character Sets	-	
PROTECTION	OVERLOAD	2201	0-FOLDBACK, 1-FAULT	FOLDBACK	
	EXTERNAL TRIP	2202	0-OFF, 1- ON	OFF	
	LOCAL ENABLE INP	2203	0-OFF, 1- ON	OFF	
	FOLLOWING ERROR	2204	0-OFF, 1- ON	OFF	
	TORQUE PROVING	2205	0-OFF, 1- ON	OFF	
MISCELLANEOUS	RESTART AUTO/MAN	2301	0-MANUAL, 1-AUTOMATIC	MANUAL	
	RESTART FAULT/HR	2302	0-10	0	
	RESTART DELAY	2303	0-120 SECONDS	0 SEC	
	FACTORY SETTINGS	2304	0-NO, 1-YES	NO	
	HOMING SPEED	2305	0-MAX Speed	100 RPM	
	HOMING OFFSET	2306	0-65535 Encoder Counts	1024 CNTS	
SECURITY CONTROL	SECURITY STATE	2401	0-OFF 1-LOCAL SECURITY 2-SERIAL SECURITY 3-TOTAL SECURITY	OFF	
	ACCESS TIMEOUT	2402	0-600 SEC	0 SEC	
	ACCESS CODE	2403	0-9999	9999	
MOTOR DATA	MOTOR VOLTAGE	2501	150-999 VOLTS	Factory Set	
	MOTOR RATED AMPS	2502	0-999.9	Factory Set	
	MOTOR RATED SPD	2503	0-32767 RPM	1750 RPM	
	MOTOR RATED FREQ	2504	0-500.0 Hz	60.0 Hz	
	MOTOR MAG AMPS	2505	0-0.54 AMPS	CALC	
	ENCODER COUNTS	2506	0-65535 CNTS	1024 PPR	
	RESOLVER SPEEDS	2507	0 to 10	1 SPEED	
	CALC PRESETS	2508	0-NO, 1-YES	NO	

**Table A-3 Power Output Parameter Block Values Level 2** Continued

Level 2 Blocks - Continued					
Block Title	Parameter	P#	Adjustable Range	Factory	User Setting
BRAKE ADJUST	RESISTOR OHMS	2601	0-250.0 Ohms	Factory Set	
	RESISTOR WATTS	2602	0-360.00 Watts	Factory Set	
	DC BRAKE CURRENT	2603	0-100%	0	
PROCESS CONTROL	PROCESS FEEDBACK	2701	0- POTENTIOMETER 1- +/-10VOLTS 2- +/-5 VOLTS 3- 4 To 20mA 4- 5V EXB 5- 10V EXB 6- 4-20mA EXB 7- 3-15 PSI EXB 8- TACHOMETER EXB 9- NONE	NONE	
	PROCESS INVERSE	2702	0-OFF, 1- ON	OFF	
	SETPOINT SOURCE	2703	0- POTENTIOMETER 1- +/-10VOLTS 2- +/-5 VOLTS 3- 4 To 20mA 4- 5V EXB 5- 10V EXB 6- 4-20mA EXB 7- 3-15 PSI EXB 8- TACHOMETER EXB 9- NONE 10- SETPOINT CMD	SETPOINT CMD	
	SETPOINT COMMAND	2704	-100.0% to +100.0%	0.0 %	
	SET PT ADJ LIMIT	2705	0-100.0%	10.0 %	
	PROCESS ERR TOL	2706	1-100%	10 %	
	PROCESS PROP GAIN	2707	0-2000	0	
	PROCESS INT GAIN	2708	0-9.99 HZ	0.00 HZ	
	PROCESS DIFF GAIN	2709	0-1000	0	
	FOLLOW I:O RATIO	2710	(1-65535) : (1-20)	1:1	
FOLLOW I:O OUT	2711	1-65535 : 1-65535	1:1		
MASTER ENCODER	2712	50-65535	1024 PPR		

**Table A-3 Power Output Parameter Block Values Level 2** Continued

Level 2 Blocks - Continued					
Block Title	Parameter	P#	Adjustable Range	Factory	User Setting
COMMUNICATIONS	PROTOCOL	2801	0-RS-232 ASCII, 1-RS-485 ASCII, 2-RS-232 BBP, 3-RS-485 BBP	RS-232 BBP	
	BAUD RATE	2802	0-9600, 1-19.2KB, 2-38.4KB, 3-57.6KB, 4-115.2KB, 5-230.4KB, 6-460.8KB, 7-921.6KB	9600	
	DRIVE ADDRESS	2803	0 - 31	0	
AUTO-TUNING	<b>CALC PRESETS</b>	2508	0-NO, 1-YES	NO	
	<b>CMD OFFSET TRM</b> Measures and trims out offset voltage at Analog Input #2 (J1-4 & J1-5).	AU1	-	-	
	<b>CUR LOOP COMP</b> Measures current response while running motor at one half the rated motor current.	AU2	-	-	
	<b>STATOR R1</b> Measures stator resistance	AU3	-	-	
	<b>FLUX CUR SETTING</b> Sets the Motor Mag Amps.	AU4	-	-	
	<b>FEEDBACK TESTS</b> Checks the Master Encoder and Feedback Align values.	AU5	-	-	
	<b>SLIP FREQ TEST</b> Measures motor Slip Frequency during motor acceleration/deceleration at repeated intervals.	AU6	-	-	
	<b>SPD CNTRLR CALC</b> Measures the motor current to acceleration ratio during motor rotation. This procedure adjusts the Speed INT Gain and Speed PROP Gain parameters.	AU7	-	-	
LEVEL 1 BLOCK	Enters Level 1 Menu - See Table A-2.				
PRESS ENTER FOR PROGRAMMING EXIT	Exit programming mode and return to display mode.				



## Appendix B

---

## Remote Keypad Mounting Template

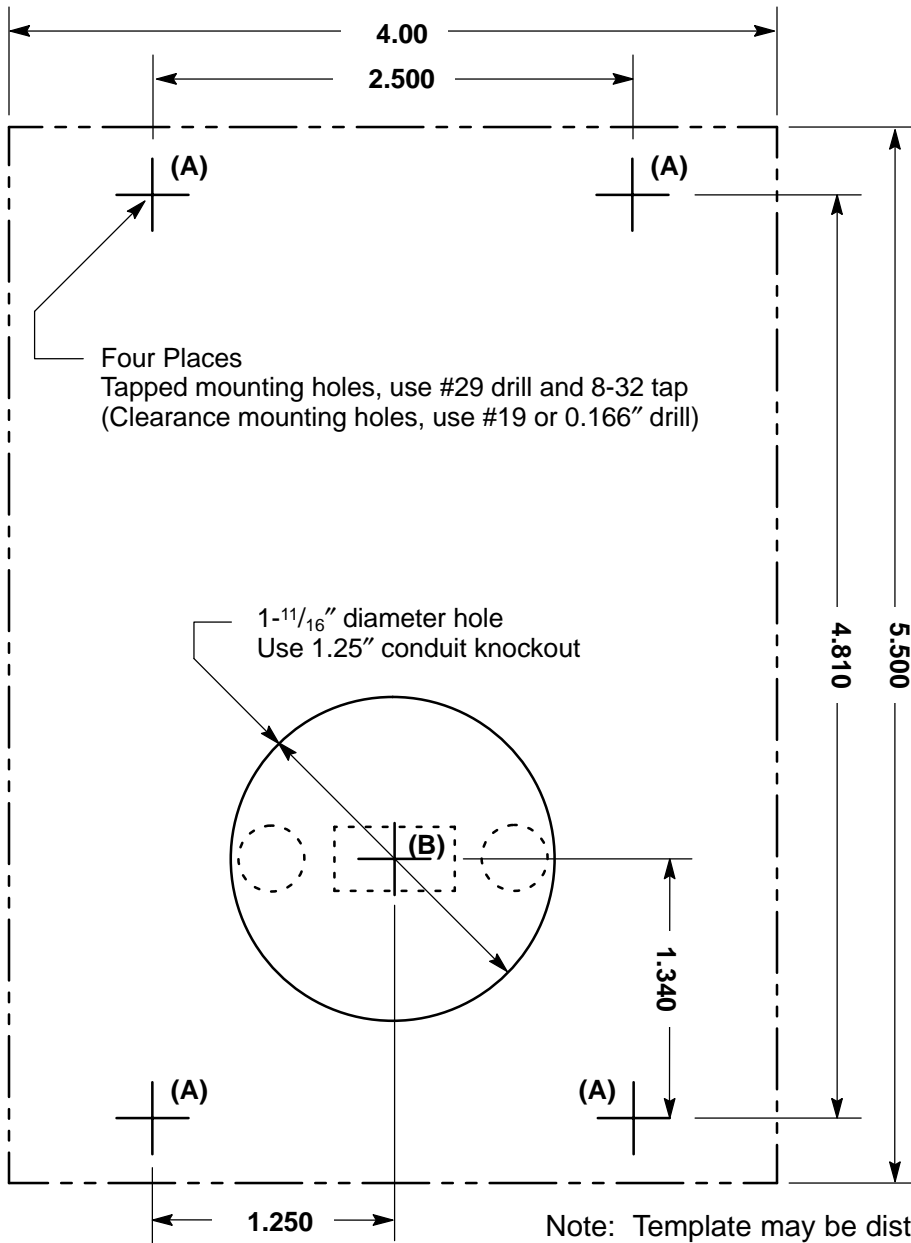

**BALDOR®**

**BALDOR ELECTRIC COMPANY  
P.O. Box 2400  
Ft. Smith, AR 72902-2400  
(479) 646-4711  
Fax (479) 648-5792**

**© 2003 Baldor Electric Company  
MN722**

**Printed in USA  
8/03 C&J1000**



**M41A04**

**Series 22H Line Regenerative Vector Control**

**MN722**