

ACURO®-DRIVE Absolute-Motorfeedback-Encoder



- For brushless servo motors
- Resolver size 15 compatible
- Through hollow shaft 8 mm
- 19 Bit Singleturn + 12 Bit Multiturn
- + 120°C operating temperature
- 10.000 rpm continuous operation
- Geared optical multiturn
- SSI or BiSS interface
- Sinewave 1 Vpp
- Bandwidth 500kHz

Contents

1	General	2
1.1	Application	2
1.2	Direct shaft coupling and stator coupling	2
1.3	The new Hengstler OptoAsic Technology	2
2	Electrical Data	3
2.1	General Design	3
2.2	Supply Voltage (SELV)	3
2.3	Intrinsic current consumption (w/o output current)	3
2.4	Resolution and Accuracy	3
2.5	Output signals	4
2.5.1	Incremental Signals A, B	4
2.5.2	Absolute Position-Information over SSI	5
2.5.3	Absolute Positions-Information over BiSS (Sensor-Mode)	5
2.5.4	Parameterization, diagnostic function and data storage (BiSS - Register Mode)	6
2.5.5	Recommended input circuit Standard SSI or BiSS to 10 MHz clock rate	11
2.5.6	Recommended input circuit with a incremental track 1 Vpp	11
2.6	CE-Compliance	12
2.6.1	EMV- Immunity	12
2.6.2	EMC Emission	12
2.7	Pinout PCB – Connector	12
2.8	Cable	12
3	Mechanical Data	13
3.1	Shaft variants	13
3.2	Max. shaft load / Bearing life expectancy	13
3.3	Max . speed	13
3.4	Starting torque	13
3.5	Moment of inertia	13
3.6	IP - Protection	13
3.7	Operating temperature range	14
3.8	Storage temperature range	14
3.9	Humidity	14
3.10	Vibration resistance	14
3.11	Shock resistance	14
3.12	Materials	14
3.13	Spring tether	14
3.14	Dimensioned drawings	15
3.14.1	Through hollow shaft	15
3.14.2	Hub shaft	15
4	Ordering data	16

ACURO[®]-DRIVE Absolute-Motorfeedback-Encoder**1 General****1.1 Application**

The **AD36** is an absolute encoder with a true geared Multiturn, optical sensing technology and 36 mm diameter. Unique is the through hollow shaft which enables an assembly that is compatible with resolver size 15. The mechanical design consists of two ball bearings and a flexible torque support. The AD36 complements the *ACURO[®]-DRIVE* series and is appropriate for use within BLDC servo motors with small frame sizes.

Fully digital control loop

The new and completely digital OptoAsic technology enables the transition to a truly digital drive system. The conventional absolute encoders still have analog sine wave signals for the feedback of speed and position data. The AD36, however, provides fully digital position data up to 19 Bit (Singleturn) and 12 Bit (Multiturn) over the *BiSS* interface with a variable clock rate up to 10 MHz. *BiSS* is the only open high speed bidirectional sensor interface available on the market.

Backwards Compatible to SSI + sincos

For a smooth design in process in existing environments the **AD36** provides backwards compatibility through 2048 periods /rev. sinewave signals (1Vpp) combined with a standard SSI interface. This enables qualification and testing of the encoder with most existing drives.

More Safety through redundancy of code, self monitoring, CRC and geared multiturn

For redundancy purpose the sinewave output can be used in parallel with the *BiSS* absolute data channel. A permanent code plausibility check detects any wrong position information caused by any reason. The encoder communicates detected errors via status bits to the drive. The AD36 operates from -15 °C up to 120 °C . The encoder monitors its internal temperature in the range $-40\text{ °C} \dots +140\text{ °C}$. The temperature value is transmitted in 8 bit resolution via multicycle bits. The user can define lower and upper temperature limits. The AD36 sends warnings if the customer defined limits are exceeded. The multiturn mechanism supports safety through use of true geared optical technology, that is not affected by strong magnetic fields.

1.2 Direct shaft coupling and stator coupling

The AD36 comes with an 8mm hollowshaft, that can be mounted with a jam nut or central shaft screw like a resolver. The screw holes of the spring tether are on the same bolt circle as those for a size 15 resolver. This enables an easy upgrade from resolver feedback to multiturn absolute technology without any mechanical modifications.

1.3 The new Hengstler OptoAsic Technology

The central element of the *ACURO[®]-DRIVE* is the latest technology Hengstler OptoAsic, that contains almost all of the electronics. The most outstanding benefits are:

- High signal quality through integrated control and error compensation.
- Unequaled bandwidth of 500 kHz of sinewave signals at full signal quality.
- Highest EMC immunity through signal paths in the μm range.
- Excellent reliability through reduction of parts and integrated diagnosis system.
- Aging compensation through integrated light regulation of the LED.
- Integrated monitoring of:
 - Pollution
 - Disk damage
 - End of LED - live
 - Temperature

ACURO®-DRIVE Absolute-Motorfeedback-Encoder**2 Electrical Data****2.1 General Design**

Protection Degree III

Pollution Degree 2

Over voltage Category II

according DIN EN 61010 part 1 (03.94)/ EN 61010-1/A2 (05.96) (VDE 0411)

2.2 Supply Voltage (SELV)

DC 5 V -5%/ +10%

DC 7...30 V

2.3 Intrinsic current consumption (w/o output current)Singleturn: at DC 5 V \leq 45 mAMultiturn: at DC 5 V \leq 85 mA**2.4 Resolution and Accuracy**

Incremental Signals (A, B)

2048 Periods / Revolution

Absolute accuracy $\leq \pm 0,01^{\circ}_{\text{mechanical}}$ ($\pm 36''$)Repeatability $\leq \pm 0,002^{\circ}_{\text{mechanical}}$ ($\pm 7,2''$)

ACURO®-DRIVE Absolute-Motorfeedback-Encoder

2.5 Output signals

2.5.1 Incremental Signals A, B

Track A leads B by 90° at rotation and view on shaft end.

$$A = U_M + \hat{U}_A \sin(Z\varphi_{\text{mech.}})$$

$$A^* = U_M - \hat{U}_A \sin(Z\varphi_{\text{mech.}})$$

$$B = U_M - \hat{U}_B \cos(Z\varphi_{\text{mech.}})$$

$$B^* = U_M + \hat{U}_B \cos(Z\varphi_{\text{mech.}})$$

z: No. Of signal periods (2048)

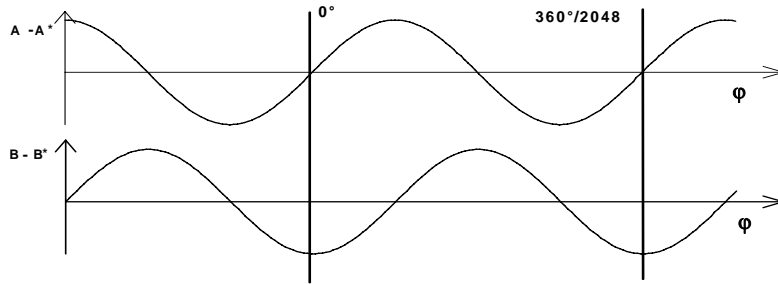

Amplitudes:^{1) 2)}

$$\hat{u}_{(A-A^*; B-B^*)} = 0,5V - 25\% / + 20\%$$

(f ≤ 1kHz)

$$\hat{u}_{(A-A^*; B-B^*)} = 0,35V \dots 0,6V$$

(f > 1kHz)

- Limiting frequency

$$f_{gr} = 500 \text{ kHz}$$

- Amplitudes difference ¹⁾

$$\hat{u}_{(A-A^*)} = \hat{u}_{(B-B^*)} \pm 10 \%$$

- Degree of modulation (mech.) ⁴⁾

$$m \leq 0,1$$

- Offset

$$|U_{off (A-A^*; B-B^*)}| < 0,1 \hat{u}_{(A-A^*; B-B^*)}$$

- Phase A to B ⁶⁾

$$\varphi = 90^\circ \pm 3^\circ$$

- Harmonic distortion ³⁾

$$k < 2 \% \text{ (typ. 1 \%)}$$

- DC Offset ⁵⁾

$$U_M = 2,5 \text{ V} \pm 20 \%$$

- Signal

¹⁾ : measured with 120 Ω termination resistor at encoder output

²⁾ : at f = 1 kHz (corresponds to 30 U/min)

$$^3) k = \frac{\sqrt{U1^2 + U2^2 + \dots + Un^2}}{\sqrt{U0^2 + U1^2 + \dots + Un^2}}$$

U0: Basic Signal , U1 ... Un : harmonics

$$^4) m = \frac{\Delta u}{u}$$

⁵⁾ U_M same for A and A* and for B and B* signals.

⁶⁾ Average

ACURO®-DRIVE Absolute-Motorfeedback-Encoder

2.5.2 Absolute Position-Information over SSI

Resolution standard SSI (25 data bits)

Singleturn	17 Bit
Multiturn	12 Bit

Optional: Resolution SSI with extendable data length (> 25 data bits)

Singleturn	max 19 Bit
Multiturn	12 Bit
*Singleturn in 25-Bit MT-Model	programmable up to 19 Bit

Transmission via SSI bidirectional and synchronous

No. of wires and direction	4 unidirectional (2 for clock and 2 for data)
Driver according to	RS422
Transmission speed	70kHz –2 MHz according to SSI - definition

Data format

MSB first	Monoflop – Timeout $10\mu s \leq t_m \leq 14\mu s$
-----------	--

2.5.3 Absolute Position-Information over BiSS (Sensor-Mode)

Digital coded absolute information

Resolution Singleturn w/IPO	up to 19 Bit
Resolution Multiturn	12 Bit

Transmission via BiSS - bidirectional und synchronous

Signals	Clock unidirectional (from master to encoder) Data unidirectional (from encoder to master)
Driver according to	RS422
No. of wires and direction	4 unidirectional (2 for clock and 2 for data)
Transmission speed	70 kHz – 10 MHz
Transmission security	1 Start Bit, 1 Stop Bit, 6 Bit CRC
Multicycle data (MCD)	8 Bit Sensor temperature (s. Documentation www.biss-interface.com/files/BiSS_b1ds.pdf)
Timeout Sens	12 μ sec
Timeout Reg	51 μ sec
Delay for Calculation	≤ 14 Bit ST resolution 0 μ s ≥ 15 Bit ST resolution 5 μ s

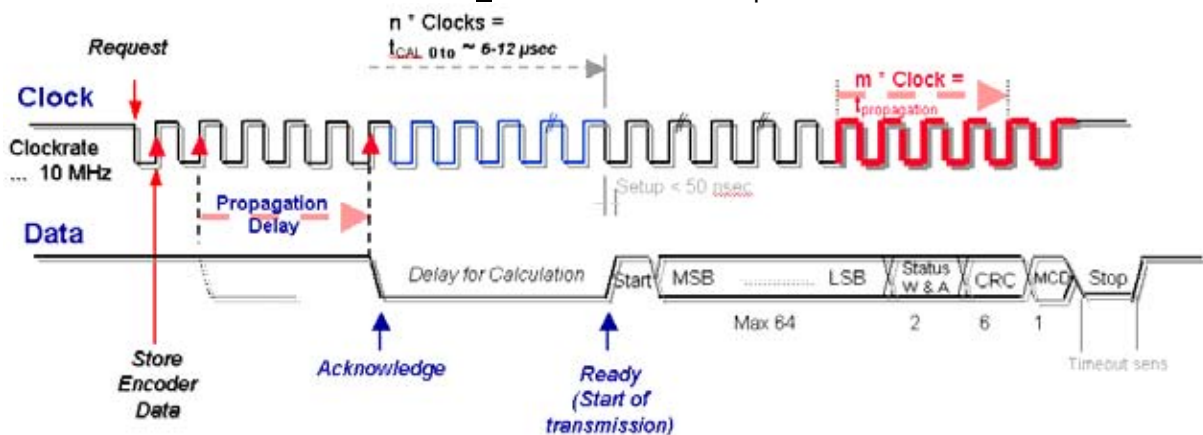

ACURO®-DRIVE Absolute-Motorfeedback-Encoder

2.5.4 Parametrization, diagnostic function and data storage (BiSS - Register Mode)

Transmission over BiSS: Bidirectional and synchronous in PWM format.

Several encoder parameters are set here. In addition to detailed information for warning and alarm also the latest encoder temperature can be read. For storage of data a memory of 128 byte is available by default. More memory space can be provided on request.

Write register

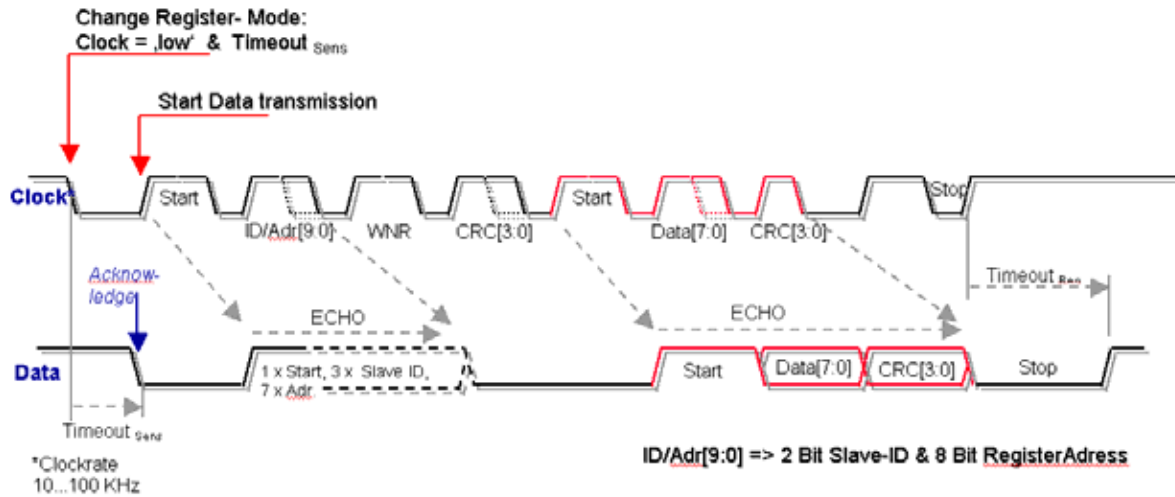

Read register

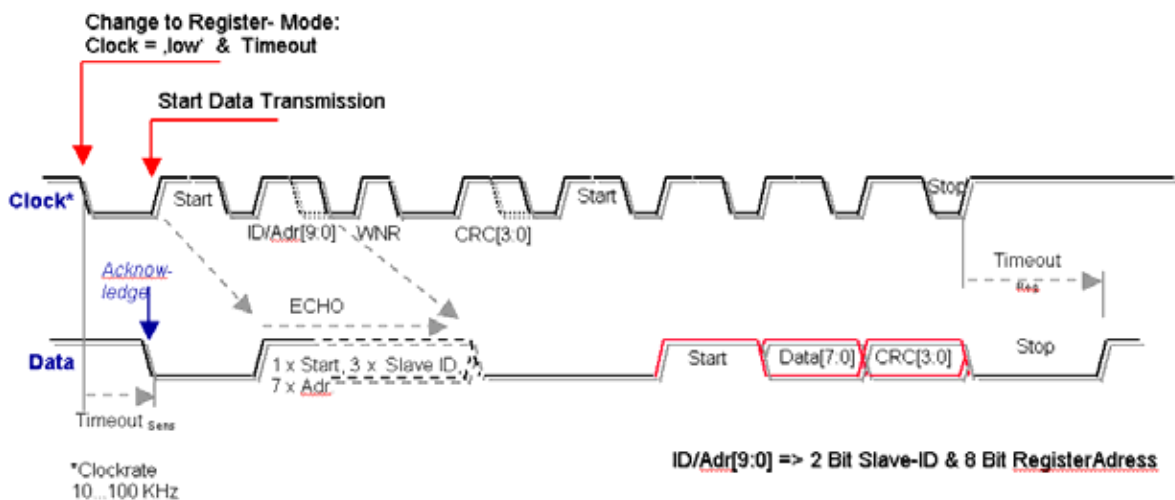

Address room

Address	R/W-Protection			Bank 0	1	
0x00 ... 0x09	high security	RAM configuration data	128 Byte	configuration data	OEM	
0x0A ... 0x0F						
0x010 ... 0x2F	high security					
0x30 ... 0x31						
0x32 0x33 ... 0x5F	low security	encoder identification		identification		OEM
0x60 ... 0x69		position-and status data				
0x6A ... 0x77						
0x78 ... 0x7F	low security	ROM BiSS-identification		EEPROM BiSS-identification OEM		
0x80 ... 0xFE				OEM		
0xFF		Bank Select		128 Byte		

	Technical Datasheet AD36	HENGSTLER
ACURO®-DRIVE Absolute-Motorfeedback-Encoder		

Register assignment (Blank 0)

		high security		
		low security		
ADR	Content	ADR	Content	
0x00		X	0x30	
0x01		X	0x31	
0x02		X	0x32	
0x03		X	0x33 ... Encoder identification	
0x04		X		
0x05		X		
0x06		X		
0x07		X		
0x08		X		
0x09		X		
0x0A	Preset-Multiturn Part 1			0x5F
0x0B	Preset-Multiturn Part 2			
0x0C	Preset-Multiturn Part 3			
0x0D	Preset-SingleturnPart 1			
0x0E	Preset-SingleturnPart 2 + Interpolator Part 1			
0x0F	Preset-Interpolator Part 2			
0x10		X	0x60 Instruction register/ Status register	
0x11		X	0x61 Position data register (Multiturn)	
0x12		X	0x62 Position data register (Multiturn)	
0x13		X	0x63 Position data register (Multiturn)	
0x14		X	0x64 Position data register (Singleturn)	
0x15		X	0x65 Position data register (Singleturn, Interpolator)	
0x16		X	0x66 Position data register (Singleturn)	
0x17		X	0x67 Temperature value	
0x18		X	0x68 Failure register	
0x19		X	0x69 Version register	
0x1A		X	0x6A	
0x1B		X	...	
0x1C		X	0x78	
...		X	... BiSS identification	
0x2D		X	0x7F	
			...	
			0x80 External EEPROM data	
			...	
0x2E		X	0xFE	
0x2F		X	0xFF Bank-Select	

Address	Bits	Value	ASCII	Meaning		
0x78	7:0	0x41	A	Product identification		
0x79	7:0	0x43	C	ACURO		
0x7A	7:0	0x3A				
0x7B	7:5	0b000		no Multiturn		
		0b001		12 Bit Multiturn		
		0b010		16 Bit Multiturn		
		0b011		20 Bit Multiturn		
		0b100		24 Bit Multiturn		
		4:0	0b01001	0b01001		9 Bit Singleturn
				0b01010		10 Bit Singleturn
				0b01011		11 Bit Singleturn
				0b01100		12 Bit Singleturn
				0b01101		13 Bit Singleturn
				0b01110		14 Bit Singleturn
				0b01111		15 Bit Singleturn
				0b10000		16 Bit Singleturn
		0b10001		17 Bit Singleturn		
		0b10010		18 Bit Singleturn		
		0b10011		19 Bit Singleturn		
0b10100		20 Bit Singleturn				
0b10101		21 Bit Singleturn				
0b10110		22 Bit Singleturn				
0b10111		23 Bit Singleturn				
0b11000		24 Bit Singleturn				
0x7C	7:0	0x00		free		
0x7D	7:0	0x00		free		
0x7E	7:0	0x48	H	producer identification		
0x7F	7:0	0x45	E	Hengstler		

Example for BiSS identification of absolute encoders:

Singleturn 19 Bit:
41 43 3A 13 00 00 48 45

Multiturn 12 Bit MT + 17 Bit ST:
41 43 3A 31 00 00 48 45

ACURO®-DRIVE Absolute-Motorfeedback-Encoder**Function Preset:**

A preset function is set if the value 0x02h is written to the register address 0x60h. With this action preset value is set and the corresponding offset value is saved to EPROM.

Initial situation: preset value = 0

Read temperature value:

In the register 0x67h the temperature is stored and updated. Reading the register a 8 Bit absolute temperature value is received.

Diagnostic function:

If programmable limits are exceeded or under run this is indicated over warning and alarm bits.

Read error status:

If the alarm bit or the warning bit is set within the protocol "read position data" (SSI or BiSS) the cause of the error can be determined over the register 0x68h. Reading this register an 8 bit value is received.

Meaning:

Bit 0 = LED current out of control range

Bit 1 = External Multiturn Error

Bit 2 = Position Code Error (Single Step Error)

Bit 3 = Failure configuration interface

Bit 4 = Position data not valid

Bit 5 = Serial interface failure

Bit 6 = External failure over NERR

Bit 7 = Temperature out of defined range

Reaction on error message

Error messages can be acknowledged in different ways. The message can be displayed one time in the protocol. Alternatively the message can be transmitted until it has been acknowledged via command. The way the error message is acknowledged is set in the register 0x1B Bit 2 and is factory configured according to the OEM customer's preference.

Function in detail:**Error message one time (monostable):**

If one of the error conditions occurs, the alarm bit will be set (logical "1" in the protocol telegram).

Reading the position data will reset the alarm bit. Depending on the further presence of the error condition the alarm bit will set again to "1" or stay on "0" in the following cycle.

Error message static (bistable):

If one of the error conditions occurs, the alarm bit will be set (logical "1" in the protocol telegram).

Independent on the further presence of the error condition the alarm bit will stay on "1" until it is reset through reading of the error register (Error register 0x68).

Error conditions

LED current out of defined range

This condition can be caused by critical conditions with respect to:

- Pollution
- Condensation
- Over temperature
- Ageing of LED

Code-Plausibility check error

This can be caused by:

- Disk pollution or disk damage
- mechanical overload

Temperature value out of range

- Warning if user defined temperature range is exceeded

Reading and writing of the freely accessible memory

From the register address 0x80h to 0xFEh (0xFF is reserved for bank select register) 127 byte can be used in the bank "0" and 255 byte can be used in the bank "1".

The bank select is activated via the register 0xFFh. If bank "0" is required than the value 0x00h has to be written in the address 0xFFh and if bank "1" is required then 0x01h has to be written in the address 0xFFh. With "read register" and "write register" memory access is performed.

Memory allocation (Memory Map)

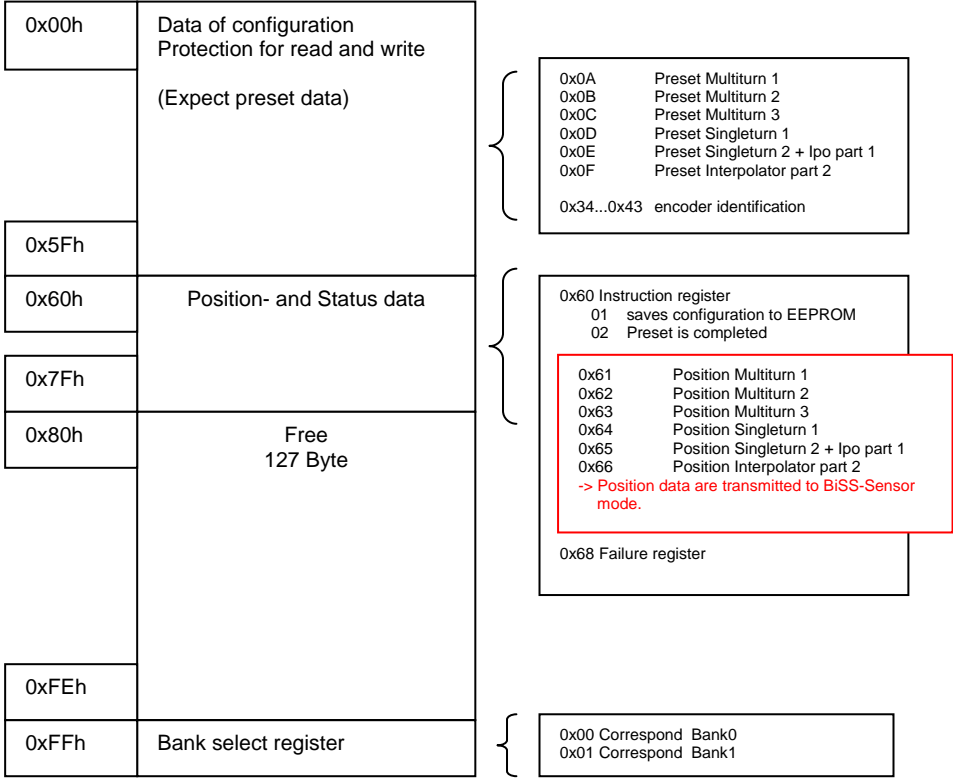

ACURO®-DRIVE Absolute-Motorfeedback-Encoder

Encoder Identification (Manufacturing data, Resolution)

Reg. Addr.	Description	Length	Format	1.	2.	3.	4.
Reg. 0x34	Serial number	4 Byte	Ser.-No. BCD format	SS	SS	SS	LL
Reg. 0x38	Date of manufacture	4 Byte	Date BCD format	DD	MM	YY	YY
Reg. 0x3C	Article code	4 Byte	Article code BCD format	XX	XX	XX	0
Reg. 0x40	MT-Resolution	1 Byte	MT BCD format (0...12-Bit)	12			
Reg. 0x41	ST-Resolution	1 Byte	ST BCD format (9...13-Bit)	14			
Reg. 0x42	IPO-Resolution	1 Byte	IPO BCD format (0...11-Bit)	3			
Reg. 0x43	SinCos Periods	2 Byte	SinCos BCD format	20	48		

2.5.5 Recommended input circuit Standard SSI or BiSS to 10 MHz clock rate

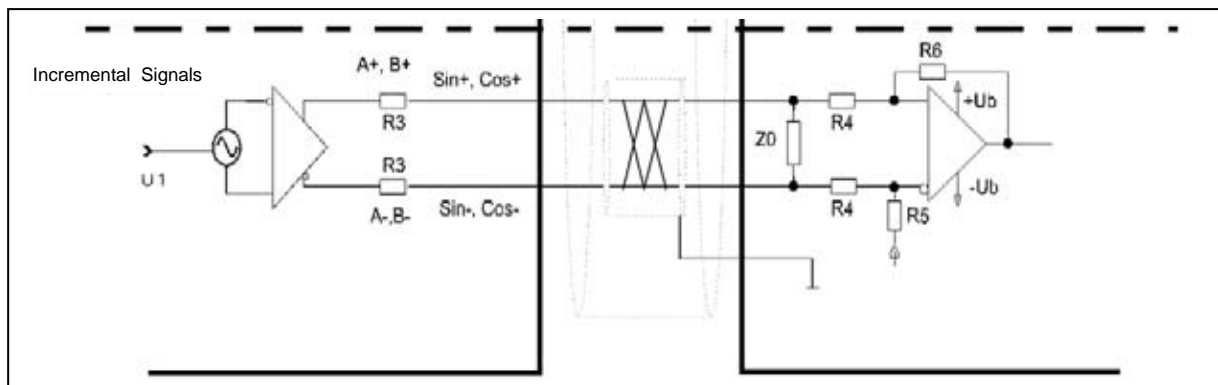
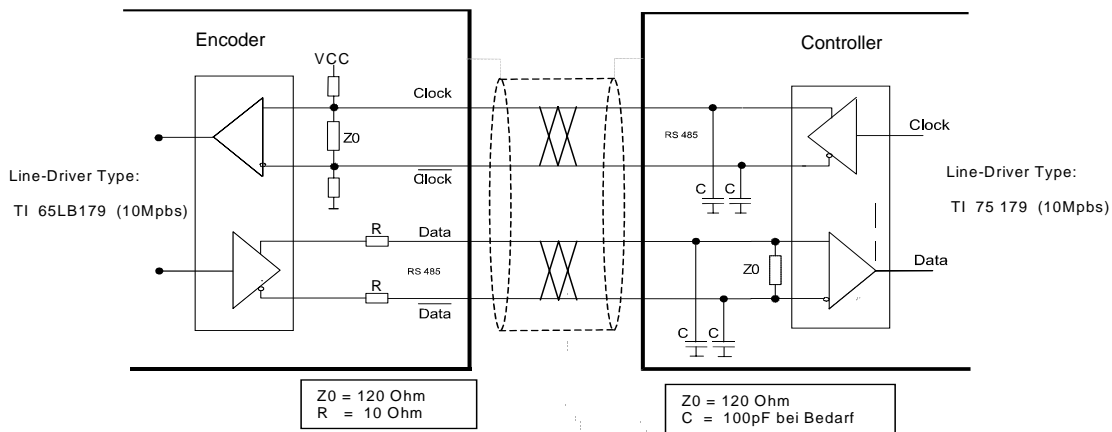

2.5.6 Recommended input circuit with incremental track 1 Vpp

Dimensions:

R1 = 91 Ω , R2 = 100 Ω , R3 = 10 Ω , R4 = 10kΩ , R5 = R4* , Z0 = 120 Ω

C1 = 1nF

U1 = 2,5 V ± 0,5V (relating to supply voltage).

*1) Alternative mounting for high transmission rates (> 2MHz) and for operating with several encoders simultaneously (i.e. shared clock, split data line).

2.6 CE-Compliance

2.6.1 EMC- Immunity

ENV 50140	Class 3, 10 V/m
EN 61000-4-2	Class 4, 15 kV (air discharge), 8kV (contact discharge)
ENV 50141	Class 3, 10 V
ENV 61000-4-4	Class 4, 4000 V *

* Remark: *Direct coupling on the power supply needs limitation of the distortion pulses to max. 1000V*

Test standard: EN 50082-2

Cover:	
ENV 50140	Electromagnetic HF-Field, amplitude modulated
ENV 50140	Electromagnetic HF-Field, pulse modulated
EN 61000-4-2	Electrostatic Discharge (ESD)

Terminations:	
ENV 50141	High frequency, non symmetric, amplitude modulated
EN 61000-4-4	Transients (Burst)
	Mains input and outputs
	Data-, measuring-, control lines

2.6.2 EMC Emission

Class B

Test standard: EN 50081-2

Cover:	
EN 55011	Radio frequency emission

2.7 Pinout PCB – Connector

							
Row b	5 or 7-30 V (U _B) gr/pk	Clock wt	B- rd	0V (U_N) wt/gn	A- ye	Data bk	
Row a	Data/ vio	A+ gn	0V Sens bn/gn	B+ bl	Clock/ bn	5 V Sens rd/bl	
PIN	1	2	3	4	5	6	

Hint:
 5 V (U_B) → 5 V Sens
 0 V (U_N) → 0 V Sens

Connection on encoder side over
 12-pin PCB connector,
 Manufacturer Berg, Type: Minitek.

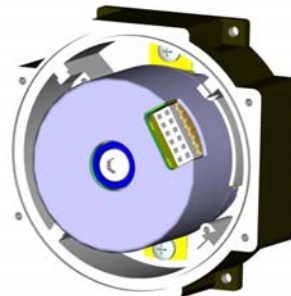

2.8 Cable

SSI: max. cable length	100 m (70KHz...2 MHz)
BiSS (CAT5 cable): max. cable length	Cable capacity ≤ 100 pF/m 100 m (0...10 MHz)

ACURO®-DRIVE Absolute-Motorfeedback-Encoder**3 Mechanical Data****3.1 Shaft variants**

8 mm – through hollow shaft

8 mm –hub shaft

3.2 Max. shaft load / Bearing life expectancyaxial ≤ 5 Nradial ≤ 10 N

Above values are the max. worst case forces to the encoder bearings through the flexible torque support

(Fixing point of torque support is 10mm towards the encoder referring the diameter 9,25 mm)

Bearing Live at constant speed of 8.000 1/min and above mentioned loads > 20.000 h.

3.3 Max . speedContinuous 12.000 min⁻¹Short term 15.000 min⁻¹ ST*The peak max. speed considers eventual oscillations in the speed loop and may occur only for a short time (max. 1 second).***3.4 Starting torque** ≤ 1 Ncm**3.5 Moment of inertia**2,5 x 10⁻⁶ kgm²*Inclusive central shaft screw***3.6 IP - Protection**

IP40

Mounted on motor with cable and cover

Test standard: IEC 529, EN 60529 resp. DIN VDE 0470 T1 (11.92) and DIN 40053 T5 (7.80)

ACURO®-DRIVE Absolute-Motorfeedback-Encoder**3.7 Operating temperature range**

Environmental air of encoder: -15°C ... +120°C
 Motor shaft at encoder connection point: -15°C ... 160°C
 Connection points of torque support and motor: -15°C ... 140°C

3.8 Storage temperature range

-20°C ... +85°C (due to packaging)

3.9 Humidity

Humidity F (KUF annual average 75% rel. humidity; non condensing)

Test standard: IEC 68 part 2-38 „temperature, humidity, cycle“ (04.79)
 Test condition adjusted to humidity F (DIN 4040)

3.10 Vibration resistance

100 m/s² (10 ... 2000 Hz)

Test standard: DIN EN 60068-2-6 / 05.96
 Test Fc: Vibration, sinusoidal

3.11 Shock resistance

1000 m/s² (6 ms)

Test standard: DIN EN 60068-2-27 / 03.95
 Test Ea and guideline: shock

3.12 Materials

Flange: Aluminum
 Shaft: Stainless steel
 Cover: Aluminum
 Mass: Singleturn app. 80 g
 Multiturn app.130 g

3.13 Spring tether

Tolerance axial ± 0,5 mm
 Tolerance radial ± 0,05 mm
 Resonance frequency > 2 kHz

ACURO®-DRIVE Absolute-Motorfeedback-Encoder

3.14 Dimensioned drawings

3.14.1 Through hollow shaft

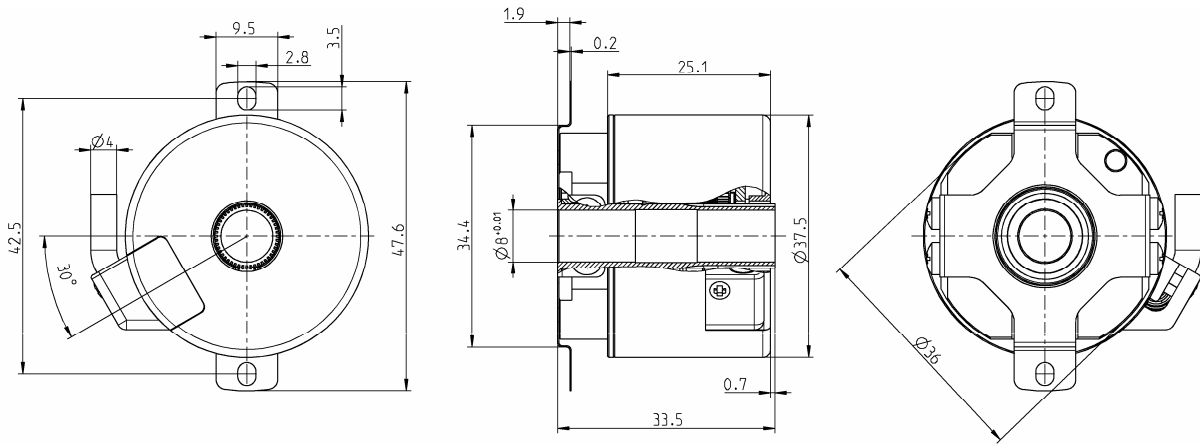

3.14.2 Hub shaft

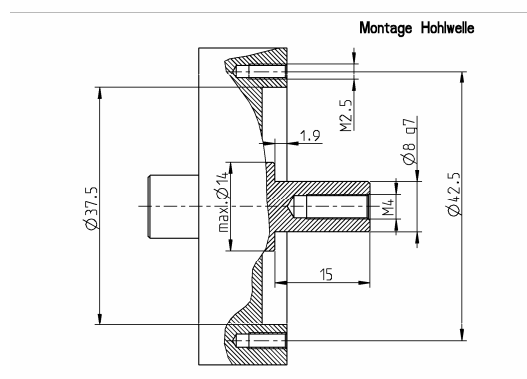
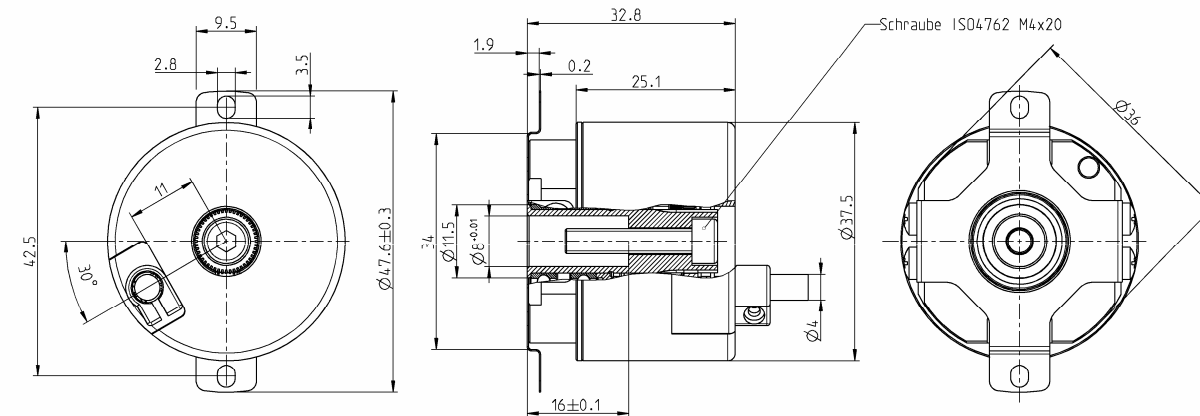

4 Ordering data

Type	Resolution	Supply voltage	Flange, Protection, Shaft	Interface	Connection
AD 36	0012 12 Bit ST 0013 13 Bit ST 0014 14 Bit ST 0017 17 Bit ST 0019 19 Bit ST (BiSS) 1213 12 Bit MT +13 Bit ST 1217 12 Bit MT +17 Bit ST 1219 12 Bit MT +19 Bit ST (BiSS)	A DC 5V E DC 7-30V	F.OC Spring tether, IP40, 8mm through hollow shaft F.OR Spring tether, IP40, 8mm hub shaft	SC SSI Gray + 1Vss BI BiSS (1 Vss redundant optional)	O PCB-connector, 12-pin B Cable radial, 0,5 m

HENGSTLER

HENGSTLER GmbH
 Uhlandstr. 49
 78554 Aldingen / Germany
 Tel. +49 (0) 7424-89 0
 Fax +49 (0) 7424-89 500
 E-Mail: info@hengstler.com
www.hengstler.com

